

1Mx32 FLASH MODULE

DESCRIPTION

The ED17F331MC and ED17F2331MC are organized as one and two banks of 1Mx32 respectively. The modules are based on AMDs AM29F080 - 1Mx8 Flash device in TSOP packages which are mounted on an FR4 substrate.

Both modules offer access times between 80 and 150ns allowing for operation of high-speed microprocessors without wait states.

FEATURES

- 1Mx32 and 2x1Mx32 Densities
- Based on AMD - AM29F080 Flash Device
- Fast Read Access Time - 80ns
- 5V-Only Reprogramming
- Sector Erase Architecture
 - Uniform sectors of 64 Kbytes each
 - Any combination of sectors can be erased
 - Also supports full chip erase
- Sector Protection
 - Hardware method that disables any combination of sectors from write or erase operations
- Embedded Erase Algorithms
 - Automatically preprograms and erases the chip or any combination of sectors
- Embedded Program Algorithms
 - Automatically programs and verifies data at specified address
- Data Polling and Toggle Bit feature for detection of program or erase cycle completion
- Low Power Dissipation
 - 60mA per Device Active Current
 - 10µA per Device CMOS Standby Current
 - Typical Endurance >100,000 Cycles
- Single 5V ±10% Supply
- CMOS and TTL Compatible Inputs and Outputs
- Commercial and Industrial Temperature Range
- Package
 - 80 Pin SIMM (JEDEC)

FIG. 1

BLOCK DIAGRAMS

ED17F331MC-BNC: 1Mx32 80 PIN SIMM

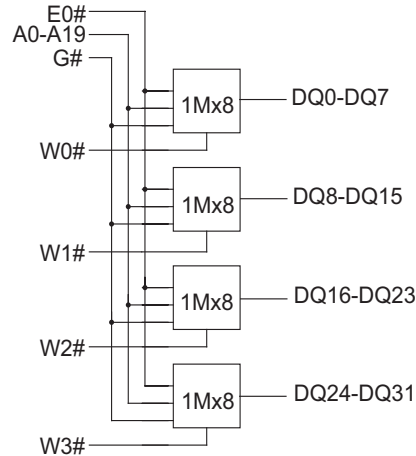

ED17F2331MC-BNC: 2x1Mx32 80 PIN

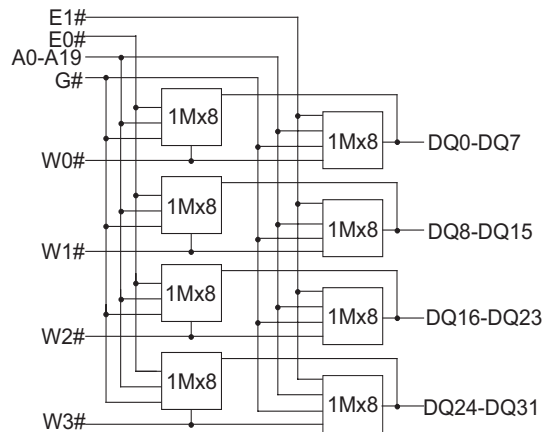



CAPACITANCE

(f=1.0MHz, VIN = VCC or VSS)

		1Meg	2x1Meg	
Parameter	Sym	Max	Max	Unit
Address Lines	CA	35	70	pF
Data lines	CDQ	15	30	pF
Chip & Write Enable Lines	CC	15	30	pF
Output Enable lines	CG	35	70	pF

PIN CONFIGURATIONS

Pin #	Pin Name	Pin #	Pin Name	Pin #	Pin Name	Pin #	Pin Name
1	VSS	21	*	41	A11	61	DQ9
2	VCC	22	*	42	A10	62	DQ8
3	NC	23	*	43	A9	63	DQ7
4	G#	24	*	44	A8	64	DQ6
5	W0#	25	VSS	45	A7	65	DQ5
6	W1#	26	DQ29	46	A6	66	DQ4
7	NC	27	DQ30	47	A5	67	DQ3
8	DQ16	28	DQ31	48	A4	68	DQ2
9	DQ17	29	W2#	49	A3	69	DQ1
10	DQ18	30	NC	50	A2	70	DQ0
11	DQ19	31	NC	51	A1	71	NC
12	DQ20	32	NC	52	AO	72	VCC
13	DQ21	33	A19	53	W3#	73	PD1
14	DQ22	34	A18	54	VSS	74	PD2
15	DQ23	35	A17	55	DQ15	75	PD3
16	DQ24	36	A16	56	DQ14	76	PD4
17	DQ25	37	A15	57	DQ13	77	PD5
18	DQ26	38	A14	58	DQ12	78	PD6
19	DQ27	39	A13	59	DQ11	79	PD7
20	DQ28	40	A12	60	DQ10	80	VSS

*TBD

SIMM Density		
Pin	1Meg	2x1Meg
21	NC	NC
22	NC	NC
23	NC	E1#
24	E0#	E0#

Presence Detect PIN Out		
Pin	1Meg	2x1Meg
PD1	NC	VSS
PD2	VSS	VSS
PD3	NC	NC
PD4	VSS	VSS

A0-A19 Address input
 E0#,E1# Chip Enable
 W0#-W3# Write Enable
 G# Output Enable
 DQ0-DQ31 Data Input/Output
 Pd Presence Detect
 VCC Power 5V±10%
 VSS Ground
 NC No Connect

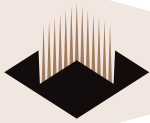

ORDERING INFORMATION

Part Number	Speed (ns)	Package
EDI7F331MC80BNC	80	346
EDI7F331MC90BNC	90	346
EDI7F331MC100BNC	100	346
EDI7F331MC120BNC	120	346
EDI7F331MC150BNC	150	346

Note: To order an Industrial grade product substitute the letter C in the Suffix with the letter I.

PACKAGE NO. 346: 80 PIN SIMM

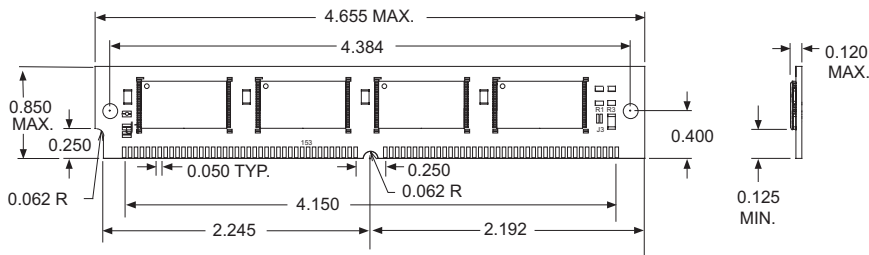

ORDERING INFORMATION

Part Number	Speed (ns)	Package
EDI7F2331MC80BNC	80	361
EDI7F2331MC90BNC	90	361
EDI7F2331MC100BNC	100	361
EDI7F2331MC120BNC	120	361
EDI7F2331MC150BNC	150	361

Note: To order an Industrial grade product substitute the letter C in the Suffix with the letter I.

PACKAGE NO. 361: 80 PIN SIMM (JEDEC)

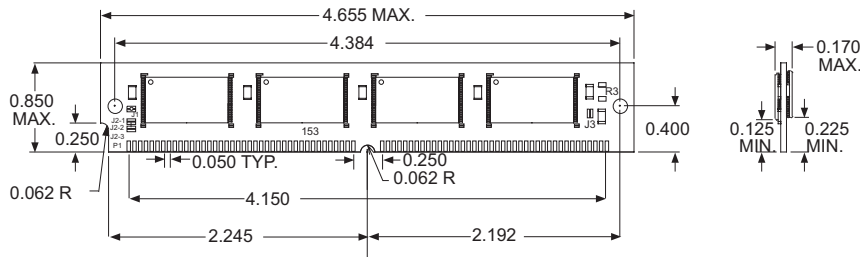

ALL DIMENSIONS ARE IN INCHES