

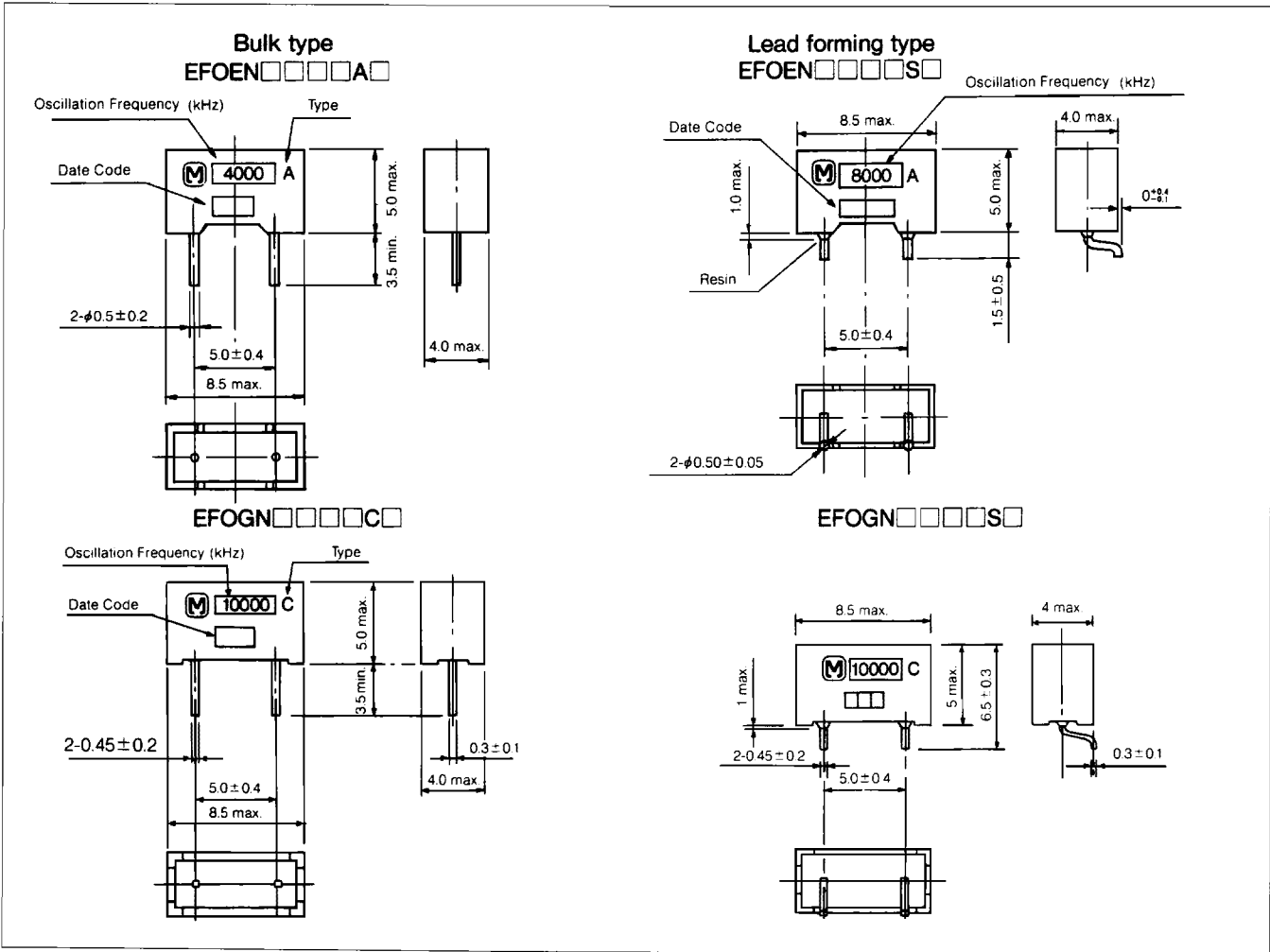

Dimensions in mm (not to scale)

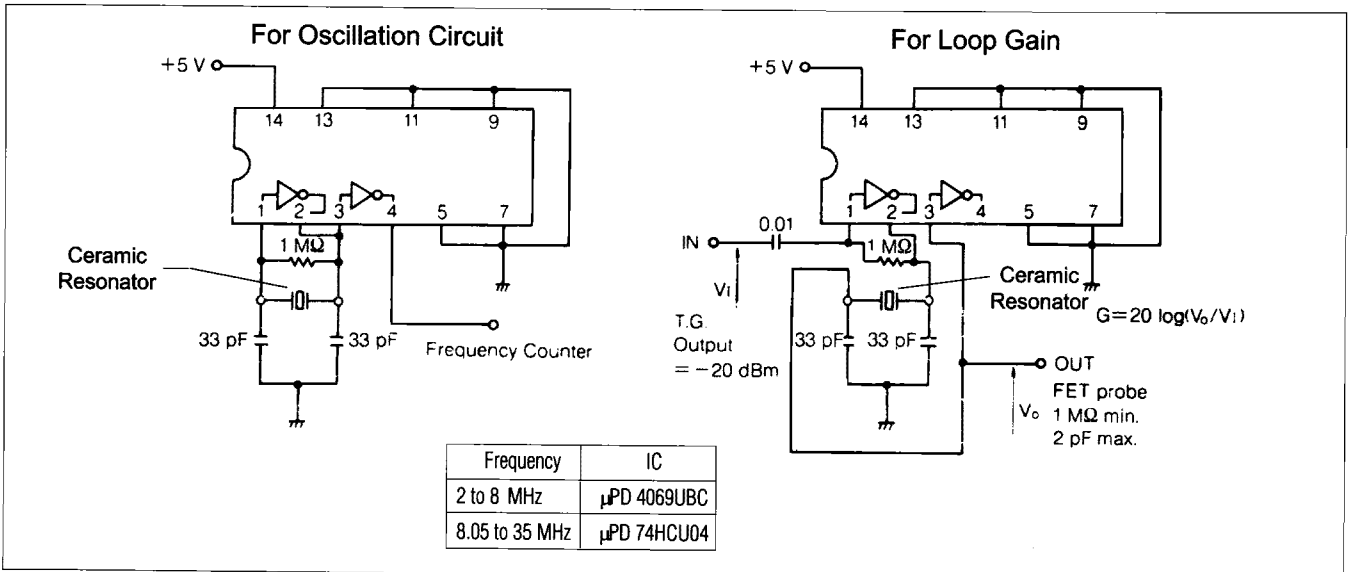

Test Circuit Diagram



**Typical Characteristics (EFOGN4004A4)**

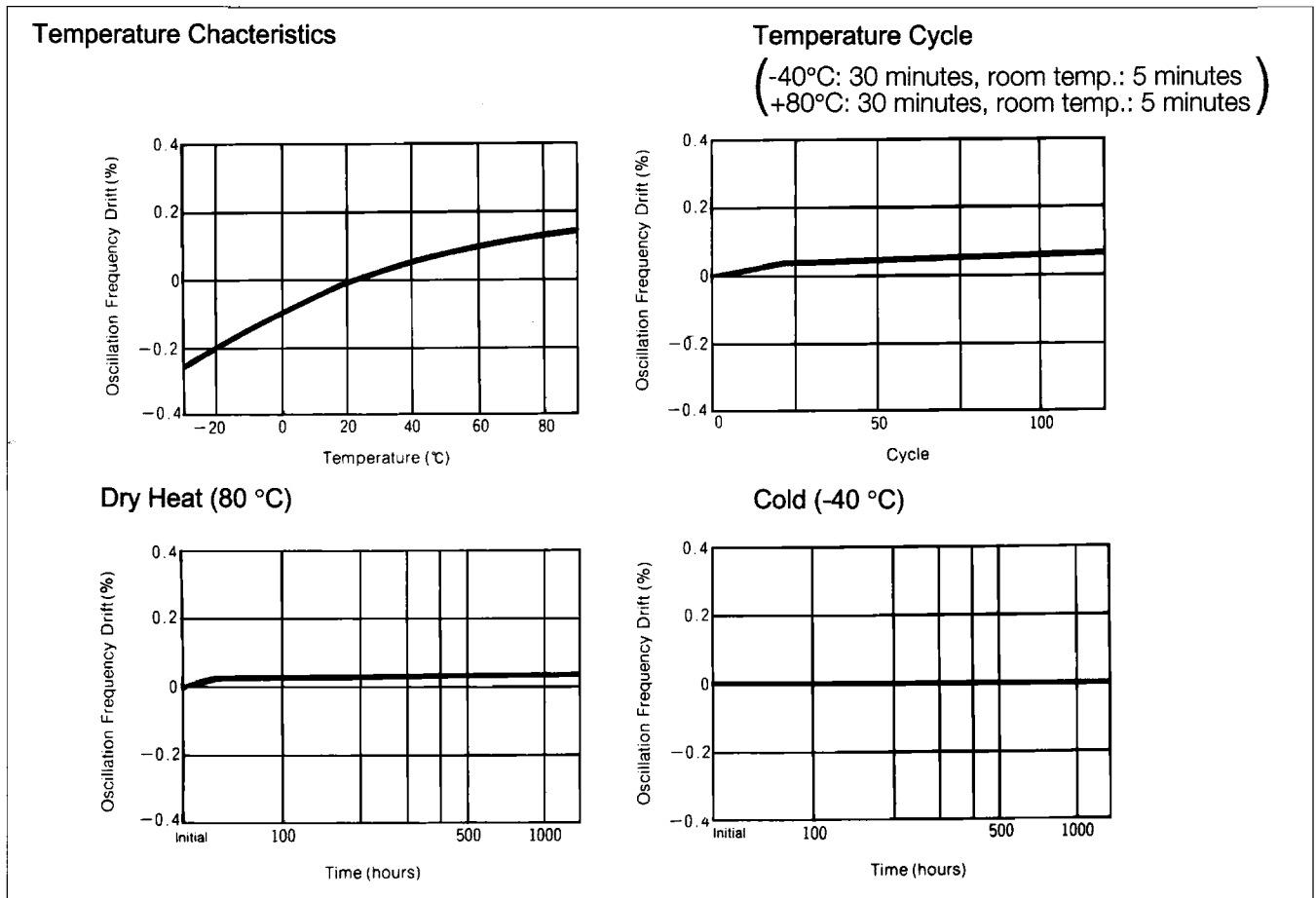

**Dimensions for taping in mm (not to scale)**

