

BIPOLAR DUAL OPERATIONAL AMPLIFIERS

- LOW DISTORTION RATIO
- LOW NOISE
- VERY LOW SUPPLY CURRENT
- LOW INPUT OFFSET CURRENT
- VERY LOW INPUT OFFSET VOLTAGE
- LARGE COMMON-MODE RANGE
- HIGH GAIN
- HIGH OUTPUT CURRENT
- GAIN-BANDWIDTH PRODUCT : 2.5 MHz
- TEMPERATURE DRIFT : $2 \mu\text{V}/^\circ\text{C}$
- LONG TERM STABILITY : $8 \mu\text{V}/\text{YEAR}$
(for $T_{\text{amb}} \leq 50^\circ\text{C}$)
- THE TEB1033 AND TEF1033 ARE PIN TO PIN REPLACEMENT OF THE LS204C AND LS204 RESPECTIVELY

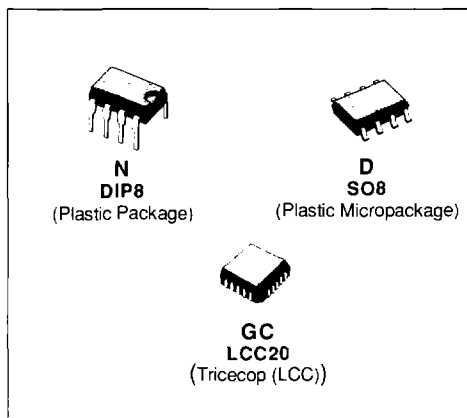

DESCRIPTION

The TEB1033, TEF1033 and TEC1033 are high performance dual-operational amplifiers intended for active filter applications. The internal phase compensation allows stable operation as voltage follower in spite of their high gain-bandwidth products.

The circuits present very stable electrical characteristics over the entire supply voltage range.

ORDER CODES

Part Number	Temperature Range	Package		
		N	D	GC
TEB1033	0 °C to + 70 °C	•	•	
TEF1033	- 40 °C to + 105 °C	•	•	
TEC1033	- 55 °C to + 125 °C			•

Examples : TEB1033N, TEC1033GC

PIN CONNECTIONS (top views)

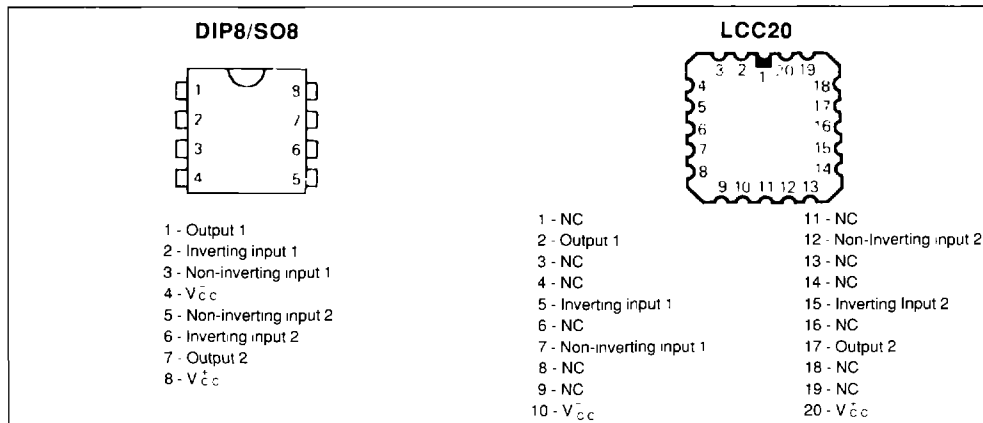

ABSOLUTE MAXIMUM RATINGS

Symbol	Parameter	Value	Unit
V_{CC}	Supply Voltage	± 18	V
V_I	Input Voltage	$\pm V_{CC}$	V
V_{ID}	Differential Input Voltage	$\pm (V_{CC} - 1)$	V
P_{tot}	Power Dissipation	TEB1033D, TEF1033D TEB1033N TEC1033GC	mW
T_{oper}	Operating Free-air Temperature Range	TEB1033 TEF1033 TEC1033	$^{\circ}\text{C}$
T_{stg}	Storage Temperature Range		$^{\circ}\text{C}$

BLOCK DIAGRAM

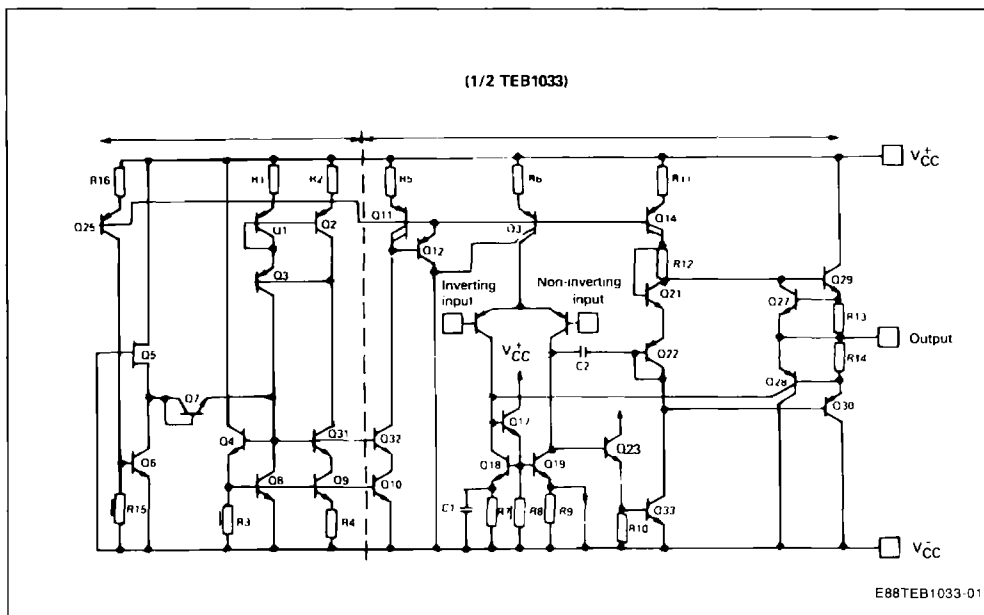

Case	Outputs	Inverting Inputs	Non-inverting Inputs	V_{CC}	V_{CC}	N. C.
DIP8 SO8	1, 7	2, 6	3, 5	8	4	
LCC20	2, 17	5, 15	7, 12	20	10	*

* LCC20 : Other pins are not connected.

ELECTRICAL CHARACTERISTICS

 $V_{CC} = \pm 15$ V (unless otherwise specified)**TEC 1033** : $-55 \leq T_{amb} \leq +125$ °C**TEF 1033** : $-40 \leq T_{amb} \leq +105$ °C**TEB 1033** : $0 \leq T_{amb} \leq +70$ °C

Symbol	Parameter	TEB 1033 TEF 1033 TEC 1033			Unit
		Min.	Typ.	Max.	
V_{IO}	Input Offset Voltage $T_{amb} = 25$ °C ($R_S \leq 10$ k Ω) $T_{min} \leq T_{amb} \leq T_{max}$		0.3	1 3	mV
DV_{IO}	Input Offset Voltage Drift		2		μ V/°C
I_{IO}	Input Offset Current $T_{amb} = 25$ °C $T_{min} \leq T_{amb} \leq T_{max}$		5	20 40	nA
I_{IB}	Input Bias Current $T_{amb} = 25$ °C $T_{min} \leq T_{amb} \leq T_{max}$		50	100 200	nA
A_{vd}	Large Signal Voltage Gain ($R_L = 2$ k Ω , $V_O = \pm 10$ V) $T_{amb} = 25$ °C $T_{min} \leq T_{amb} \leq T_{max}$	100 100	300		V/mV
SVR	Supply Voltage Rejection Ratio DV_{CC} from ± 15 V to ± 4 V $T_{amb} = 25$ °C $T_{min} \leq T_{amb} \leq T_{max}$	100 100	110		dB
I_{CC}	Supply Current, all Amp. no Load $T_{amb} = 25$ °C $T_{min} \leq T_{amb} \leq T_{max}$		1	1.5 2	mA
V_I	Input Voltage Range $T_{amb} = 25$ °C	- 12		+ 12	V
CMR	Common Mode Rejection Ratio ($R_S \leq 10$ k Ω , $V_I = \pm 10$ V) $T_{amb} = 25$ °C $T_{min} \leq T_{amb} \leq T_{max}$	100 100	110		dB
I_{OS}	Output Short-circuit Current $T_{amb} = 25$ °C $T_{min} \leq T_{amb} \leq T_{max}$	10 10	23	40 40	mA
$\pm V_{opp}$	Output Voltage Swing $T_{amb} = 25$ °C $T_{min} \leq T_{amb} \leq T_{max}$ $V_{CC} = \pm 4$ V, $R_L = 2$ k Ω $V_{CC} = \pm 6$ V, $R_L = 600$ Ω		13 12 2.8 4.6	14 3	V
S_{vo}	Slew-rate ($V_I = \pm 10$ V, $R_L = 2$ k Ω , $C_L \leq 100$ pF, $T_{amb} = 25$ °C, unity gain)	0.6	1	3	V/ μ s
GBP	Gain Bandwidth Product ($f = 100$ KHz, $T_{amb} = 25$ °C, $V_{IN} = 10$ mV, $R_L = 2$ k Ω , $C_L = 100$ pF)	1.8	2.5	3.2	MHz
R_I	Input Resistance ($T_{amb} = 25$ °C)		1		M Ω

ELECTRICAL CHARACTERISTICS(continued)

Symbol	Parameter	TEB 1033 TEF 1033 TEC 1033			Unit
		Min.	Typ.	Max.	
THD	Total Harmonic Distortion ($f = 1\text{KHz}$, $A_v = 20\text{ dB}$, $R_L = 2\text{ k}\Omega$ $C_L \leq 100\text{ pF}$, $T_{\text{amb}} = 25\text{ }^\circ\text{C}$, $V_o = 2\text{ V}_{\text{pp}}$)		0.008	0.05	%
V_n	Equivalent Input Noise Voltage ($f = 1\text{ KHz}$) $R_S = 50\ \Omega$ $R_S = 1\text{ k}\Omega$ $R_S = 10\text{ k}\Omega$		8 10 18	15	$\text{nV}/\sqrt{\text{Hz}}$
V_{OPP}	Large Signal Voltage Swing $R_L = 10\text{ k}\Omega$, $f = 10\text{ KHz}$	26	28		V
ϕ_M	Phase Margin		45		Degrees
V_{o1}/V_{o2}	Channel Separation	100	120		dB

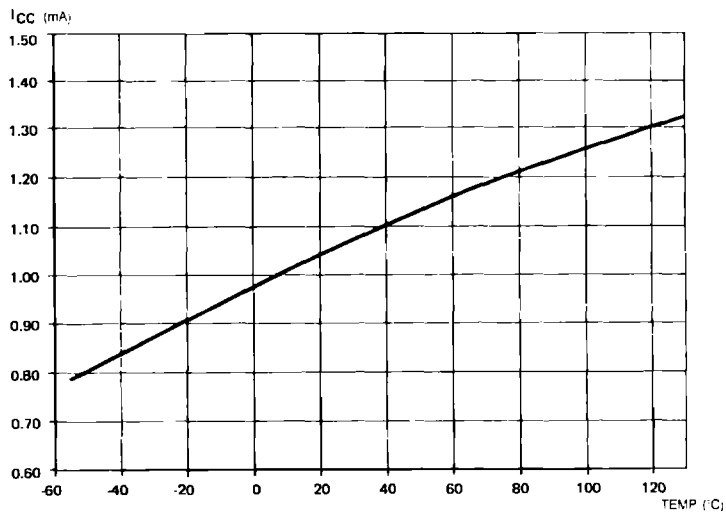

SUPPLY CURRENT VS. AMBIENT TEMPERATURE

E88TEB1033-02

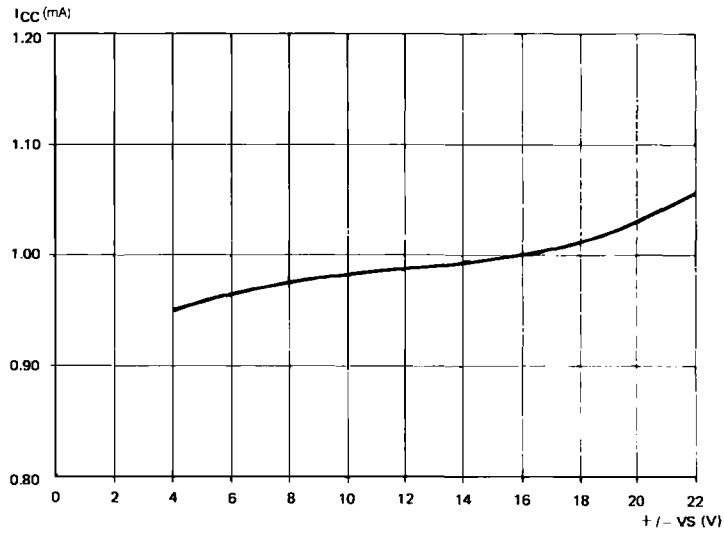

SUPPLY CURRENT VS. SUPPLY VOLTAGE

E88TEB1033-03

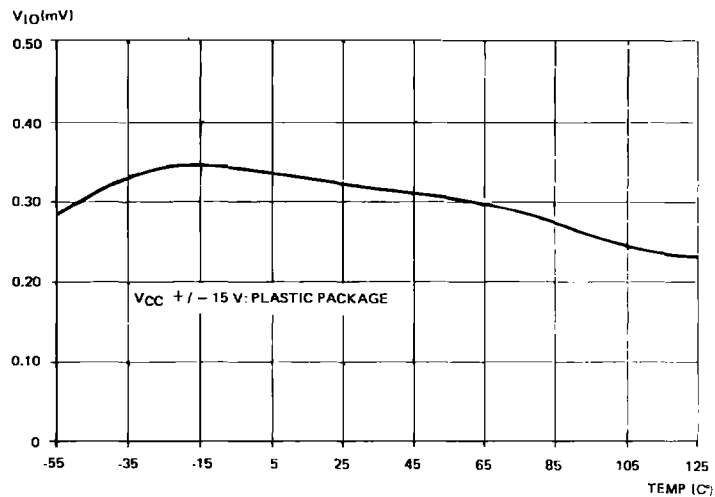

OFFSET VOLTAGE VS. AMBIENT TEMPERATURE

E88TEB1033-04

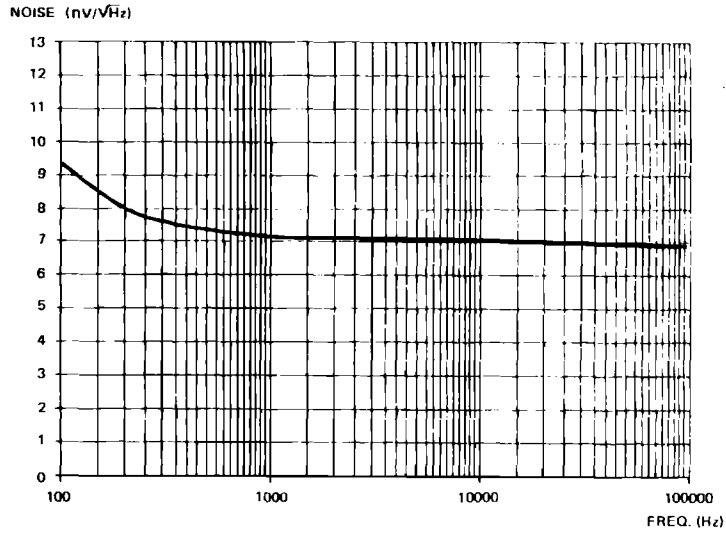

TOTAL INPUT NOISE VS. FREQUENCY

E88TEB1033-05

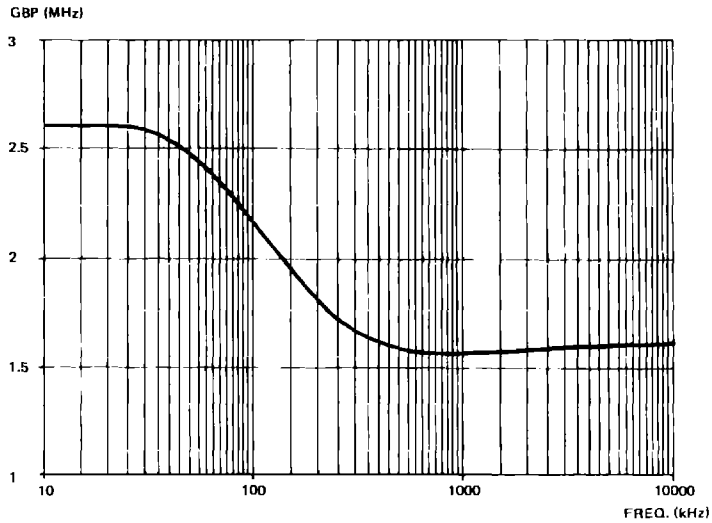

GAIN BANDWIDTH PRODUCT VS. FREQUENCY

E88TEB1033-06

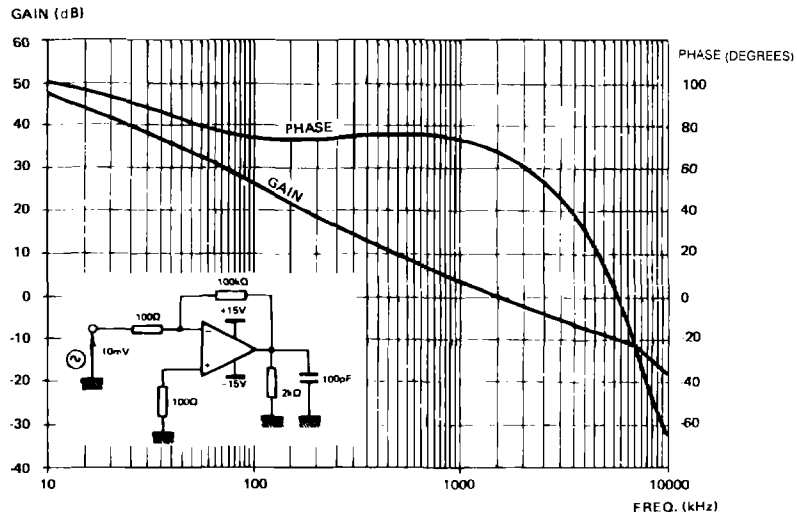

E88TEB1033-07

TYPICAL APPLICATION

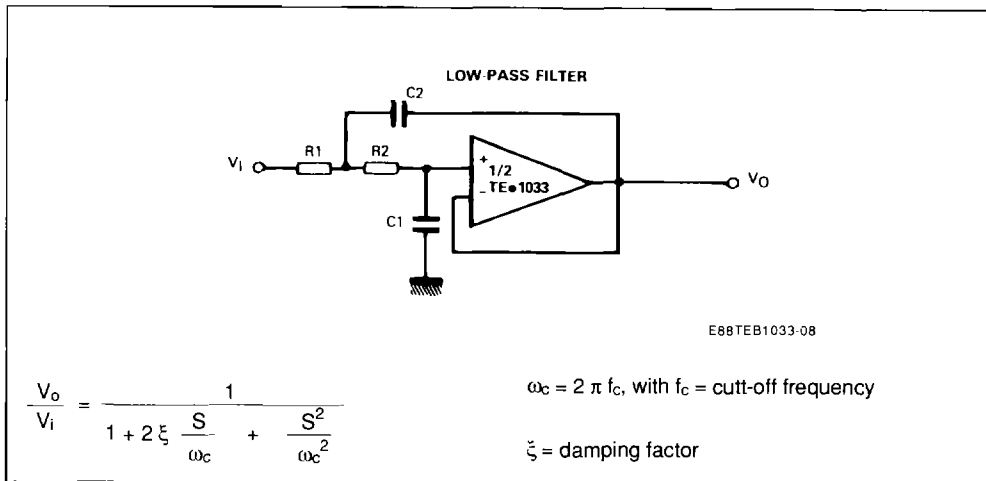

PACKAGE MECHANICAL DATA

8 PINS – PLASTIC DIP

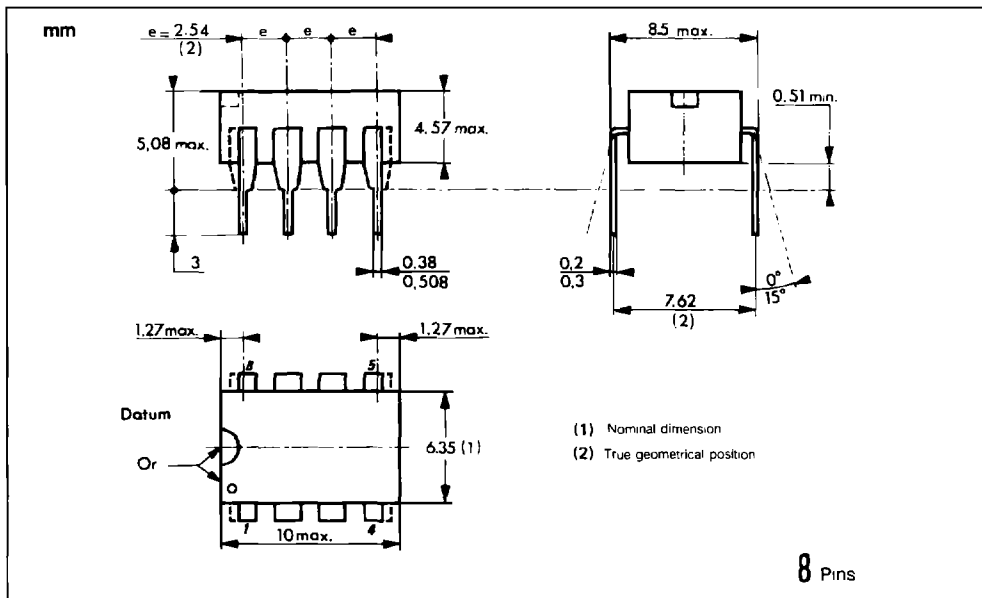

8 PINS – PLASTIC MICROPACKAGE (SO)

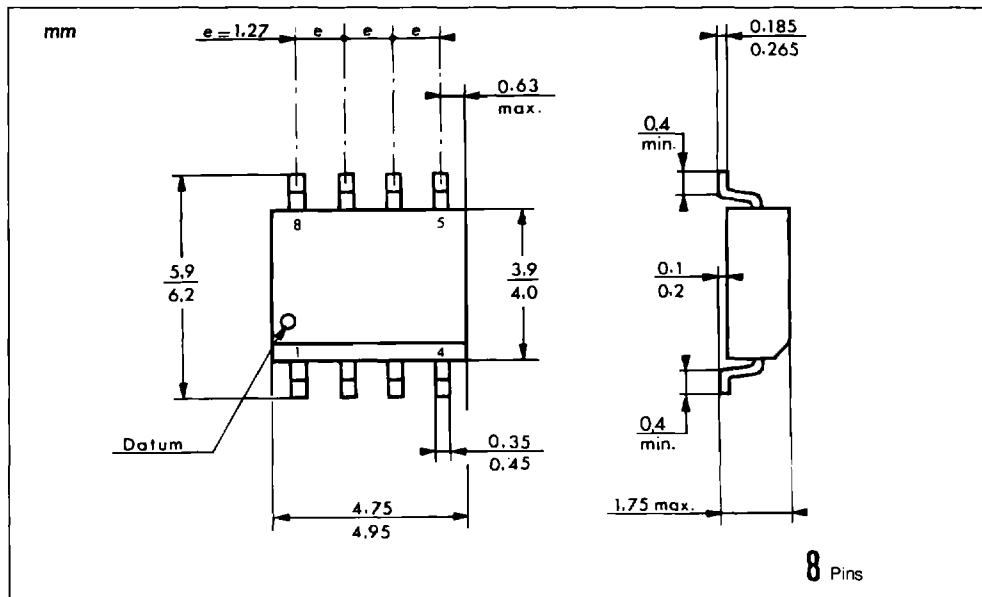

20 PINS – TRICOP (LCC)

