

CIRCUITS	ORDER NO.	DIM. C	DIM. D	DIM. A
2	89400-021*	2.00	0.75	6.00
3	89400-031*	4.00	2.00	8.00
4	89400-041*	6.00	4.00	10.00
5	89400-051*	8.00	6.00	12.00
6	89400-061*	10.00	8.00	14.00
7	89400-071*	12.00	10.00	16.00
8	89400-081*	14.00	12.00	18.00
9	89400-091*	16.00	14.00	20.00
10	89400-101*	18.00	16.00	22.00
11	89400-111*	20.00	18.00	24.00
12	89400-121*	22.00	20.00	26.00
13	89400-131*	24.00	22.00	28.00
14	89400-141*	26.00	24.00	30.00
15	89400-151*	28.00	26.00	32.00
16	89400-161*	30.00	28.00	34.00

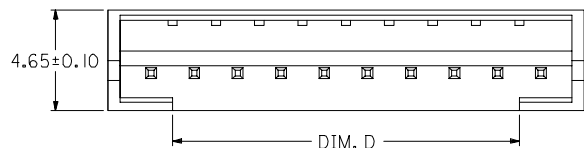
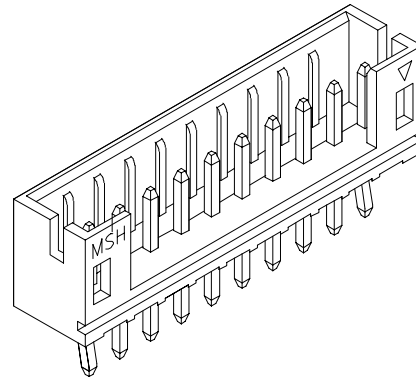
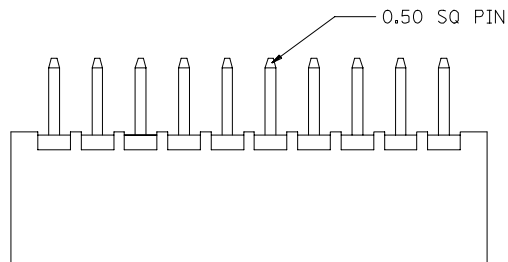

PART NO. LEGEND  
89400 - \*\*1\*

CKT SIZE

COLOR OPTION  
0 - NATURAL (WHITE)  
1 - BLACK  
2 - RED  
3 - YELLOW  
4 - BLUE  
6 - GREEN

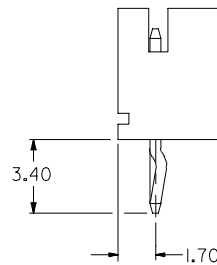
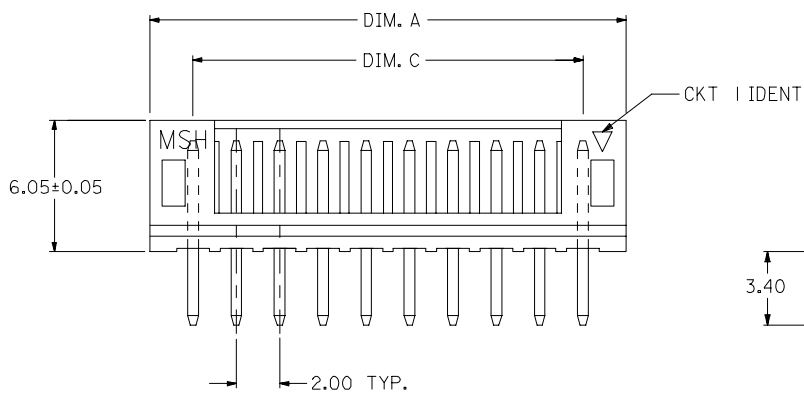

- NOTE:
- MATERIALS : HOUSING - NYLON (PA66), UL94 V-0  
COLOR : SEE OPTION  
TERMINAL - BRASS
  - FINISHES : TERMINAL - TIN THICKNESS 1.27-2.54 MICROMETER OVER  
NICKEL THICKNESS 2.54 MICROMETER MIN OVERALL  
COPPER THICKNESS 1.07 MICROMETER MIN OVERALL
  - PRODUCT SPECIFICATION : PS-87369-0001
  - BULK PACK IN PVC BAG WITH 1000 PCS PER BAG.

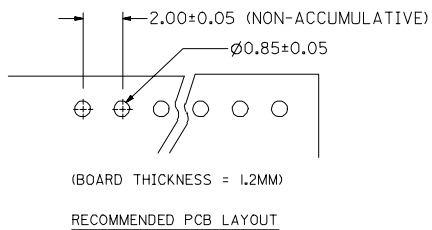

<b>NEW RELEASE</b> EC NO: SH2006-0288 DRWN:DHU 2005/12/07 CHKD:HARVEY 2005/12/08 APPR:GCHEN 2005/12/09	DESCRIPTION 2.00MM WIRE-BOARD STRAIGHT HEADER	QUALITY SYMBOLS ▽=0 ▽C=0	GENERAL TOLERANCES (UNLESS SPECIFIED)		DIMENSION STYLE <b>MM ONLY</b>		SCALE METRIC	DESIGN UNITS METRIC	THIRD ANGLE PROJECTION																			
			<table border="1"> <thead> <tr> <th></th> <th>mm</th> <th>INCH</th> </tr> </thead> <tbody> <tr><td>4 PLACES</td><td>±---</td><td>±---</td></tr> <tr><td>3 PLACES</td><td>±---</td><td>±---</td></tr> <tr><td>2 PLACES</td><td>±0.2</td><td>±---</td></tr> <tr><td>1 PLACE</td><td>±---</td><td>±---</td></tr> <tr><td colspan="3">ANGULAR ±---°</td></tr> </tbody> </table>		mm	INCH	4 PLACES	±---	±---	3 PLACES	±---	±---	2 PLACES	±0.2	±---	1 PLACE	±---	±---	ANGULAR ±---°			DRAWN BY GOH	DATE 1995/02/04	TITLE <b>2.00MM WIRE-BOARD STRAIGHT HEADER</b>				
			mm	INCH																								
		4 PLACES	±---	±---																								
3 PLACES	±---	±---																										
2 PLACES	±0.2	±---																										
1 PLACE	±---	±---																										
ANGULAR ±---°																												
		APPROVED BY (Signature)	DATE	MOLEX INCORPORATED																								
		DRAFT WHERE APPLICABLE MUST REMAIN WITHIN DIMENSIONS		MATERIAL NO. <b>SEE TABLE</b>		DOCUMENT NO. <b>SD-89400-**1*</b>	SHEET NO. 1 OF 1																					

SIZE A3 THIS DRAWING CONTAINS INFORMATION THAT IS PROPRIETARY TO MOLEX INCORPORATED AND SHOULD NOT BE USED WITHOUT WRITTEN PERMISSION

10 9 8 7 6 5 4 3 2 1

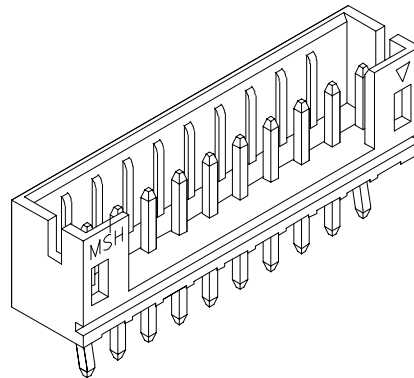
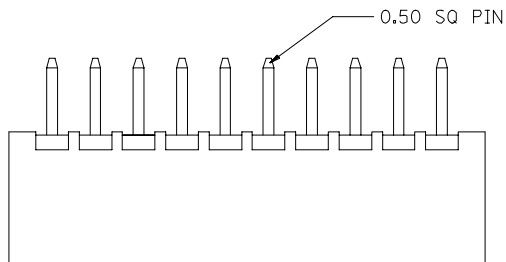

CIRCUITS	ORDER NO.	DIM. C	DIM. D	DIM. A
2	89400-021*	2.00	0.75	6.00
3	89400-031*	4.00	2.00	8.00
4	89400-041*	6.00	4.00	10.00
5	89400-051*	8.00	6.00	12.00
6	89400-061*	10.00	8.00	14.00
7	89400-071*	12.00	10.00	16.00
8	89400-081*	14.00	12.00	18.00
9	89400-091*	16.00	14.00	20.00
10	89400-101*	18.00	16.00	22.00
11	89400-111*	20.00	18.00	24.00
12	89400-121*	22.00	20.00	26.00
13	89400-131*	24.00	22.00	28.00
14	89400-141*	26.00	24.00	30.00
15	89400-151*	28.00	26.00	32.00
16	89400-161*	30.00	28.00	34.00

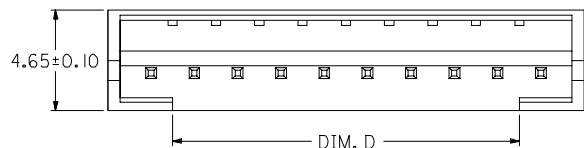

PART NO. LEGEND  
89400 - \*\*1\*

CKT SIZE

COLOR OPTION  
0 - NATURAL (WHITE)  
1 - BLACK  
2 - RED  
3 - YELLOW  
4 - BLUE  
6 - GREEN

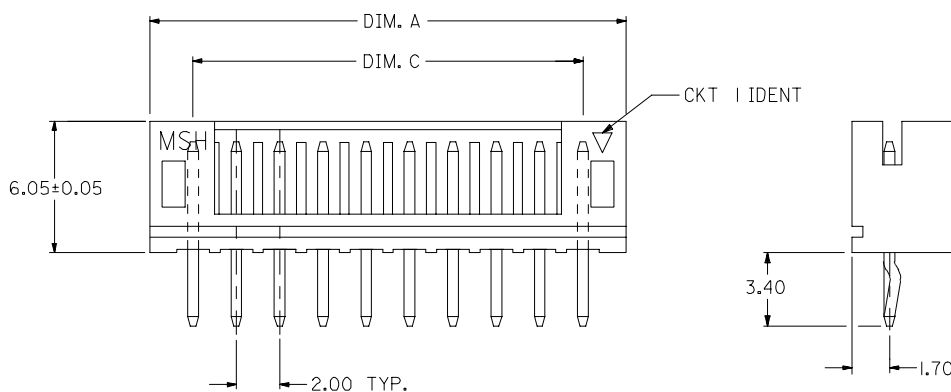

- NOTE:
- MATERIALS : HOUSING - NYLON (PA66), UL94 V-0  
COLOR : SEE OPTION  
TERMINAL - BRASS
  - FINISHES : TERMINAL - TIN THICKNESS 1.27-2.54 MICROMETER OVER  
NICKEL THICKNESS 2.54 MICROMETER MIN OVERALL  
COPPER THICKNESS 1.07 MICROMETER MIN OVERALL
  - PRODUCT SPECIFICATION : PS-87369-0001
  - BULK PACK IN PVC BAG WITH 1000 PCS PER BAG.

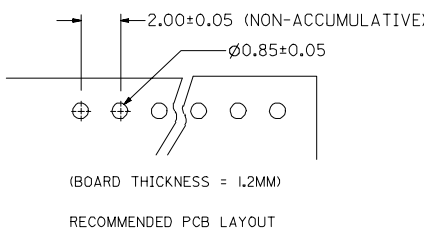

<b>NEW RELEASE</b> EC NO: SH2006-0288 DRWN:DHU 2005/12/07 CHKD:HARVEY 2005/12/08 APPR:GCHEN 2005/12/09	QUALITY SYMBOLS ▽=0 ▽C=0	GENERAL TOLERANCES (UNLESS SPECIFIED)		DIMENSION STYLE MM ONLY		SCALE	DESIGN UNITS METRIC	THIRD ANGLE PROJECTION		
				mm	INCH					
		4 PLACES	±---	±---	DRAWN BY GOH		DATE 1995/02/04	TITLE 2.00MM WIRE-BOARD STRAIGHT HEADER		
		3 PLACES	±---	±---	CHECKED BY		DATE	MOLEX INCORPORATED		
2 PLACES	±0.2	±---	APPROVED BY		DATE	MATERIAL NO.		DOCUMENT NO.	SHEET NO.	
1 PLACE	±---	±---	ANGULAR ±---°		SEE TABLE		SD-89400-**1*		1 OF 1	
DRAFT WHERE APPLICABLE MUST REMAIN WITHIN DIMENSIONS		SIZE A3		THIS DRAWING CONTAINS INFORMATION THAT IS PROPRIETARY TO MOLEX INCORPORATED AND SHOULD NOT BE USED WITHOUT WRITTEN PERMISSION						

9 8 7 6 5 4 3 2 1