

DO NOT SCALE FROM THIS PRINT

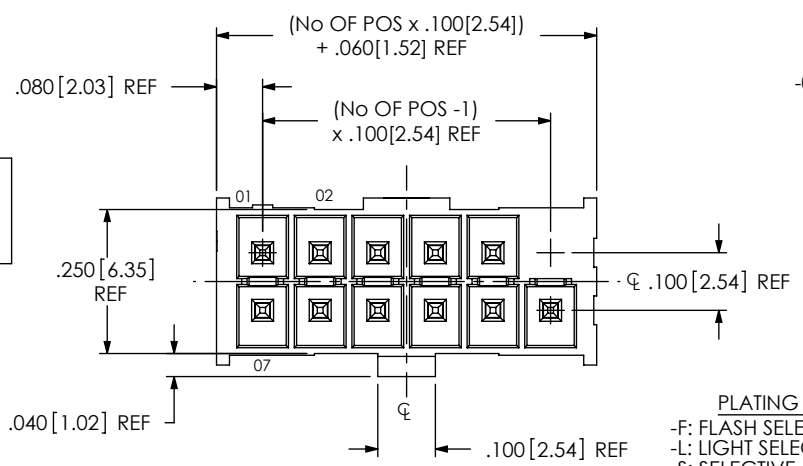

FIG. 1
IPL1-106-01-XXX-D-P SHOWN

IPL1-1XX-XX-XXX-D-XX-X

No OF POSITIONS
-02 THRU -25
(PER ROW)

LEAD STYLE
-01: THROUGH HOLE
(USE T-1S64-XX-XX)
-02: SURFACE MOUNT
(SEE FIG. 2, SHT 2)
(USE T-1S64-XX-XX)

OPTION
-P: POLARIZATION (SEE FIG. 1)
(USE IPL1-XX-D-P)
(NOT AVAILABLE W/ -K, OPTIONS)
-K: KEYED POLARIZATION
(USE IPL1-XX-D-K)
(SEE FIG. 5, SHEET 3)
(NOT AVAILABLE W/ -P, OPTIONS)

(LEAVE BLANK FOR NO POLARIZATION
(SEE FIG. 4, SHEET 3), SAMTEC WILL ONLY SUPPORT
EXISTING BUSINESS AS OF REV. U)

OPTION
-RA: RIGHT ANGLE (SEE FIG. 3, SHT 2)
(AVAILABLE WITH -01 LEAD STYLE ONLY)

ROW SPECIFICATION
-D: DOUBLE (USE IPL1-XX-D)

PLATING SPECIFICATION
-F: FLASH SELECTIVE (USE T-1S64-XX-F)
-L: LIGHT SELECTIVE (USE T-1S64-XX-L)
-S: SELECTIVE (USE T-1S64-XX-S)
-H: HEAVY GOLD (T-1S64-XX-H)
-FM: FLASH SELECTIVE/MATTE TIN TAILS (USE T-1S64-XX-F)
-LM: LIGHT SELECTIVE/MATTE TIN TAILS (USE T-1S64-XX-L)
-SM: SELECTIVE/MATTE TIN TAILS (USE T-1S64-XX-S)
-STL: SELECTIVE/ TIN/LEAD TAILS (USE T-1S64-XX-STL)

** NOT RELEASED FOR PRODUCTION

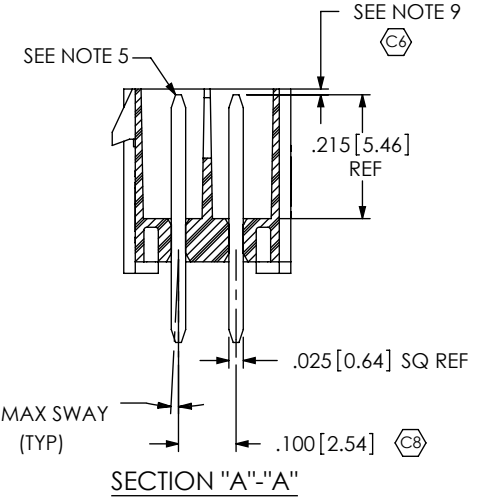
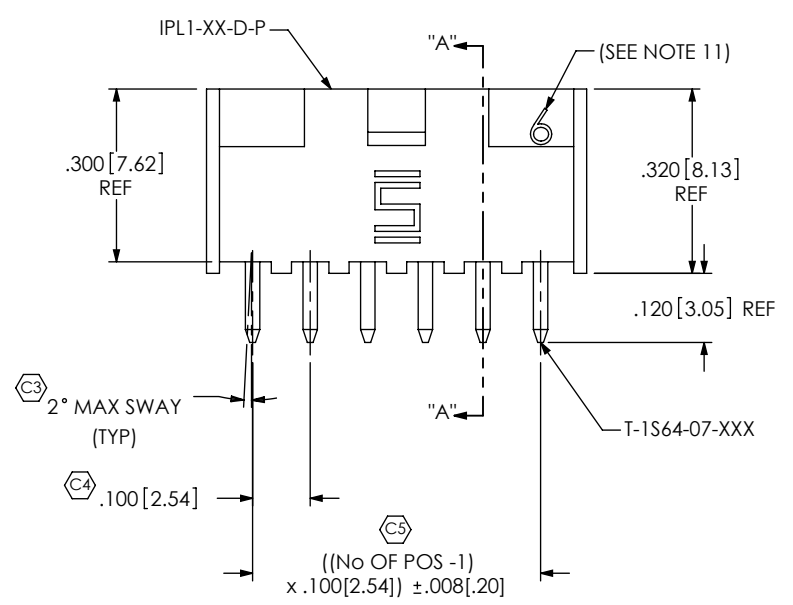

SECTION "A"- "A"

- NOTES:
1. Ⓢ REPRESENTS A CRITICAL DIMENSION.
 2. NOTE DELETED.
 3. MINIMUM TERMINAL RETENTION: 1 LB.
 4. PARTS TO BE MOLDED TO POSITION.
 5. POST MUST BE WITHIN .005 [1.3] OF EACH OTHER.
 6. ALL PIN TO PIN DIMENSIONS TO BE MEASURED FROM TIP TO TIP.
 7. NOTE DELETED.
 8. DIMENSION TO BE MEASURED AT BEND.
 9. TIP TO BE FLUSH TO .015 BELOW TOP OF SHROUD.
 10. BOTH ROWS TO BE SYMMETRIC WITHIN .010 [0.25].
 11. THIS NUMBER REPRESENTS THE NUMBER OF POSITIONS PER ROW ONLY AND IS NOT INTENDED TO BE USED IN POSITION NUMBERING.

LEAD STYLE	OPTION	TERMINAL 1	OAL REF	TERMINAL 2	OAL REF
-01	NONE	T-1S64-07-X	.430 [10.92]	N/A	N/A
-01	-RA	T-1S64-09-X	.530 [13.46]	T-1S64-10-X	.730 [18.54]
-02	NONE	T-1S64-08-X	.445 [11.30]	N/A	N/A

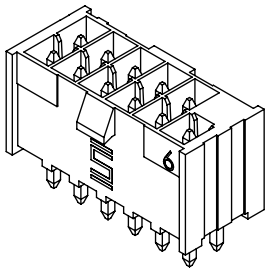

UNLESS OTHERWISE SPECIFIED, DIMENSIONS ARE IN INCHES.
TOLERANCES ARE:
DECIMALS ANGLES
.XX: ±.01 [.3] ± 2°
.XXX: ±.005 [.13]
.XXXX: ±.0020 [.051]

PROPRIETARY NOTE
THIS DOCUMENT CONTAINS INFORMATION CONFIDENTIAL AND PROPRIETARY TO SAMTEC, INC. AND SHALL NOT BE REPRODUCED OR TRANSFERRED TO OTHER DOCUMENTS OR DISCLOSED TO OTHERS OR USED FOR ANY PURPOSE OTHER THAN THAT WHICH IT WAS OBTAINED WITHOUT THE EXPRESSED WRITTEN CONSENT OF SAMTEC, INC.

samtec
520 PARK EAST BLVD, NEW ALBANY, IN 47150
PHONE: 812-944-6733 FAX: 812-948-5047
e-Mail: info@SAMTEC.com code: 55322

MATERIAL: DO NOT SCALE DRAWING SHEET SCALE: 3:1 DESCRIPTION: .100 [2.54] DOUBLE ROW TERMINAL ASSEMBLY
INSULATOR: LCP, COLOR: BLACK
-K INSULATOR: LCP, COLOR: NATURAL
TERMINAL: PHOS BRONZE
DWG. NO. **IPL1-1XX-XX-XXX-D-XX-X**
BY: KEVIN B 03/11/02 SHEET 1 OF 3

F:\DWG\MISC\MKTG\IPL1-1XX-XX-XXX-D-XX-X-MKT.SLDRW

FIG. 2
IPL1-106-02-XXX-D-P SHOWN
[DIFFERENT AS SHOWN, OTHERWISE SAME AS FIG. 1]

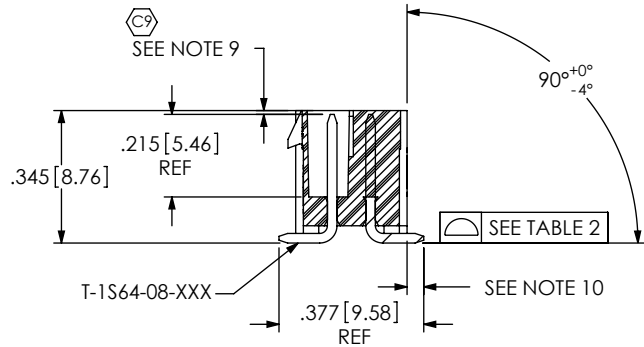

No OF POS.	COPLANARITY
-02 THRU -05	.004[.10]
-06 THRU -10	.005[.13]
-11 THRU -25	.006[.15]

-02: SURFACE MOUNT INPROCESS 1

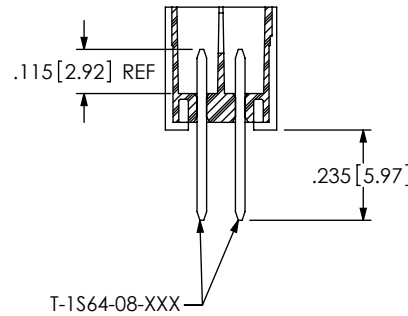

-02: SURFACE MOUNT INPROCESS 2

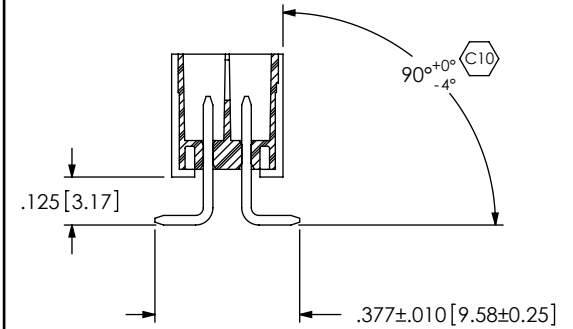

PACKAGING VIEWS
(ASSEMBLIES TO HAVE POSITION #1 LOADED IN THE SAME DIRECTION AS ARROW ON TUBE, EXCEPT WITH -RA OPTION)

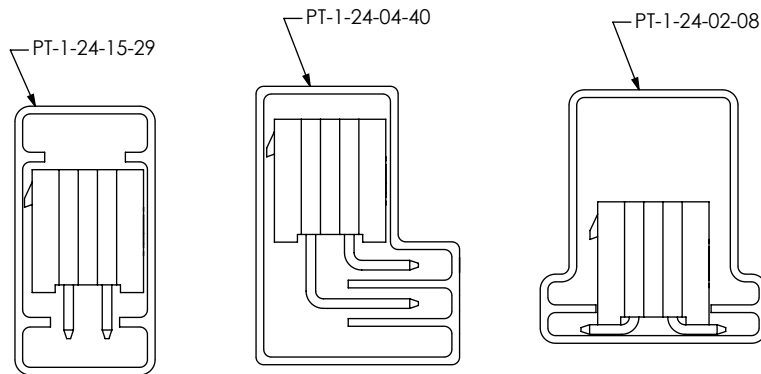

LEAD STYLE	OPTION	PACKAGING TUBE	PLUG
-01	NONE	PT-1-24-15-29	TP-07
-01	-RA	PT-1-24-04-40	TP-07
-02	NONE	PT-1-24-02-08	TP-13

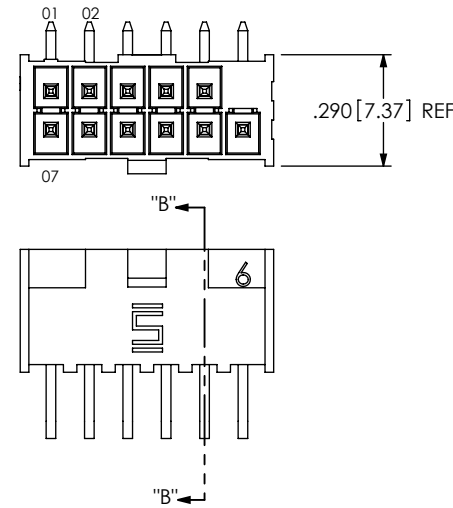
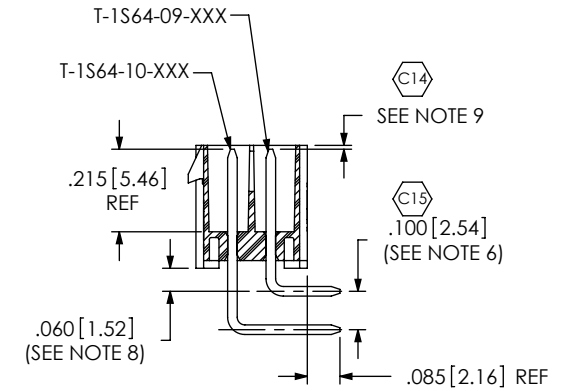

FIG. 3
IPL1-106-01-XXX-D-RA-P SHOWN
(DIFFERENT AS SHOWN, OTHERWISE SAME AS FIG. 1)



SECTION "B"- "B"

F:\DWG\MISC\MKTG\IPL1-1XX-XX-XXX-D-XX-X-MKT.SLDDRW

PROPRIETARY NOTE
THIS DOCUMENT CONTAINS INFORMATION CONFIDENTIAL AND PROPRIETARY TO SAMTEC, INC. AND SHALL NOT BE REPRODUCED OR TRANSFERRED TO OTHER DOCUMENTS OR DISCLOSED TO OTHERS OR USED FOR ANY PURPOSE OTHER THAN THAT WHICH IT WAS OBTAINED WITHOUT THE EXPRESSED WRITTEN CONSENT OF SAMTEC, INC.

DO NOT SCALE DRAWING

SHEET SCALE: 2:1



520 PARK EAST BLVD, NEW ALBANY, IN 47150
PHONE: 812-944-6733 FAX: 812-948-5047
e-Mail: info@SAMTEC.com code: 55322

DESCRIPTION:
.100[2.54] DOUBLE ROW TERMINAL ASSEMBLY

DWG. NO.
IPL1-1XX-XX-XXX-D-XX-X

BY: KEVIN B 03/11/02 SHEET 2 OF 3

REVISION Y

-RA: INPROCESS 1

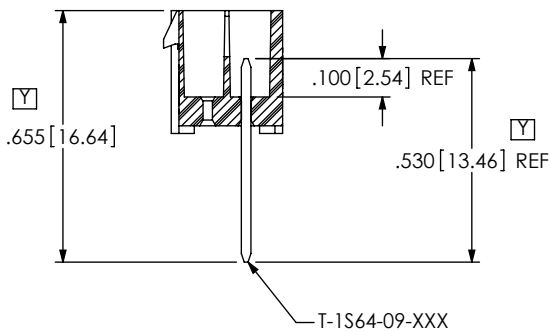

-RA: INPROCESS 2

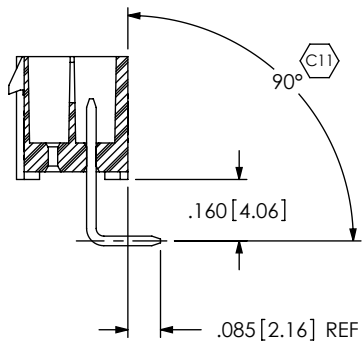

-RA: INPROCESS 3

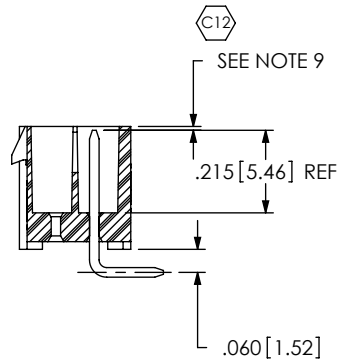

-RA: INPROCESS 4

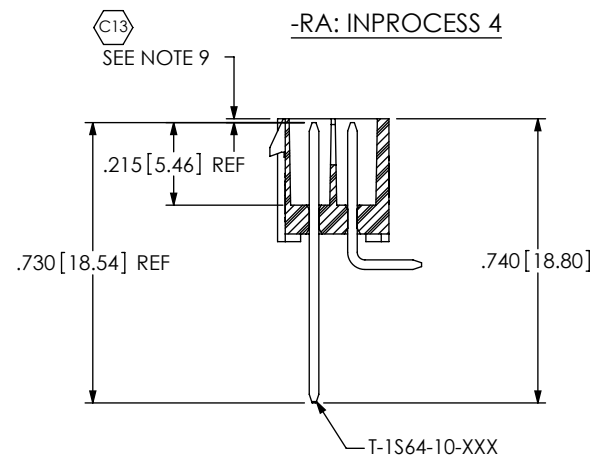

FIG. 4
(IPL1-106-01-XXX-D SHOWN)
(DIFFERENT AS SHOWN,
OTHERWISE SAME AS FIG. 1)
**SAMTEC WILL ONLY SUPPORT
EXISTING BUSINESS AS OF REV. U)**

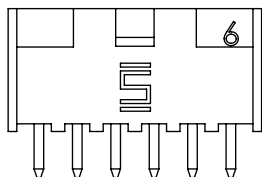
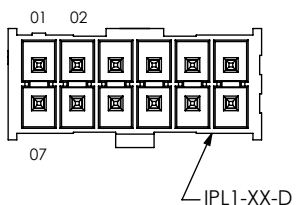
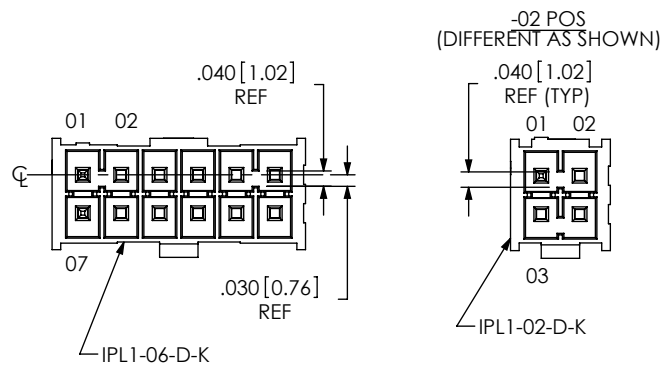

FIG. 5
(IPL1-106-01-XXX-D-K SHOWN)
(DIFFERENT AS SHOWN, OTHERWISE SAME AS FIG. 4)



PROPRIETARY NOTE

THIS DOCUMENT CONTAINS INFORMATION
CONFIDENTIAL AND PROPRIETARY TO
SAMTEC, INC. AND SHALL NOT BE REPRODUCED
OR TRANSFERRED TO OTHER DOCUMENTS OR
DISCLOSED TO OTHERS OR USED FOR ANY
PURPOSE OTHER THAN THAT WHICH IT WAS
OBTAINED WITHOUT THE EXPRESSED WRITTEN
CONSENT OF SAMTEC, INC.

DO NOT SCALE DRAWING

SHEET SCALE: 2:1

samtec

520 PARK EAST BLVD, NEW ALBANY, IN 47150
PHONE: 812-944-6733 FAX: 812-948-5047
e-Mail: info@SAMTEC.com code: 55322

DESCRIPTION:
.100[2.54] DOUBLE ROW TERMINAL ASSEMBLY

DWG. NO.
IPL1-1XX-XX-XXX-D-XX-X

BY: KEVIN B 03/11/02 SHEET 3 OF 3