

---

## 3-MODE 150mA LDO REGULATOR with the Reverse Current Protection

---

NO.EA-118-081118

### OUTLINE

The R1163x Series consist of CMOS-based voltage regulator ICs with high output voltage accuracy and low supply current. These ICs perform with the chip enable function and realize a standby mode with ultra low supply current. To prevent the destruction by over current, the current limit circuit is included. The R1163x Series have 3-mode. One is standby mode with CE or standby control pin. Other two modes are realized with ECO pin. Fast Transient Mode (FT mode) and Low Power Mode (LP mode) are alternative with ECO pin. Consumption current is reduced at Low Power Mode compared with Fast Transient Mode. The output voltage is maintained between FT mode and LP mode.

Further, the reverse current protection circuit is built-in. Therefore, if a higher voltage than  $V_{DD}$  pin is forced to the output pin, the reverse current to  $V_{DD}$  pin is very small (Max.  $0.1\mu A$ ), so it is suitable for backup circuit.

Since the packages for these ICs are SOT-23-5, SON-6, and DFN(PLP)1616-6 packages, high density mounting of the ICs on boards is possible.

### FEATURES

- Supply Current ..... Typ.  $6.0\mu A$  (Low Power Mode),  
Typ.  $70\mu A$  (Fast Transient Mode)
- Standby Mode ..... Typ.  $0.6\mu A$
- Reverse Current..... Max.  $0.1\mu A$
- Input Voltage Range ..... 2.0V to 6.0V
- Output Voltage ..... Stepwise setting with a step of 0.1V  
in the range of 1.5V to 5.0V is possible
- Output Voltage Accuracy.....  $\pm 1.5\%$  ( $\pm 2.5\%$  at Low Power Mode)
- Temperature-Drift Coefficient of Output Voltage .. Typ.  $\pm 100\text{ppm}/^\circ\text{C}$
- Dropout Voltage ..... Typ. 0.25V ( $I_{OUT}=150\text{mA}$ ,  $V_{OUT}=2.8\text{V}$ )
- Ripple Rejection..... Typ. 70dB ( $f=1\text{kHz}$ , Fast Transient Mode)
- Line Regulation ..... Typ. 0.02%/V (Fast Transient Mode)
- Package ..... DFN(PLP)1616-6, SON-6, SOT-23-5
- Built-in fold-back protection circuit ..... Typ. 40mA (Current at short mode)
- Performs with Ceramic Capacitors .....  $C_{IN}=\text{Ceramic } 1.0\mu\text{F}$ ,  $C_{OUT}=\text{Ceramic } 0.47\mu\text{F}$

### APPLICATIONS

- Precision Voltage References.
- Power source for electrical appliances such as cameras, VCRs and hand-held communication equipment.
- Power source for battery-powered equipment.

**BLOCK DIAGRAM**

**R1163xxx1B**

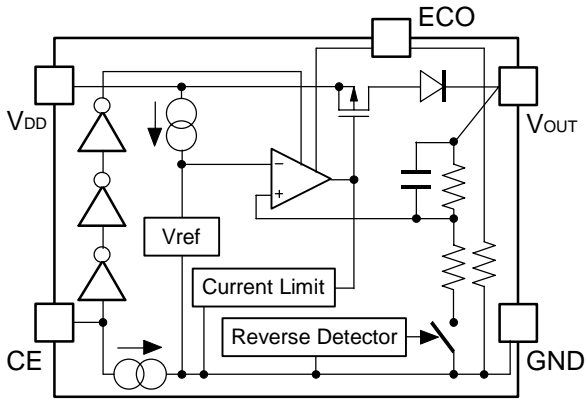

**R1163xxx1D**

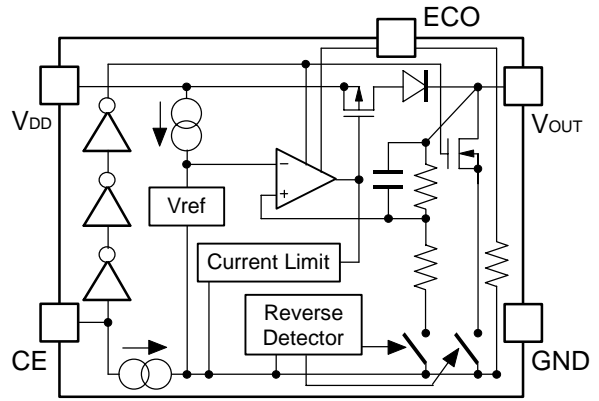

**R1163xxx1E**

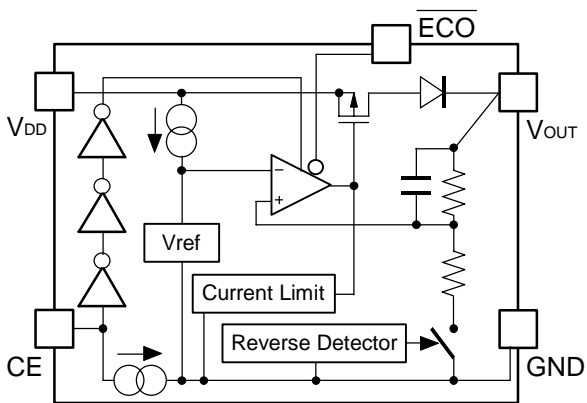

## SELECTION GUIDE

The output voltage, the auto-discharge function\*, the package and the taping type for the ICs can be selected at the user's request. The selection can be available by designating the part number as shown below;

R1163xxx1x-xx-x ←Part Number  
 ↑↑ ↑ ↑ ↑  
 a b c d e

Code	Contents
a	Designation of Package Type : N: SOT-23-5 D: SON-6 K: DFN(PLP)1616-6
b	Setting Output Voltage (V <sub>OUT</sub> ) : Stepwise setting with a step of 0.1V in the range of 1.5V to 5.0V is possible. Exceptions: 1.85V=R1163x181x5-xx-x, 2.75V=R1163x271x5-xx-x, 2.85V=R1163x281x5-xx-x
c	Designation of Chip Enable Option : B: "H" active type and without the auto-discharge function*. D: "H" active and with the auto-discharge function*. E: "H" active type and without auto-discharge function*. ECO logic reverse type (Low Power mode at ECO="H")
d	Designation of Taping Type : Refer to Taping Specifications;TR type is the standard direction.
e	Designation of composition of pin plating: -F : Lead free solder plating (SOT-23-5, SON-6) None: Au plating (DFN(PLP)1616-6)

\*) When the mode is into standby with CE signal, auto discharge transistor turns on, and it makes the turn-off speed faster than normal type.

## PIN CONFIGURATIONS

• SOT-23-5

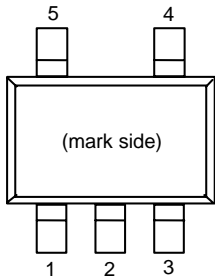

• SON-6

Top View

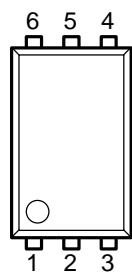

Bottom View

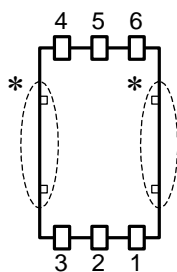

• DFN(PLP)1616-6

Top View

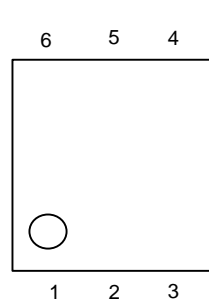

Bottom View

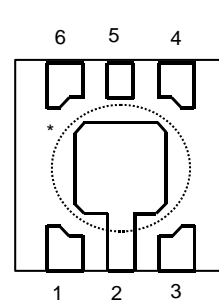

## PIN DISCRIPTIONS

• SOT-23-5

Pin No	Symbol	Pin Description
1	V <sub>DD</sub>	Input Pin
2	GND	Ground Pin
3	CE	Chip Enable Pin
4	ECO/ $\overline{\text{ECO}}$	MODE alternative pin
5	V <sub>OUT</sub>	Output pin

• SON-6

Pin No	Symbol	Pin Description
1	V <sub>DD</sub>	Input Pin
2	NC	No Connection
3	V <sub>OUT</sub>	Output pin
4	ECO/ $\overline{\text{ECO}}$	MODE alternative pin
5	GND	Ground Pin
6	CE	Chip Enable Pin

\*) Tab in the  parts have GND level.  
(They are connected to the back side of this IC.)  
Do not connect to other wires or land patterns.

• DFN(PLP)1616-6

Pin No	Symbol	Pin Description
1	V <sub>OUT</sub>	Output pin
2	GND	Ground Pin
3	ECO/ $\overline{\text{ECO}}$	MODE alternative pin
4	CE	Chip Enable pin
5	NC	No Connection
6	V <sub>DD</sub>	Input Pin

\*) Tab in the  parts have GND level.  
(They are connected to the back side of this IC.)  
Do not connect to other wires or land patterns.

## ABSOLUTE MAXIMUM RATINGS

Symbol	Item	Rating	Unit
$V_{IN}$	Input Voltage	6.5	V
$V_{ECO}$	Input Voltage (ECO/ $\overline{ECO}$ Pin)	-0.3 ~ 6.5	V
$V_{CE}$	Input Voltage (CE Pin)	-0.3 ~ 6.5	V
$V_{OUT}$	Output Voltage	-0.3 ~ 6.5	V
$I_{OUT}$	Output Current	180	mA
$P_D$	Power Dissipation (SOT-23-5) *	420	mW
	Power Dissipation (SON-6) *	500	
	Power Dissipation (DFN(PLP)1616-6)*	560	
$T_{opt}$	Operating Temperature Range	-40 ~ 85	°C
$T_{stg}$	Storage Temperature Range	-55 ~ 125	°C

\*) For Power Dissipation, please refer to PACKAGE INFORMATION to be described.

### ABSOLUTE MAXIMUM RATINGS

Electronic and mechanical stress momentarily exceeded absolute maximum ratings may cause the permanent damages and may degrade the life time and safety for both device and system using the device in the field.

The functional operation at or over these absolute maximum ratings is not assured.

### RECOMMENDED OPERATING CONDITIONS (ELECTRICAL CHARACTERISTICS)

All of electronic equipment should be designed that the mounted semiconductor devices operate within the recommended operating conditions. The semiconductor devices cannot operate normally over the recommended operating conditions, even if when they are used over such conditions by momentary electronic noise or surge. And the semiconductor devices may receive serious damage when they continue to operate over the recommended operating conditions.

## ELECTRICAL CHARACTERISTICS

R1163xxx1B/D

T<sub>opt</sub>=25°C

Symbol	Item		Conditions	Min.	Typ.	Max.	Unit	
V <sub>OUT</sub>	Output Voltage	FT Mode	V <sub>IN</sub> =Set V <sub>OUT</sub> +1V, V <sub>ECO</sub> =V <sub>IN</sub> 1mA ≤ I <sub>OUT</sub> ≤ 30mA	×0.985		×1.015	V	
		LP Mode	V <sub>IN</sub> =Set V <sub>OUT</sub> +1V, V <sub>ECO</sub> =GND 1mA ≤ I <sub>OUT</sub> ≤ 30mA	×0.975		×1.025		
ΔV <sub>OUT</sub>	Output Voltage Deviation between FT Mode and LP Mode		V <sub>IN</sub> =Set V <sub>OUT</sub> +1V, I <sub>OUT</sub> =30mA	V <sub>OUT</sub> > 2.0V	-1.2	0	1.2	%
				V <sub>OUT</sub> ≤ 2.0V	-24	0	24	mV
I <sub>OUT</sub>	Output Current		V <sub>IN</sub> -V <sub>OUT</sub> =1.0V	150			mA	
ΔV <sub>OUT</sub> / ΔI <sub>OUT</sub>	Load Regulation	FT Mode	V <sub>IN</sub> =Set V <sub>OUT</sub> +1V, V <sub>ECO</sub> =V <sub>IN</sub> 1mA ≤ I <sub>OUT</sub> ≤ 150mA		20	40	mV	
		LP Mode	V <sub>IN</sub> =Set V <sub>OUT</sub> +1V, V <sub>ECO</sub> =GND 1mA ≤ I <sub>OUT</sub> ≤ 150mA		20	45		
V <sub>DIF</sub>	Dropout Voltage		Refer to the following table					
I <sub>SS1</sub>	Supply Current (FT Mode)		V <sub>IN</sub> =Set V <sub>OUT</sub> +1V V <sub>ECO</sub> =V <sub>IN</sub>		70	100	μA	
I <sub>SS2</sub>	Supply Current (LP Mode)		V <sub>IN</sub> =Set V <sub>OUT</sub> +1V V <sub>ECO</sub> =GND		6.0	10.0	μA	
I <sub>standby</sub>	Supply Current (Standby)		V <sub>IN</sub> =Set V <sub>OUT</sub> +1V, V <sub>CE</sub> =GND V <sub>ECO</sub> =GND or V <sub>IN</sub>		0.6	1.0	μA	
ΔV <sub>OUT</sub> / ΔV <sub>IN</sub>	Line Regulation	FT Mode	Set V <sub>OUT</sub> +0.5V ≤ V <sub>IN</sub> ≤ 6.0V I <sub>OUT</sub> =30mA, V <sub>ECO</sub> =V <sub>IN</sub> If V <sub>OUT</sub> ≤ 1.6V, then 2.2V ≤ V <sub>IN</sub> ≤ 6.0V		0.02	0.10	%V	
		LP Mode	Set V <sub>OUT</sub> +0.5V ≤ V <sub>IN</sub> ≤ 6.0V I <sub>OUT</sub> =30mA, V <sub>ECO</sub> =GND If V <sub>OUT</sub> ≤ 1.6V, then 2.2V ≤ V <sub>IN</sub> ≤ 6.0V		0.05	0.20		
RR	Ripple Rejection (FT Mode)		Ripple 0.2V <sub>p-p</sub> , V <sub>IN</sub> =Set V <sub>OUT</sub> +1V, I <sub>OUT</sub> =30mA, V <sub>ECO</sub> =V <sub>IN</sub> If V <sub>OUT</sub> ≤ 1.7V, then V <sub>IN</sub> =Set V <sub>OUT</sub> +1.2V	f=1kHz		70	dB	
				f=10kHz		60		
V <sub>IN</sub>	Input Voltage			2.0		6.0	V	
ΔV <sub>OUT</sub> / ΔT <sub>opt</sub>	Output Voltage Temperature Coefficient		I <sub>OUT</sub> =30mA -40°C ≤ T <sub>opt</sub> ≤ 85°C		±100		ppm/°C	
I <sub>lim</sub>	Short Current Limit		V <sub>OUT</sub> =0V		40		mA	
I <sub>PD</sub>	CE Pull-down Current				0.3	0.6	μA	
R <sub>PE</sub>	ECO Pull-down Resistance			2	5	30	MΩ	
V <sub>CEH</sub>	CE, ECO Input Voltage "H"			1.0		6.0	V	
V <sub>CEL</sub>	CE, ECO Input Voltage "L"			0		0.35	V	
en	Output Noise "H" (FT Mode)		BW=10Hz to 100kHz		30		μVrms	
	Output Noise "L" (LP Mode)		BW=10Hz to 100kHz		40			
R <sub>LOW</sub>	Low Output Nch Tr. ON Resistance (of D version)		V <sub>CE</sub> =0V		60		Ω	
I <sub>REV</sub>	Reverse Current		V <sub>OUT</sub> >0.5V, 0V ≤ V <sub>IN</sub> ≤ 6V		0	0.1	μA	

## R1163xxx1E

T<sub>opt</sub>=25°C

Symbol	Item	Conditions	Min.	Typ.	Max.	Unit	
V <sub>OUT</sub>	Output Voltage	FT Mode	V <sub>IN</sub> =Set V <sub>OUT</sub> +1V, V <sub>ECO</sub> =GND 1mA ≤ I <sub>OUT</sub> ≤ 30mA	×0.985		×1.015	V
		LP Mode	V <sub>IN</sub> =Set V <sub>OUT</sub> +1V, V <sub>ECO</sub> =V <sub>IN</sub> 1mA ≤ I <sub>OUT</sub> ≤ 30mA	×0.975		×1.025	
ΔV <sub>OUT</sub>	Output Voltage Deviation between FT Mode and LP Mode	V <sub>IN</sub> =Set V <sub>OUT</sub> +1V, I <sub>OUT</sub> =30mA	V <sub>OUT</sub> > 2.0V	-1.2	0	1.2	%
			V <sub>OUT</sub> ≤ 2.0V	-24	0	24	mV
I <sub>OUT</sub>	Output Current	V <sub>IN</sub> -V <sub>OUT</sub> =1.0V	150			mA	
ΔV <sub>OUT</sub> / ΔI <sub>OUT</sub>	Load Regulation	FT Mode	V <sub>IN</sub> =Set V <sub>OUT</sub> +1V, V <sub>ECO</sub> =GND 1mA ≤ I <sub>OUT</sub> ≤ 150mA		20	40	mV
		LP Mode	V <sub>IN</sub> =Set V <sub>OUT</sub> +1V, V <sub>ECO</sub> =V <sub>IN</sub> 1mA ≤ I <sub>OUT</sub> ≤ 150mA		20	45	
V <sub>DIF</sub>	Dropout Voltage	Refer to the following table					
I <sub>SS1</sub>	Supply Current (FT Mode)	V <sub>IN</sub> =Set V <sub>OUT</sub> +1V V <sub>ECO</sub> =GND		70	100	μA	
I <sub>SS2</sub>	Supply Current (LP Mode)	V <sub>IN</sub> =Set V <sub>OUT</sub> +1V V <sub>ECO</sub> =V <sub>IN</sub>		6.0	10.0	μA	
I <sub>standby</sub>	Supply Current (Standby)	V <sub>IN</sub> =Set V <sub>OUT</sub> +1V, V <sub>CE</sub> =GND V <sub>ECO</sub> =GND or V <sub>IN</sub>		0.6	1.0	μA	
ΔV <sub>OUT</sub> / ΔV <sub>IN</sub>	Line Regulation	FT Mode	Set V <sub>OUT</sub> +0.5V ≤ V <sub>IN</sub> ≤ 6.0V I <sub>OUT</sub> =30mA, V <sub>ECO</sub> =GND If V <sub>OUT</sub> ≤ 1.6V, then 2.2V ≤ V <sub>IN</sub> ≤ 6.0V		0.02	0.10	%V
		LP Mode	Set V <sub>OUT</sub> +0.5V ≤ V <sub>IN</sub> ≤ 6.0V I <sub>OUT</sub> =30mA, V <sub>ECO</sub> =V <sub>IN</sub> If V <sub>OUT</sub> ≤ 1.6V, then 2.2V ≤ V <sub>IN</sub> ≤ 6.0V		0.05	0.20	
RR	Ripple Rejection (FT Mode)	Ripple 0.2V <sub>p-p</sub> V <sub>IN</sub> =Set V <sub>OUT</sub> +1V, I <sub>OUT</sub> =30mA, V <sub>ECO</sub> =GND If V <sub>OUT</sub> ≤ 1.7V, then V <sub>IN</sub> =Set V <sub>OUT</sub> +1.2V	f = 1kHz		70		dB
			f = 10kHz		60		
V <sub>IN</sub>	Input Voltage		2.0		6.0	V	
ΔV <sub>OUT</sub> / ΔT <sub>opt</sub>	Output Voltage Temperature Coefficient	I <sub>OUT</sub> = 30mA -40°C ≤ T <sub>opt</sub> ≤ 85°C		±100		ppm/°C	
I <sub>lim</sub>	Short Current Limit	V <sub>OUT</sub> = 0V		40		mA	
I <sub>PD</sub>	CE Pull-down Current			0.3	0.6	μA	
V <sub>CEH</sub>	CE, $\overline{\text{ECO}}$ Input Voltage "H"		1.0		6.0	V	
V <sub>CEL</sub>	CE, $\overline{\text{ECO}}$ Input Voltage "L"		0		0.4	V	
en	Output Noise "H" (FT Mode)	BW = 10Hz to 100kHz		30		μVrms	
	Output Noise "L" (LP Mode)	BW = 10Hz to 100kHz		40			
I <sub>REV</sub>	Reverse Current	V <sub>OUT</sub> >0.5V, 0V ≤ V <sub>IN</sub> ≤ 6V		0	0.1	μA	

## ELECTRICAL CHARACTERISTICS by OUTPUT VOLTAGE

T<sub>opt</sub>=25°C

Output Voltage V <sub>OUT</sub> (V)	Dropout Voltage (mV)				
	Condition	V <sub>DIF</sub> (ECO=H)		V <sub>DIF</sub> (ECO=L)	
		Typ.	Max.	Typ.	Max.
1.5 ≤ V <sub>OUT</sub> < 1.6	I <sub>OUT</sub> =150mA	400	680	420	680
1.6 ≤ V <sub>OUT</sub> < 1.7		380	550	390	550
1.7 ≤ V <sub>OUT</sub> < 1.8		350	520	370	520
1.8 ≤ V <sub>OUT</sub> < 2.0		340	490	350	490
2.0 ≤ V <sub>OUT</sub> < 2.8		290	425	300	430
2.8 ≤ V <sub>OUT</sub> ≤ 5.0		250	350	250	350

## TYPICAL APPLICATION

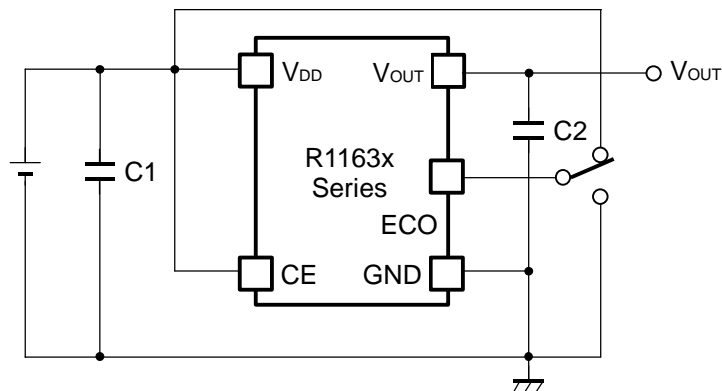

(External Components)

Ex. C1: Ceramic Capacitor 1.0μF

C2: Ceramic Capacitor 0.47μF Murata GRM40B474K  
Kyocera CM105B474K

## TECHNICAL NOTES

When using these ICs, consider the following points:

### Phase Compensation

In these ICs, phase compensation is made for securing stable operation even if the load current is varied. For this purpose, be sure to use a 0.47μF or more ceramic capacitor C2.

(Test these ICs with as same external components as ones to be used on the PCB.)

When a tantalum capacitor is used with this IC, if the equivalent series resistor (ESR) of the capacitor is large, output voltage may be unstable.

### PCB Layout

Make V<sub>DD</sub> and GND lines sufficient. If their impedance is high, noise pickup or unstable operation may result. Connect a capacitor C1 with as much as 1.0μF capacitor between V<sub>DD</sub> and GND pin as close as possible.

Set external components such as an output capacitor C2, as close as possible to the ICs and make wiring as short as possible.



## TEST CIRCUITS

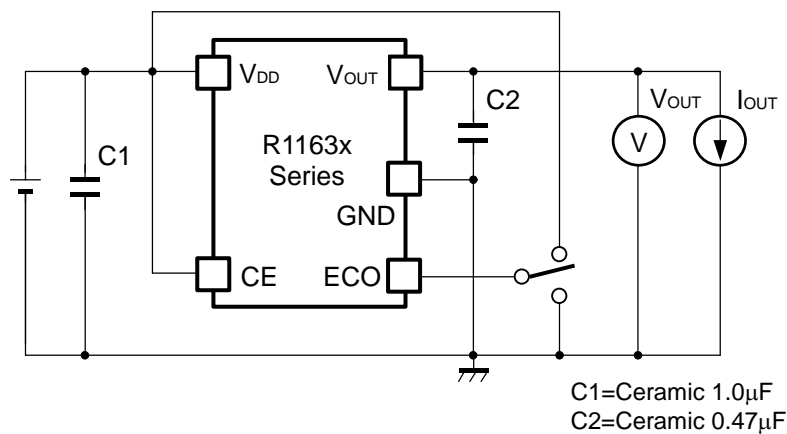

Basic Test Circuit

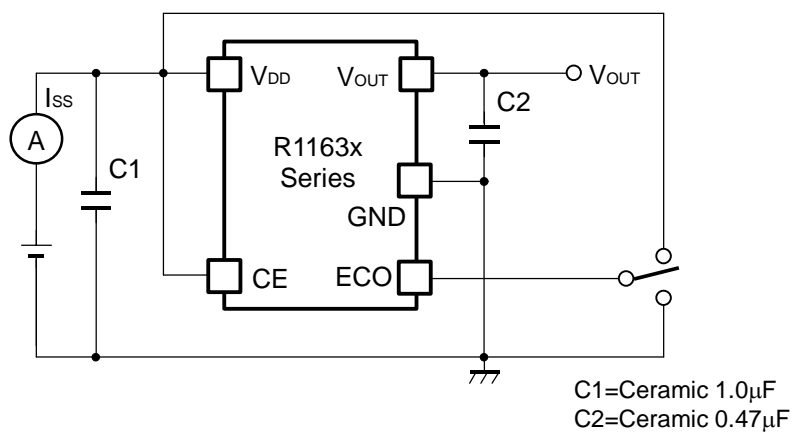

Test Circuit for Supply Current

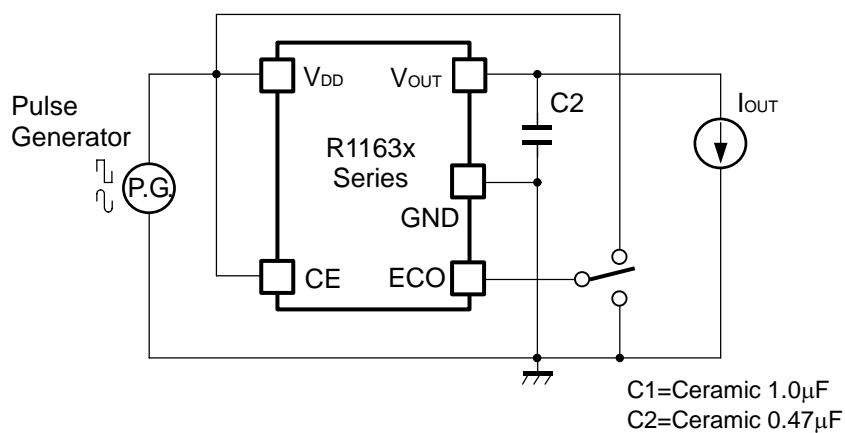

Test Circuit for Ripple Rejection, Line Transient Response

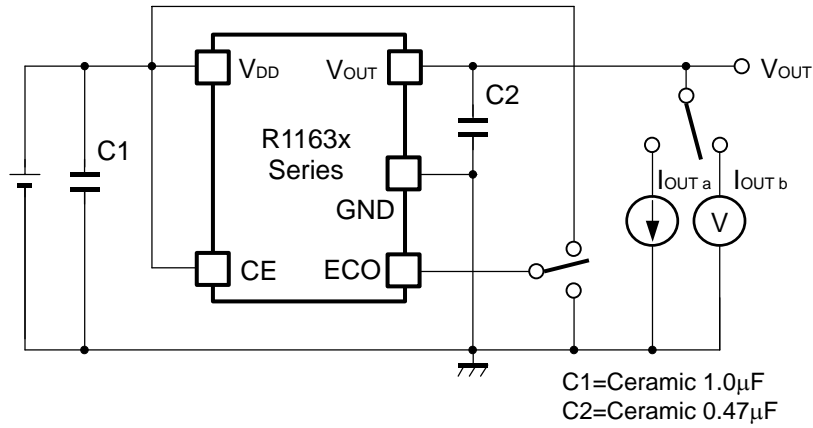

**Test Circuit for Load Transient Response**

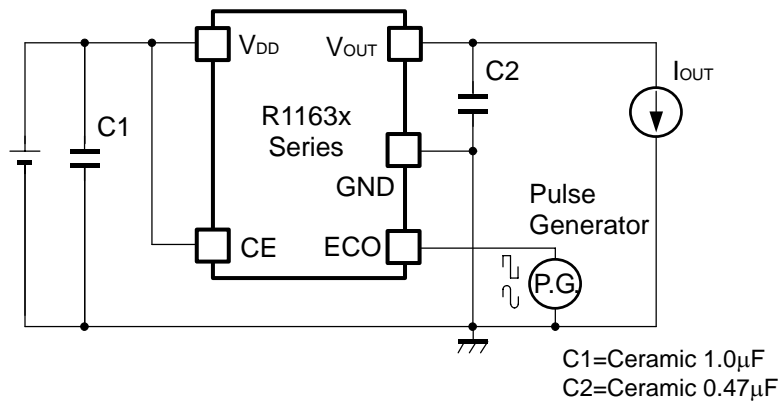

**Test Circuit for Output Voltage at Mode alternative point**

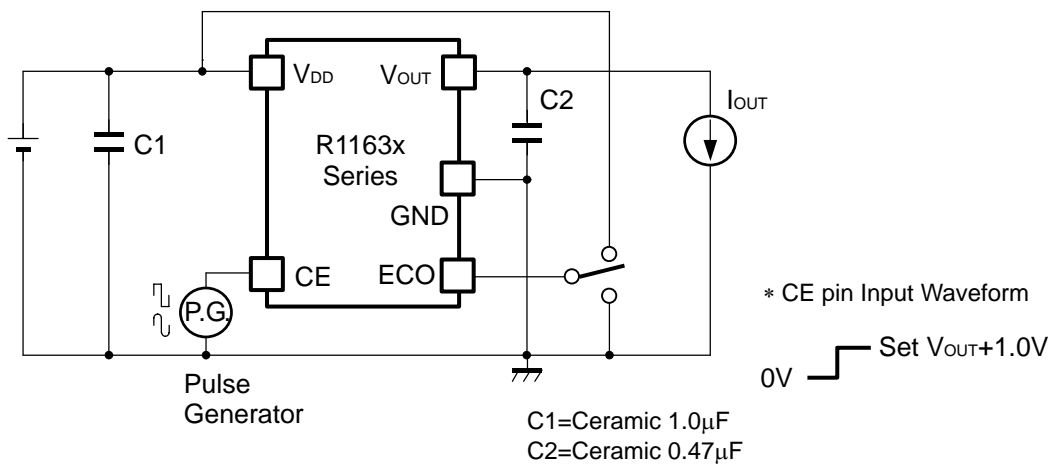

**Test Circuit for Turn On Speed with CE pin**

## TYPICAL CHARACTERISTICS

Unless otherwise provided, capacitors are ceramic type.

### 1) Output Voltage vs. Output Current

R1163x151x ECO=H

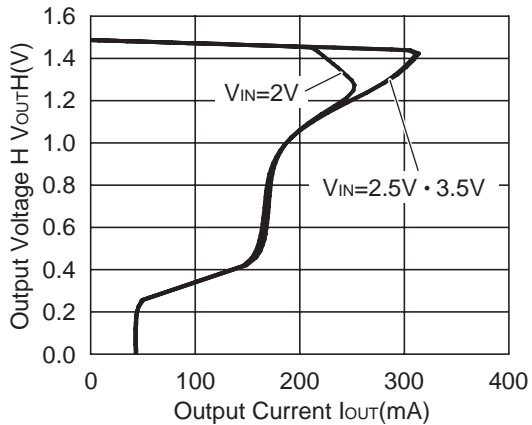

R1163x151x ECO=L

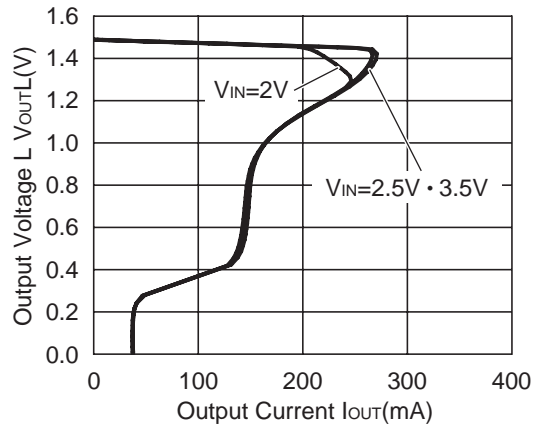

R1163x281x ECO=H

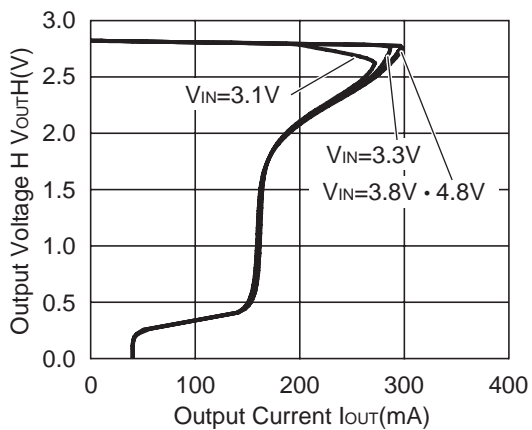

R1163x281x ECO=L

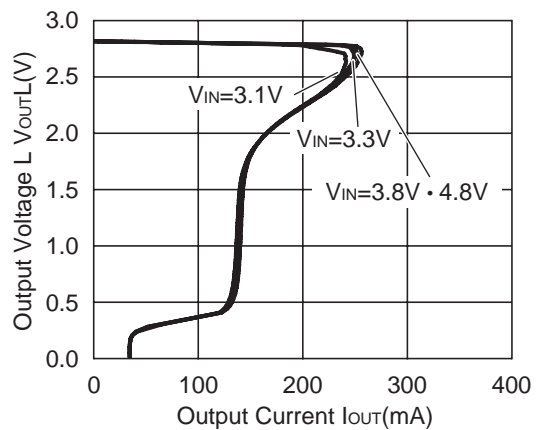

R1163x40x ECO=H

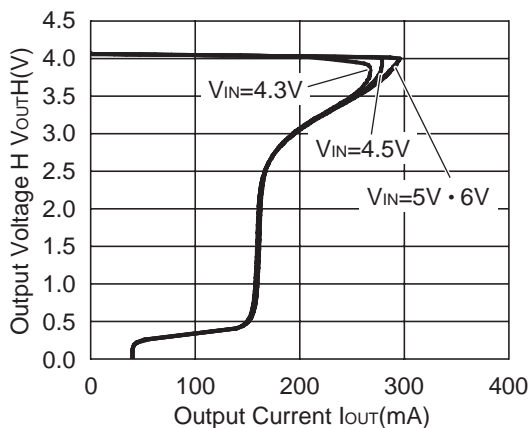

R1163x40x ECO=L

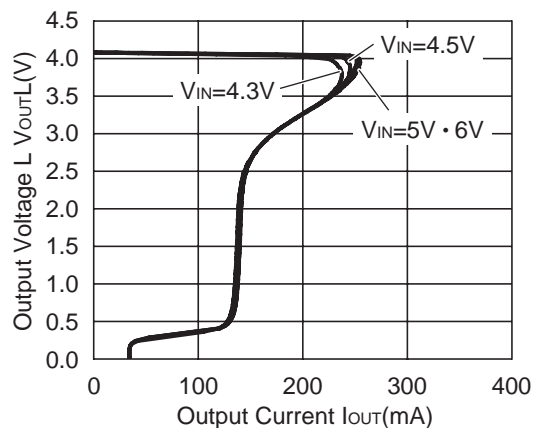

2) Output Voltage vs. Input Voltage

R1163x151x ECO=H

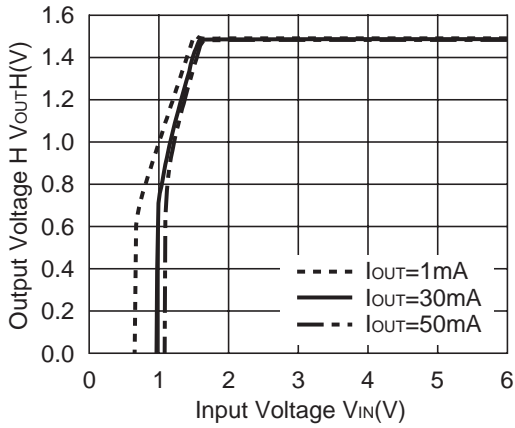

R1163x15x ECO=L

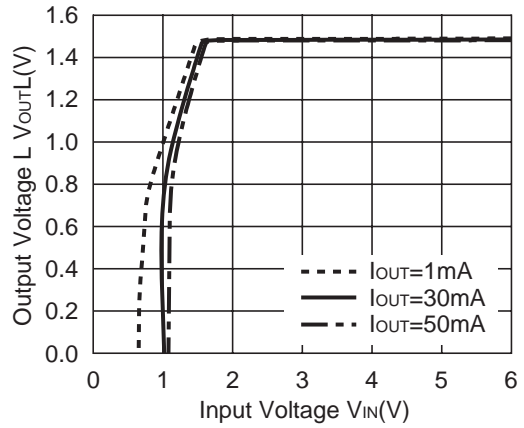

R1163x28x ECO=H

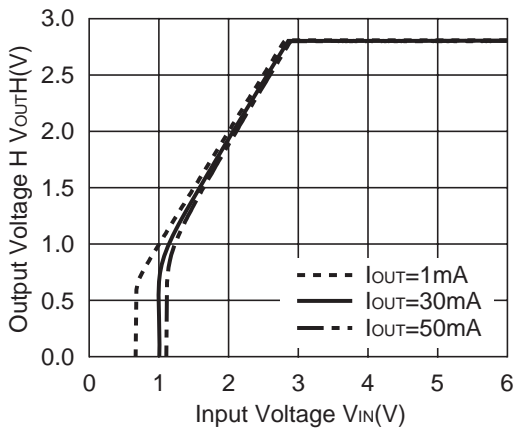

R1163x28x ECO=L

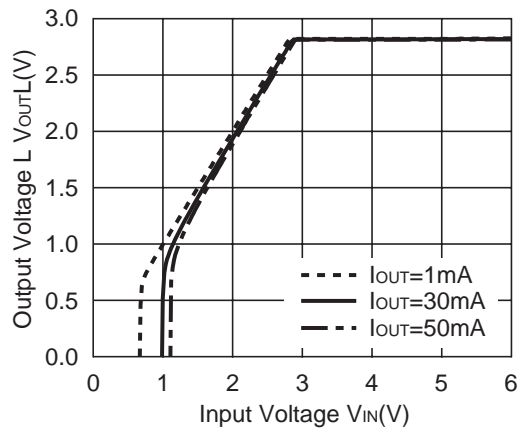

R1163x40x ECO=H

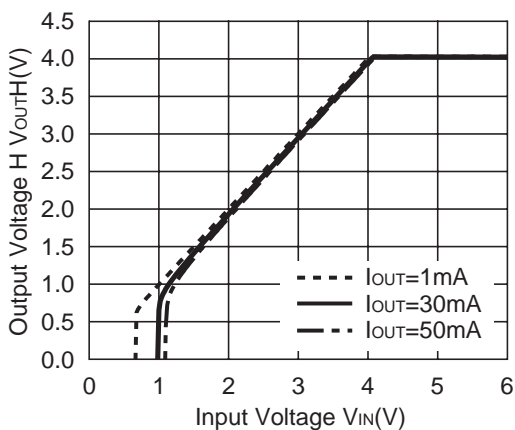

R1163x40x ECO=L

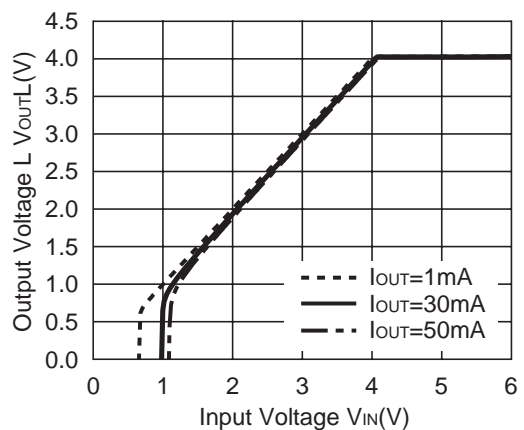

### 3) Supply Current vs. Input Voltage

**R1163x151x ECO=H**

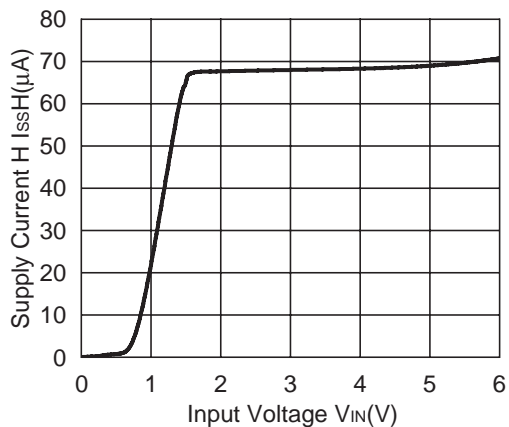

**R1163x151x ECO=L**

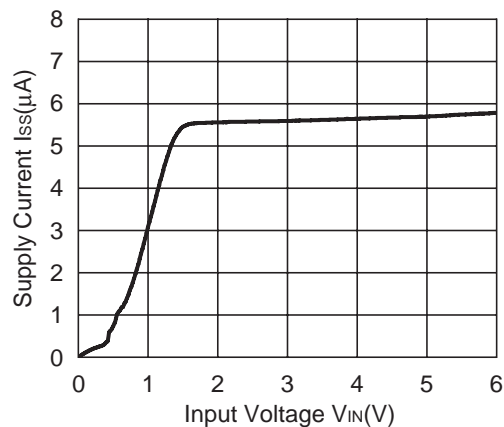

**R1163x281x ECO=H**

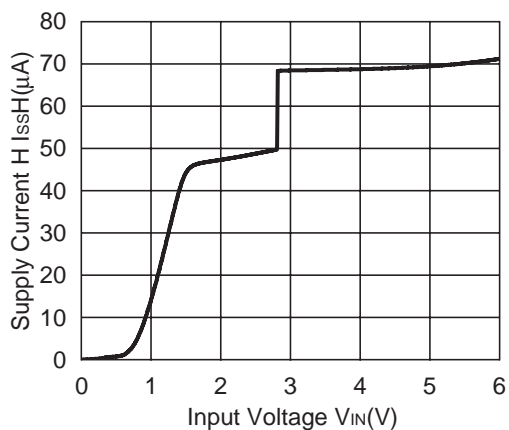

**R1163x281x ECO=L**

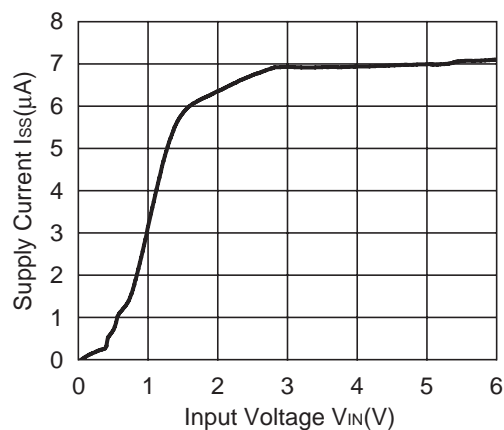

**R1163x401x ECO=H**

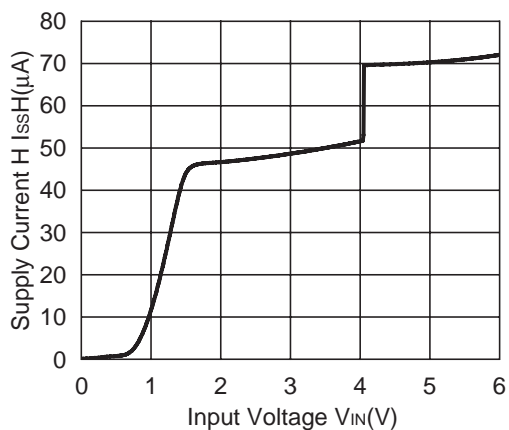

**R1163x401x ECO=L**

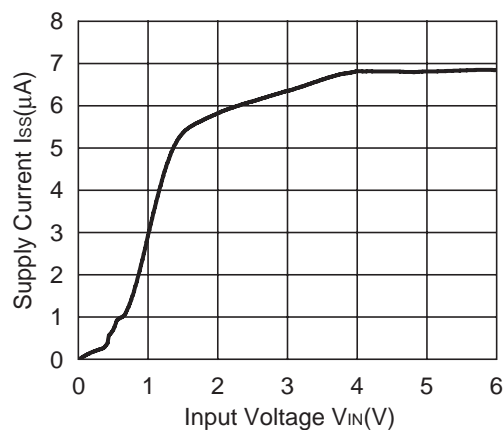

4) Output Voltage vs. Temperature

R1163x151x ECO=H

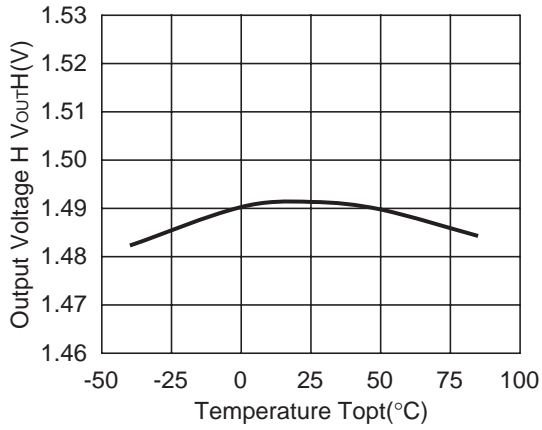

R1163x151x ECO=L

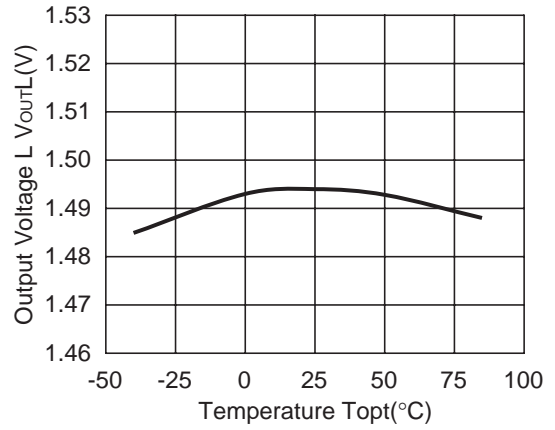

R1163x281x ECO=H

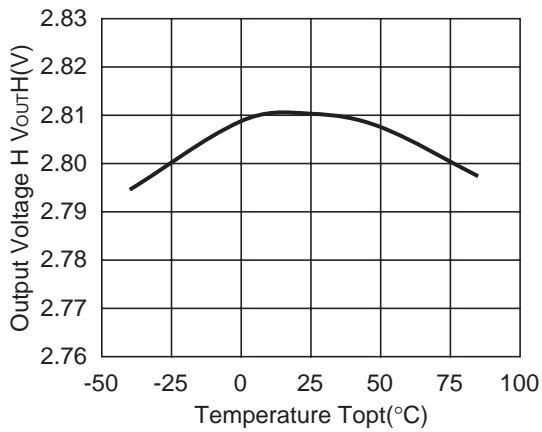

R1163x281x ECO=L

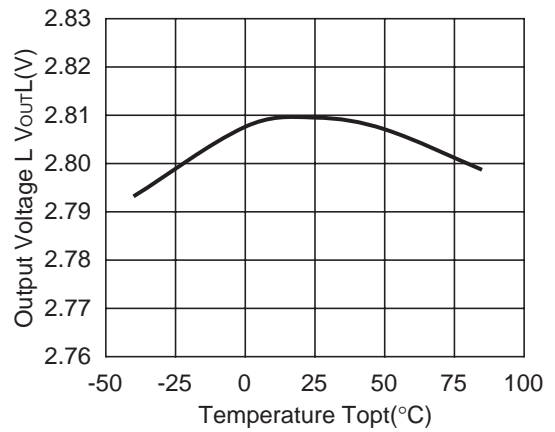

R1163x401x ECO=H

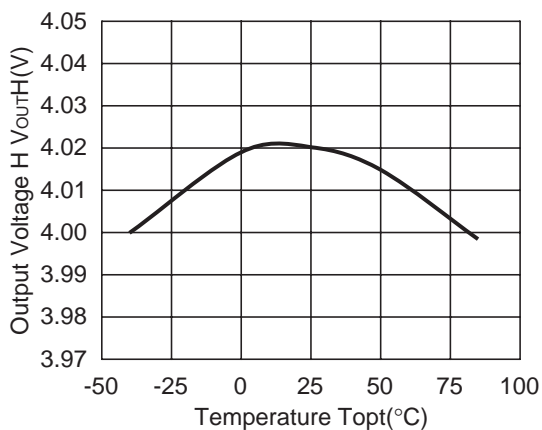

R1163x401x ECO=L

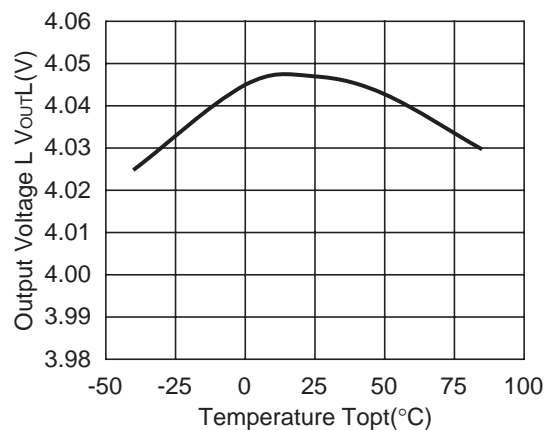

5) Supply Current vs. Temperature

R1163x151x ECO=H

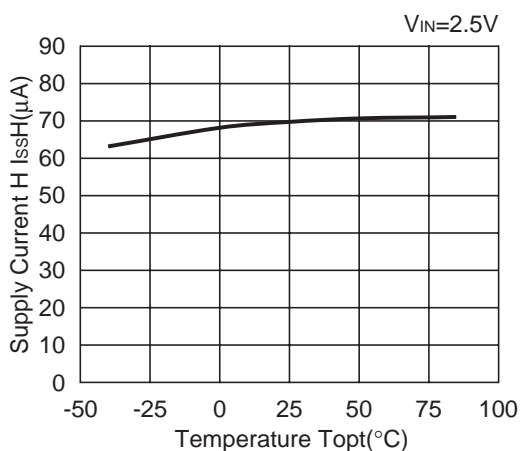

R1163x151x ECO=L

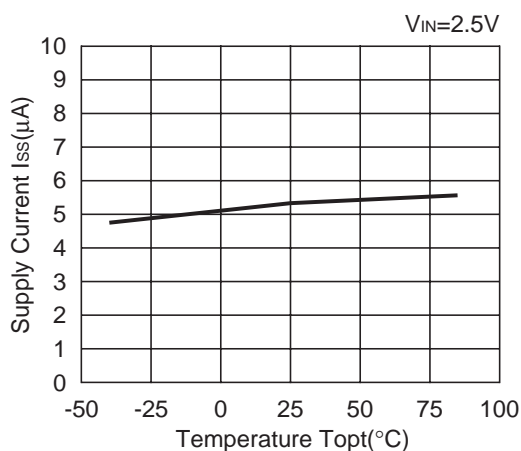

R1163x281x ECO=H

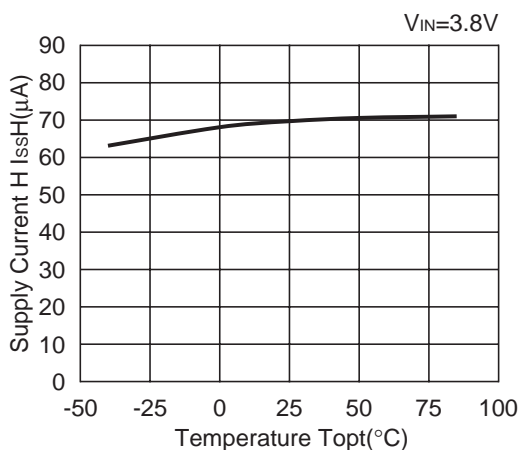

R1163x281x ECO=L

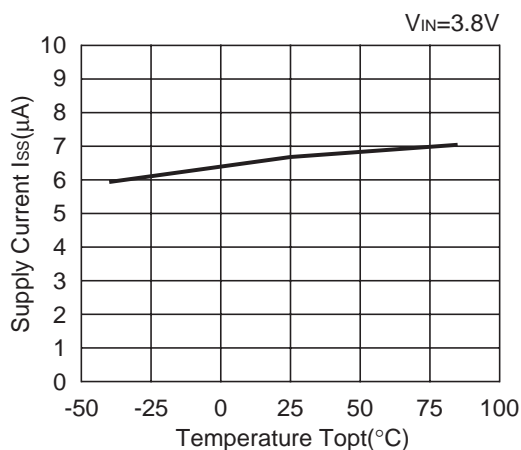

R1163x401x ECO=H

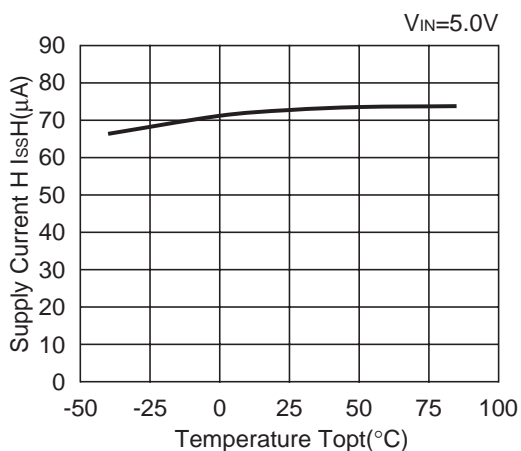

R1163x401x ECO=L

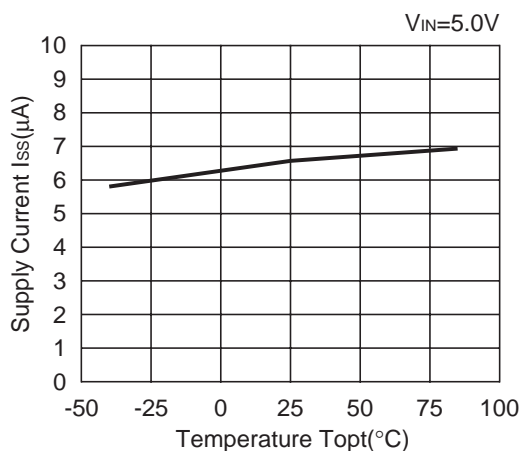

6) Standby Current vs. Input Voltage

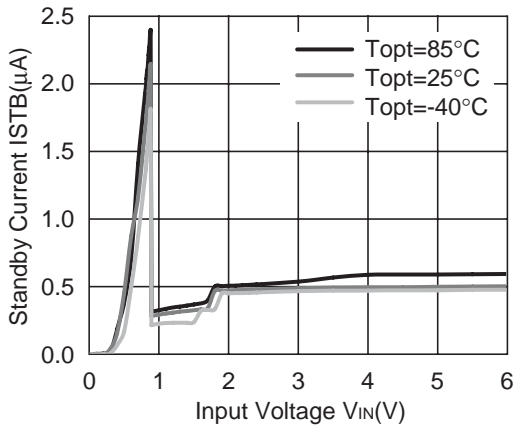

7) Reverse Current vs. Output Voltage

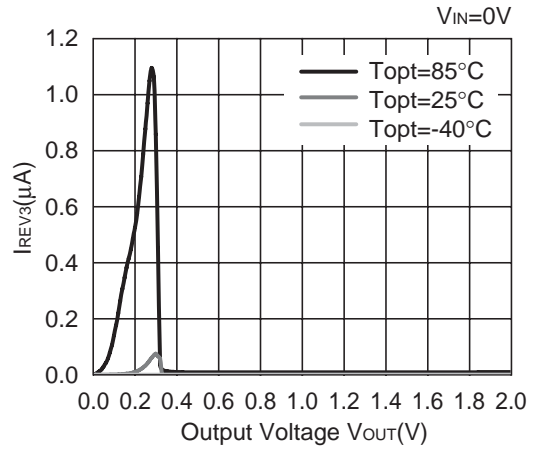
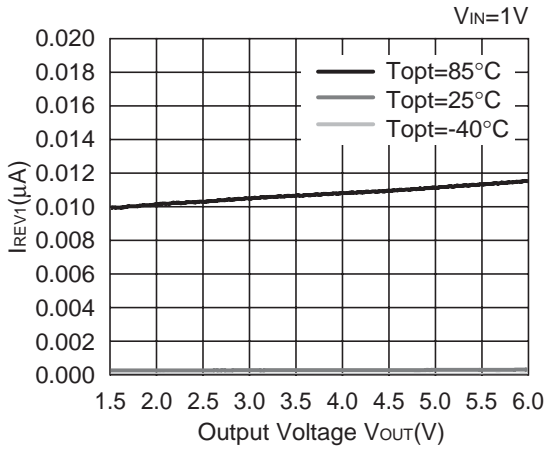

8) Dropout Voltage vs. Output Current

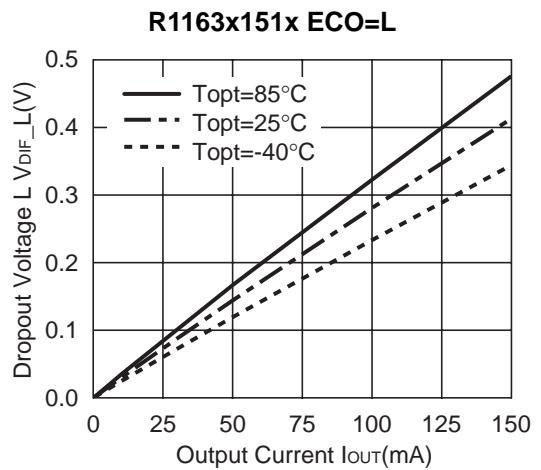
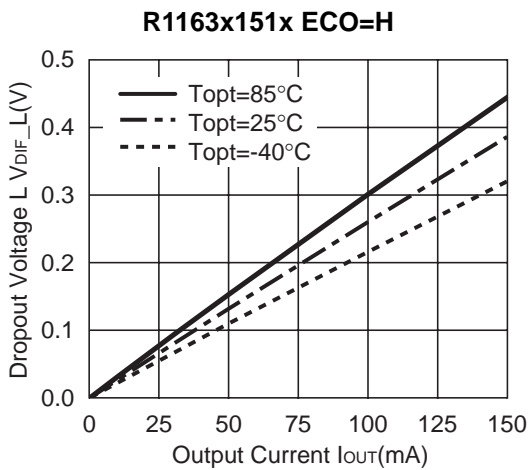



R1163x161x ECO=H

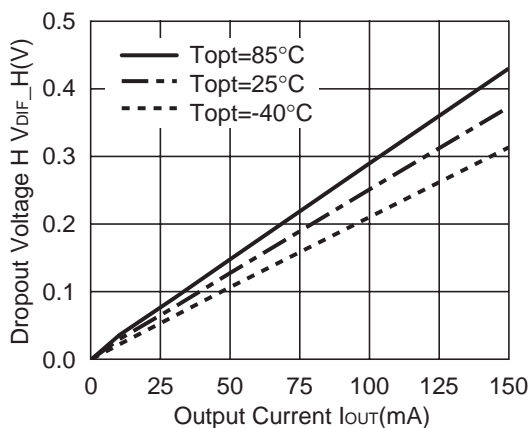

R1163x161x ECO=L

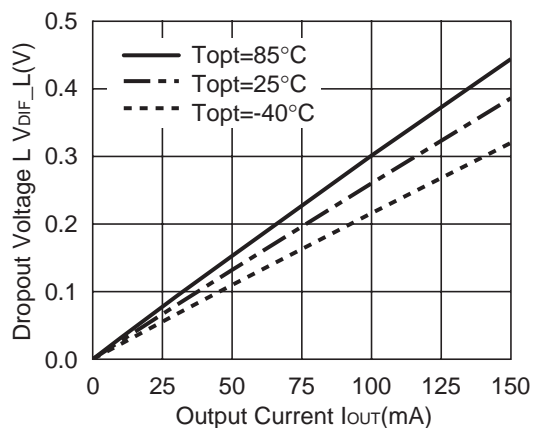

R1163x171x ECO=H

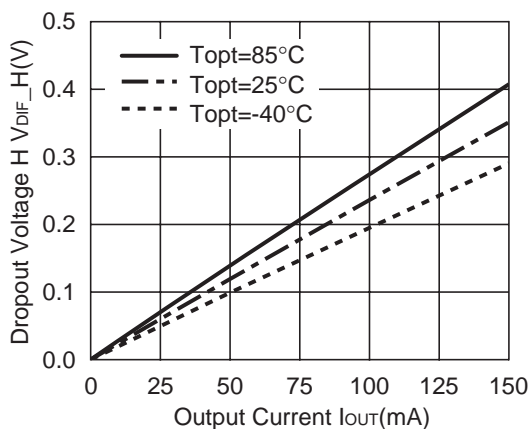

R1163x171x ECO=L

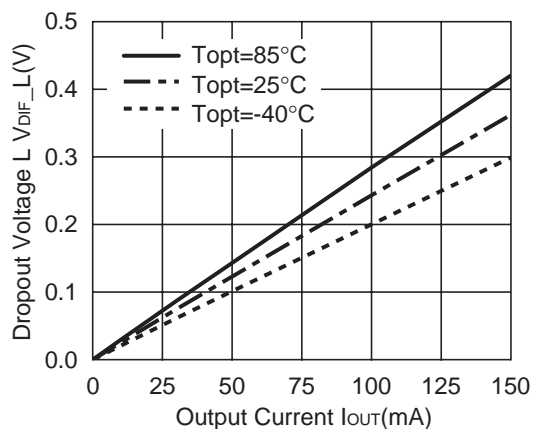

R1163x181x ECO=H

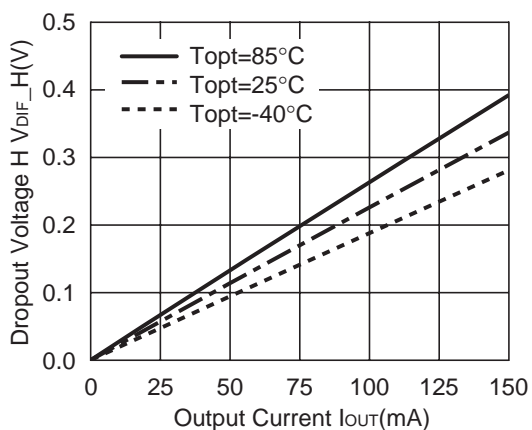

R1163x181x ECO=L

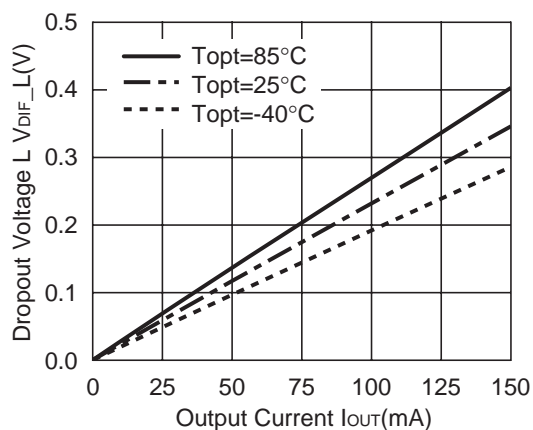

R1163x211x ECO=H

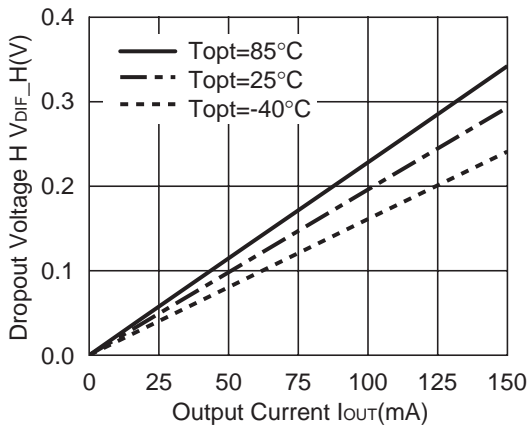

R1163x211x ECO=L

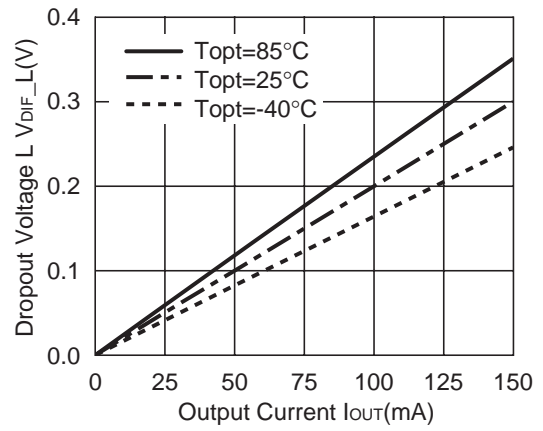

R1163x281x ECO=H

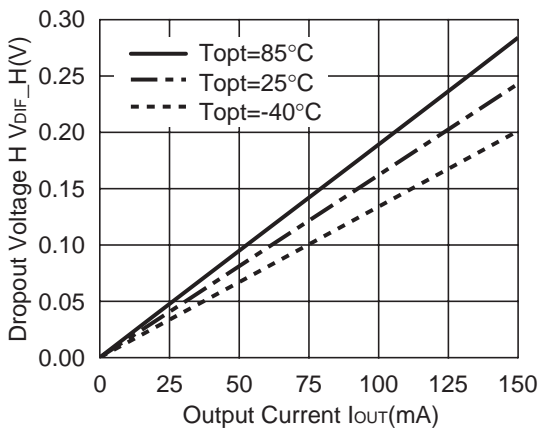

R1163x281x ECO=L

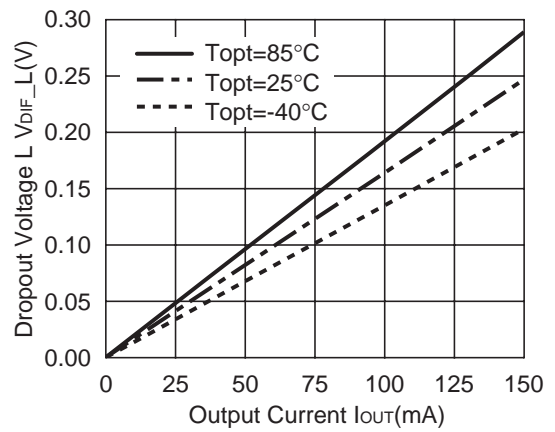

R1163x401x ECO=H

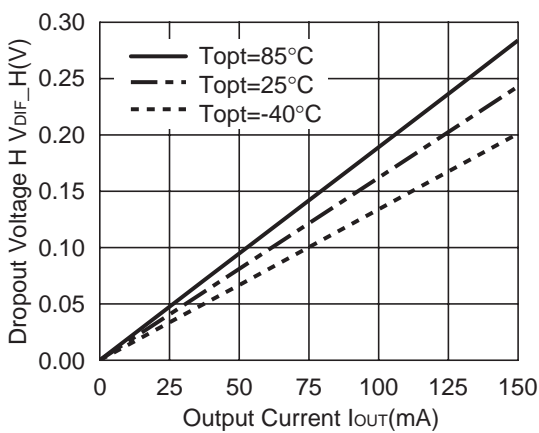

R1163x401x ECO=L

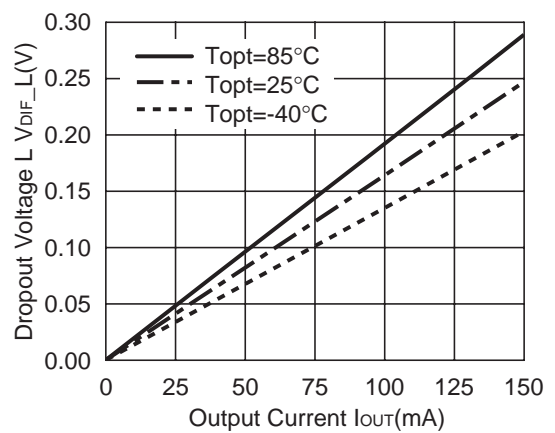

9) Dropout Voltage vs. Set Output Voltage

R1163x ECO=H

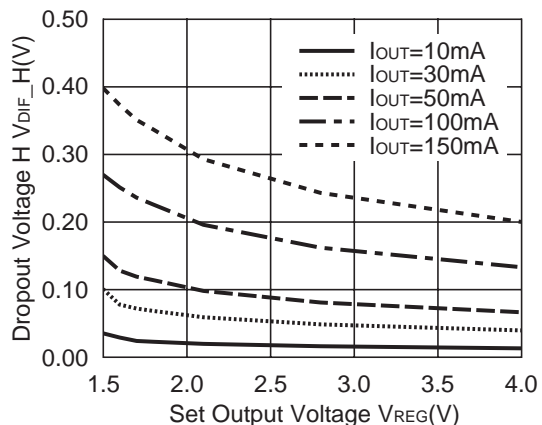

R1163x ECO=L

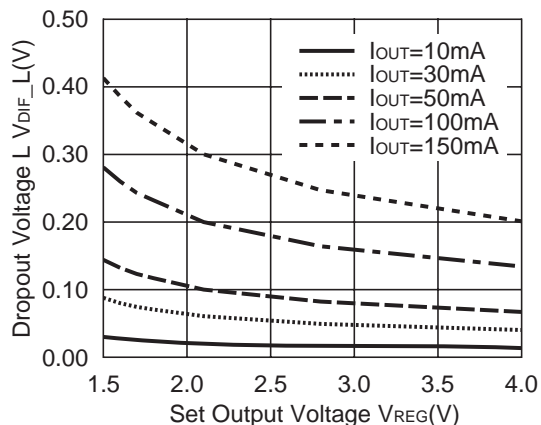

10) Ripple Rejection vs. Input Bias Voltage

R1163x281x ECO=H

C<sub>IN</sub>=none, C<sub>OUT</sub>=0.47μF,  
I<sub>OUT</sub>=1mA Ripple=0.2Vp-p

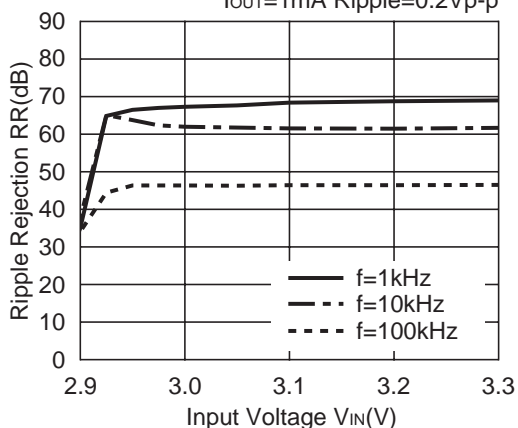

R1163x281x ECO=L

C<sub>IN</sub>=none, C<sub>OUT</sub>=0.47μF,  
I<sub>OUT</sub>=1mA Ripple=0.5Vp-p

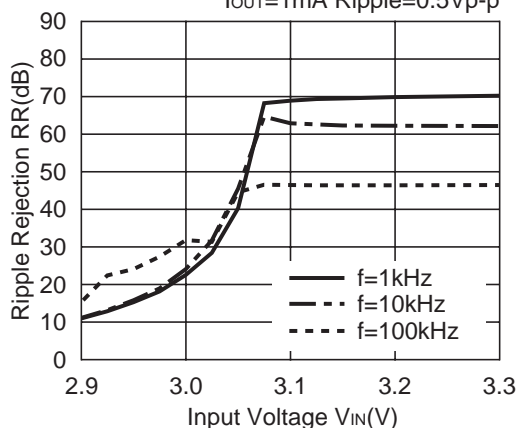

R1162x281x ECO=H

C<sub>IN</sub>=none, C<sub>OUT</sub>=0.47μF,  
I<sub>OUT</sub>=30mA Ripple=0.2Vp-p

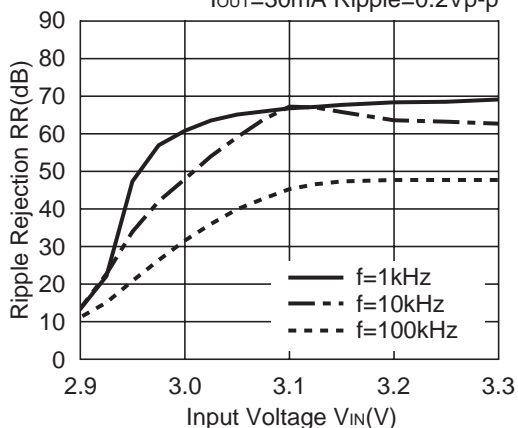

R1162x281x ECO=L

C<sub>IN</sub>=none, C<sub>OUT</sub>=0.47μF,  
I<sub>OUT</sub>=30mA Ripple=0.5Vp-p

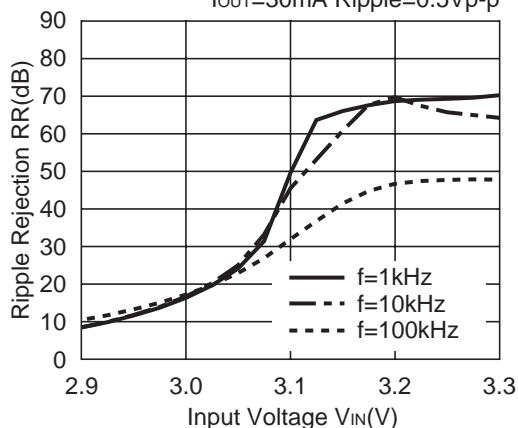

**R1163x281x ECO=H**

$C_{IN}$ =none,  $C_{OUT}$ =0.47 $\mu$ F,  
 $I_{OUT}$ =50mA Ripple=0.2Vp-p

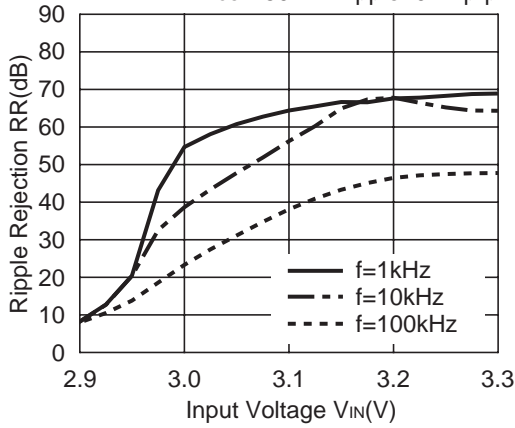

**R1163x281x ECO=H**

$C_{IN}$ =none,  $C_{OUT}$ =0.47 $\mu$ F,  
 $I_{OUT}$ =50mA Ripple=0.5Vp-p

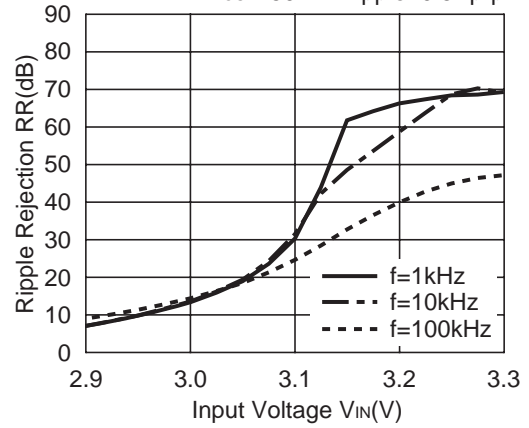

**11) Ripple Rejection vs. Frequency**

**R1163x151x ECO=H**

$C_{IN}$ =none,  $C_{OUT}$ =0.47 $\mu$ F,  
 $V_{IN}$ =2.5V<sub>DC</sub>+0.2Vp-p

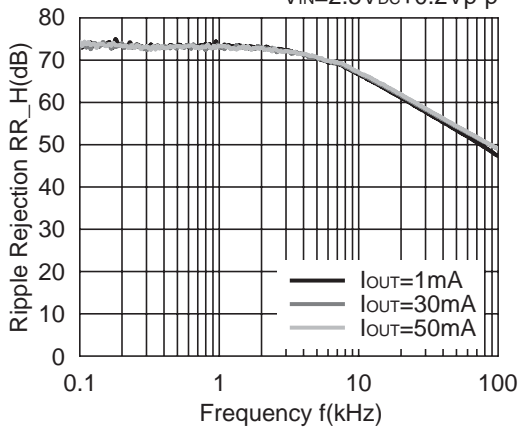

**R1163x151x ECO=L**

$C_{IN}$ =none,  $C_{OUT}$ =0.47 $\mu$ F,  
 $V_{IN}$ =2.5V<sub>DC</sub>+0.2Vp-p

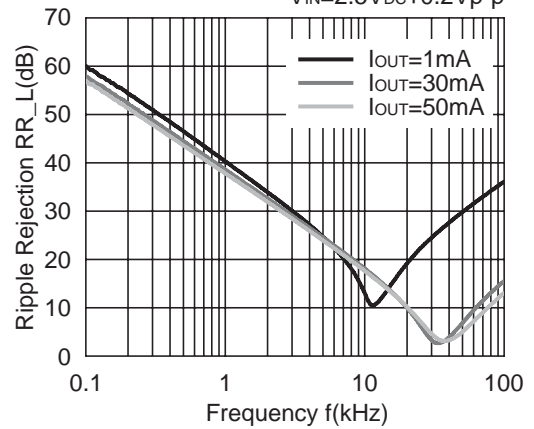

**R1163x281x ECO=H**

$C_{IN}$ =none,  $C_{OUT}$ =0.47 $\mu$ F,  
 $V_{IN}$ =3.8V<sub>DC</sub>+0.2Vp-p

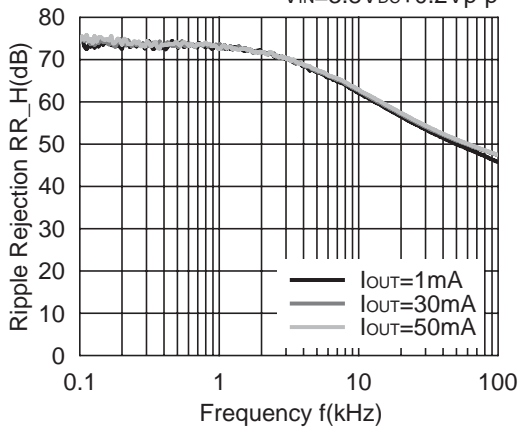

**R1163x281x ECO=L**

$C_{IN}$ =none,  $C_{OUT}$ =0.47 $\mu$ F,  
 $V_{IN}$ =3.8V<sub>DC</sub>+0.2Vp-p

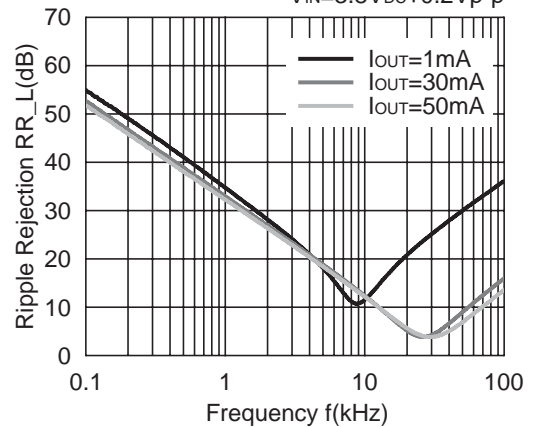

**R1163x401x ECO=H**

$C_{IN}$ =none,  $C_{OUT}$ =0.47 $\mu$ F,  
 $V_{IN}$ =5.0V<sub>DC</sub>+0.2V<sub>p-p</sub>

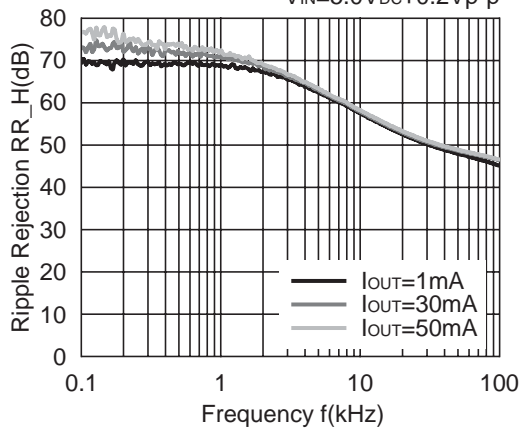

**R1163x401x ECO=L**

$C_{IN}$ =none,  $C_{OUT}$ =0.47 $\mu$ F,  
 $V_{IN}$ =5.0V<sub>DC</sub>+0.2V<sub>p-p</sub>

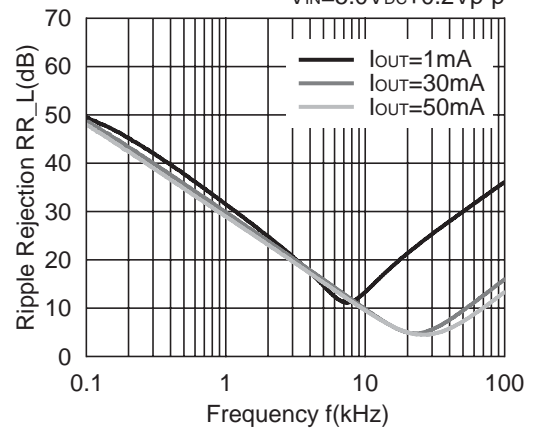

**12) Input Transient Response**

**R1163x151x ECO=H**

$C_{IN}$ =none,  $C_{OUT}$ =0.47 $\mu$ F  $I_{OUT}$ =30mA

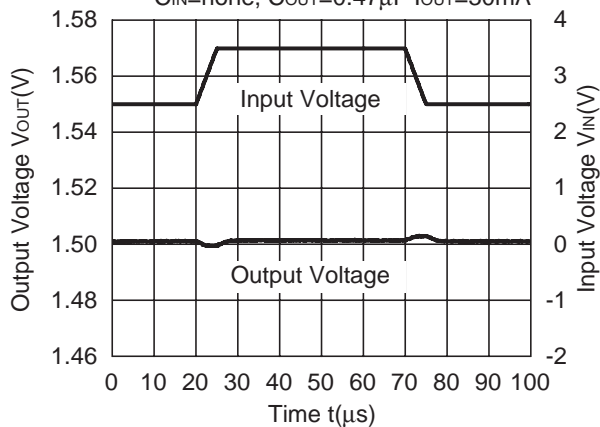

**R1163x151x ECO=L**

$C_{IN}$ =none,  $C_{OUT}$ =0.47 $\mu$ F  $I_{OUT}$ =10mA

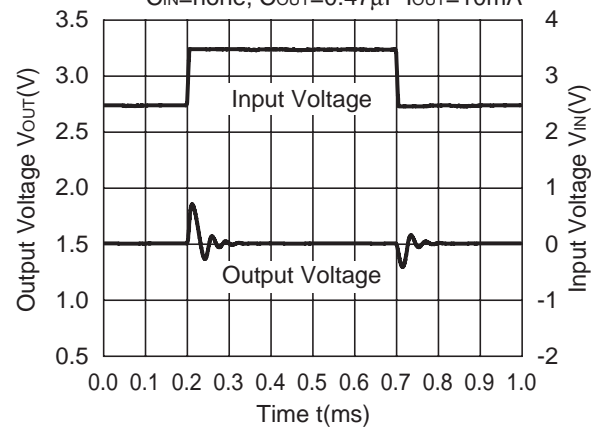

**R1163x151x ECO=L**

$C_{IN}$ =none,  $C_{OUT}$ =1 $\mu$ F  $I_{OUT}$ =10mA

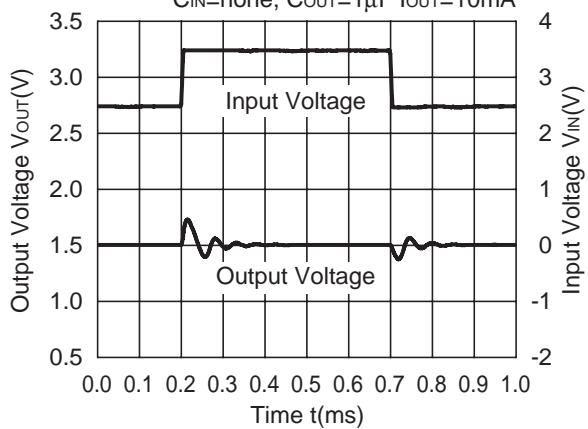

**R1163x281x ECO=H**

$C_{IN}$ =none,  $C_{OUT}$ =1 $\mu$ F  $I_{OUT}$ =30mA

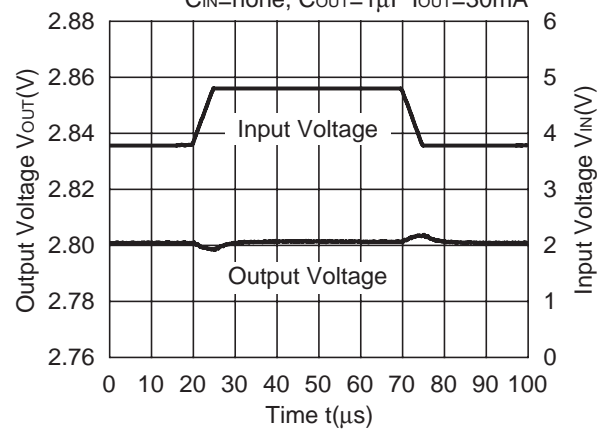

**R1163x281x ECO=H**

$C_{IN}=none, C_{OUT}=1\mu F, I_{OUT}=10mA$

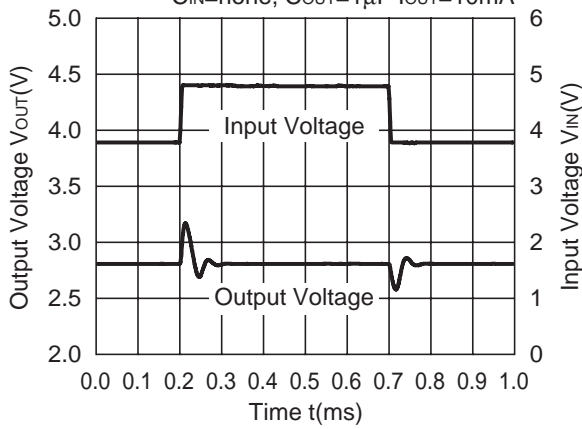

**13) Load Transient Response**

**R1163x151x ECO=H**

$V_{IN}=2.5V, C_{IN}=1\mu F, C_{OUT}=0.47\mu F$

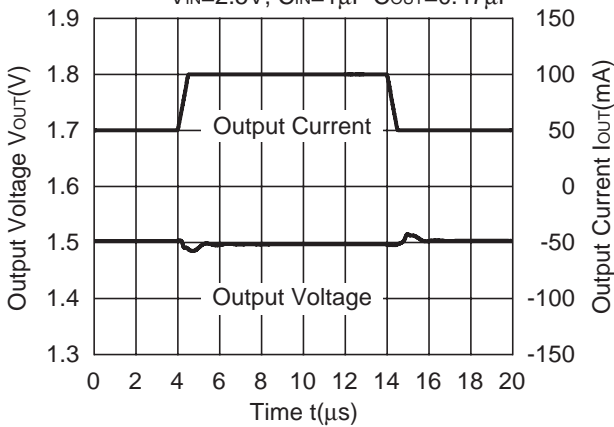

**R1163x151x ECO=H**

$V_{IN}=2.5V, C_{IN}=1\mu F, C_{OUT}=1.0\mu F$

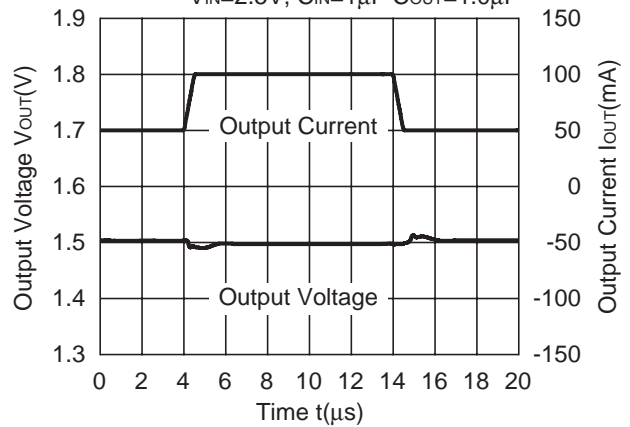

**R1163x151x ECO=H**

$V_{IN}=2.5V, C_{IN}=1\mu F, C_{OUT}=0.47\mu F$

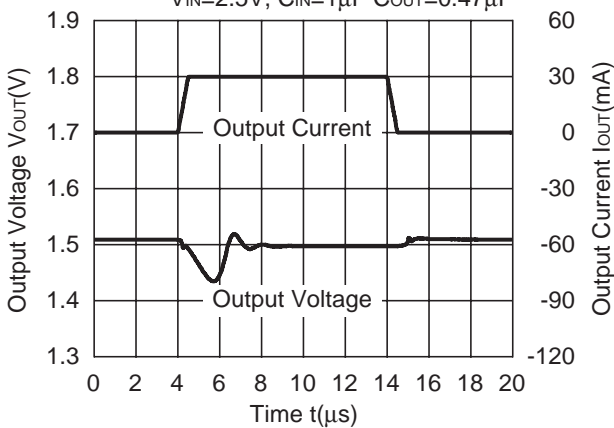

**R1163x151x ECO=H**

$V_{IN}=2.5V, C_{IN}=1\mu F, C_{OUT}=1.0\mu F$

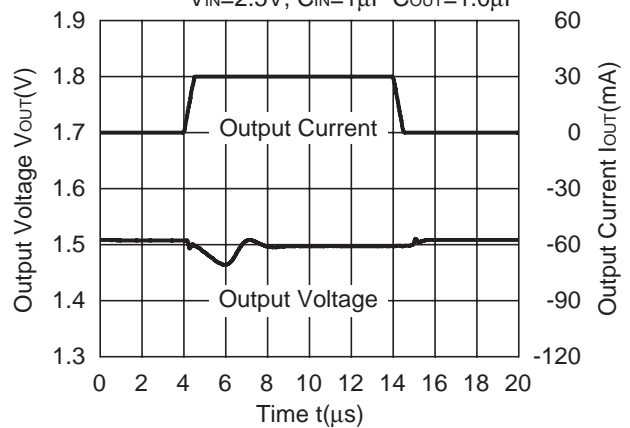

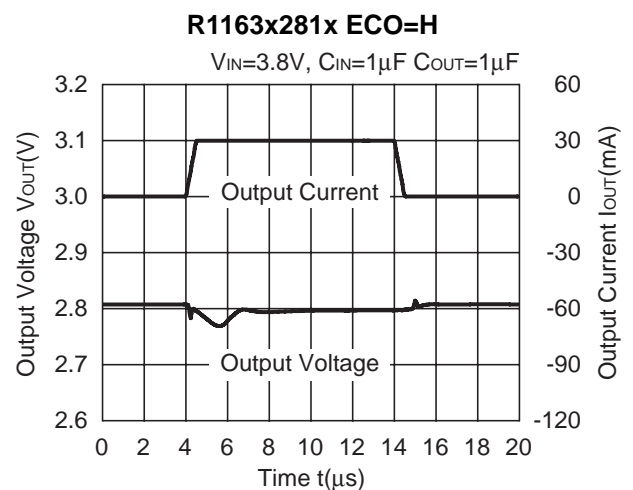
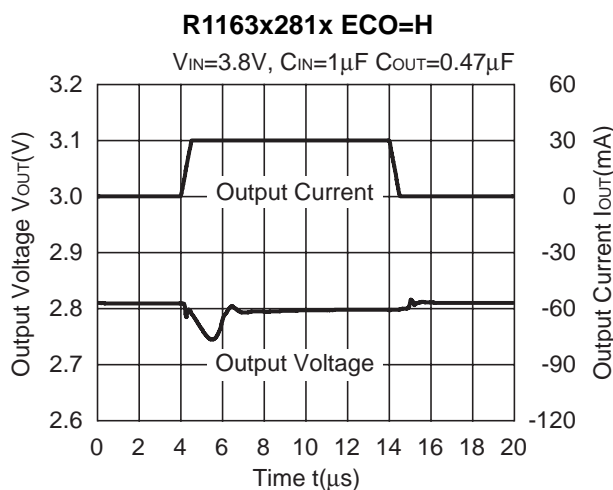
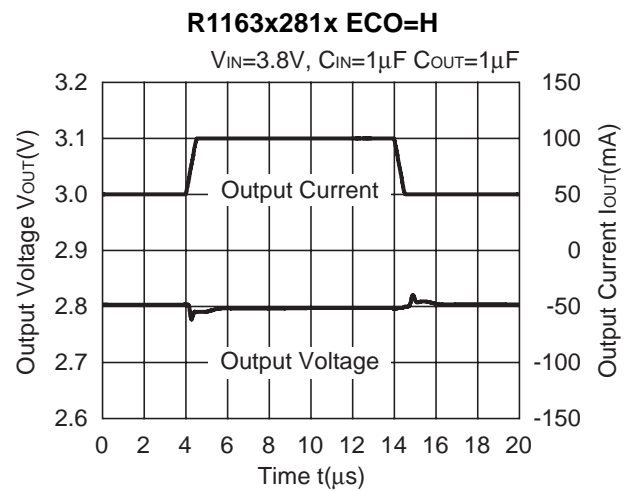
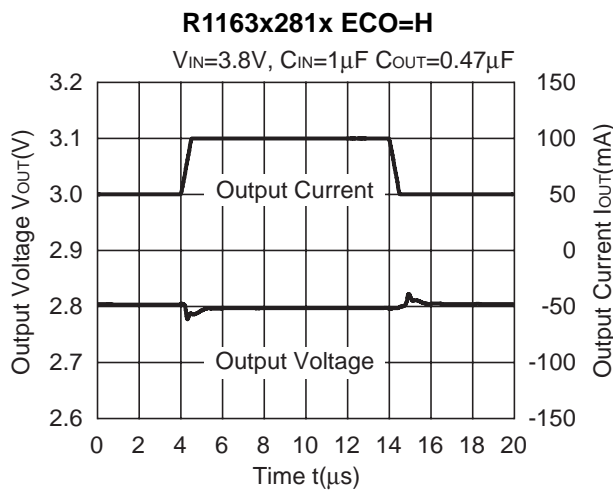
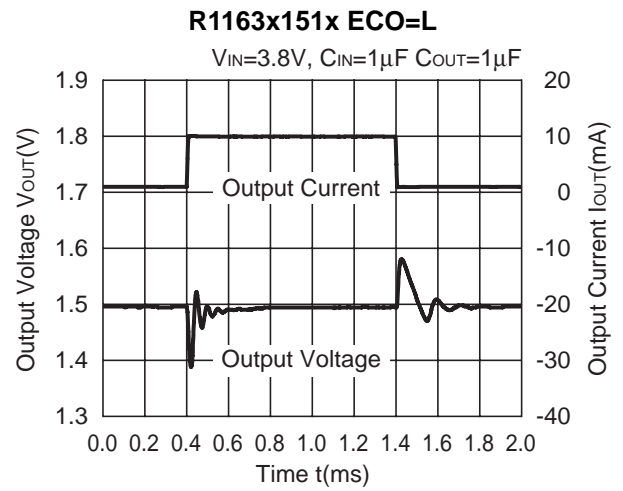
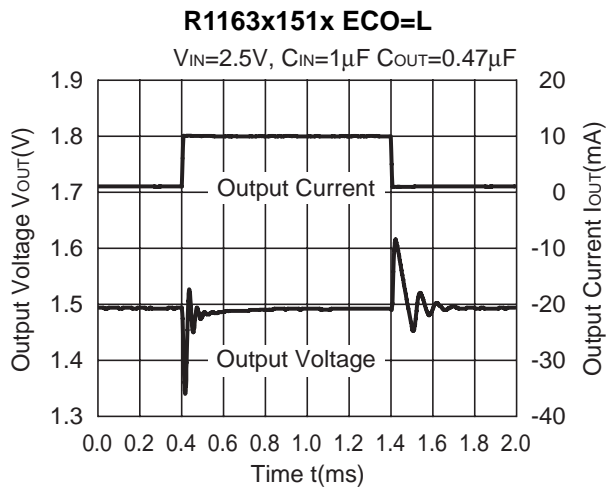

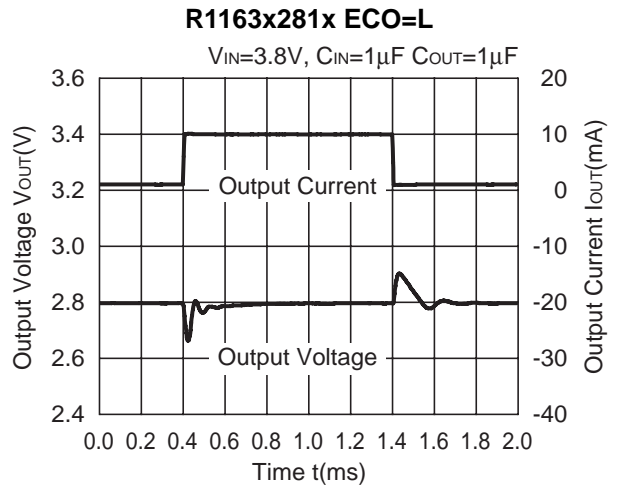
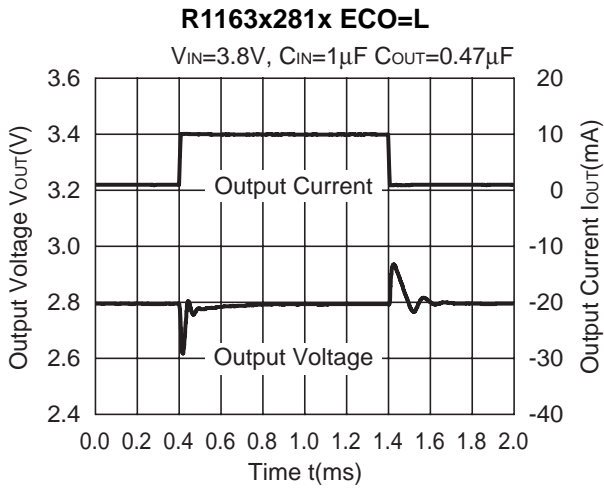

14) Turn on speed with CE pin

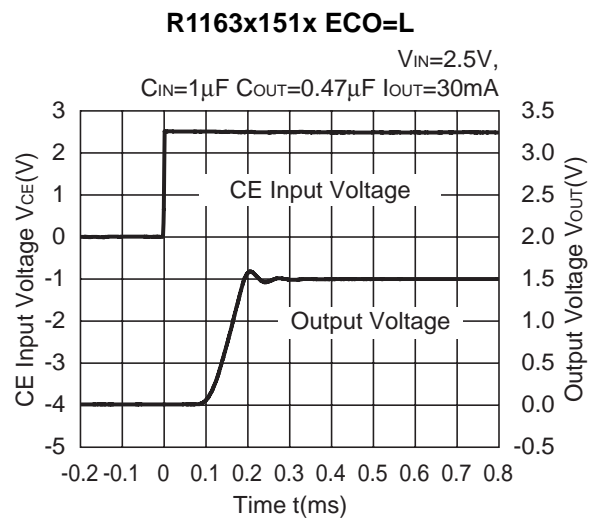
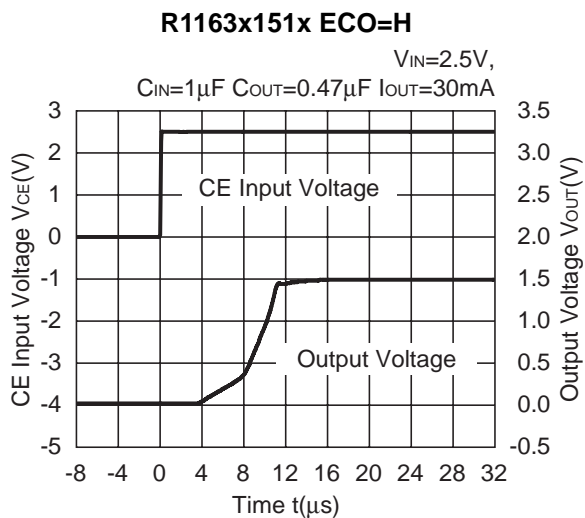
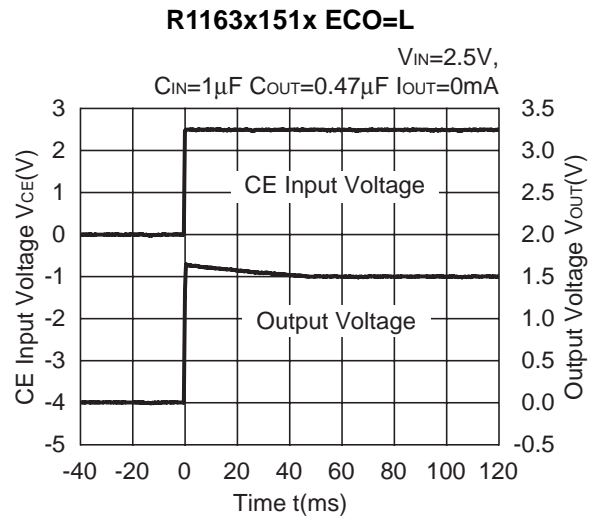
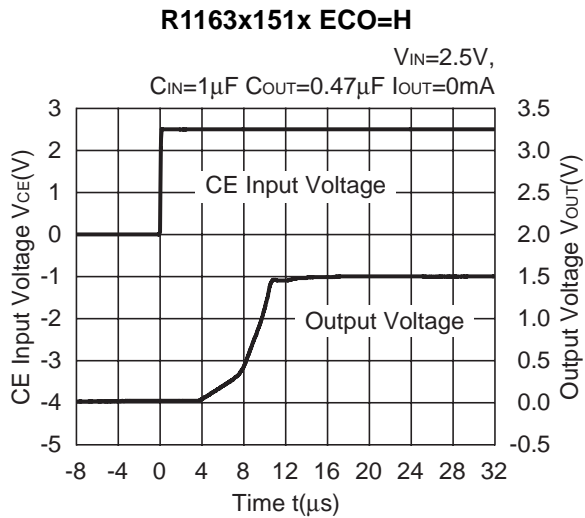



**R1163x151x ECO=H**

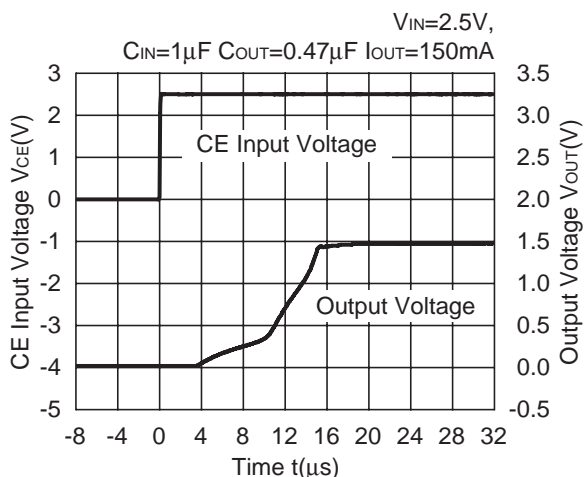

**R1163x151x ECO=L**

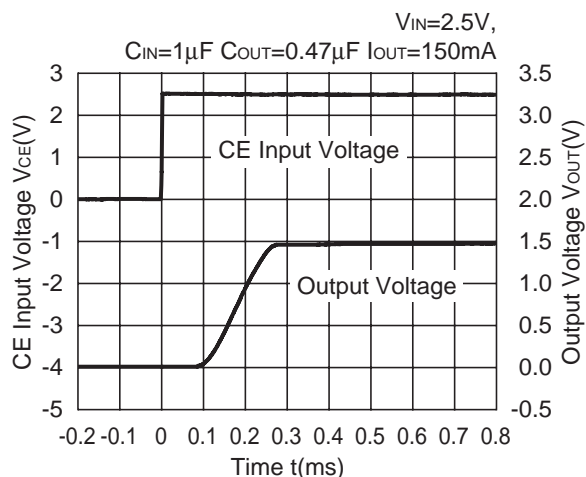

**R1163x281x ECO=H**

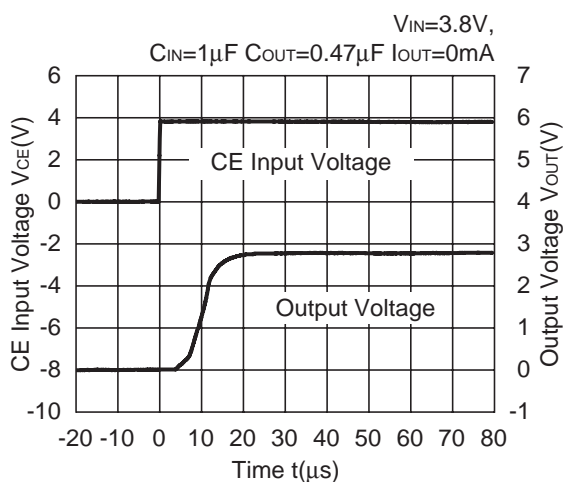

**R1163x281x ECO=L**

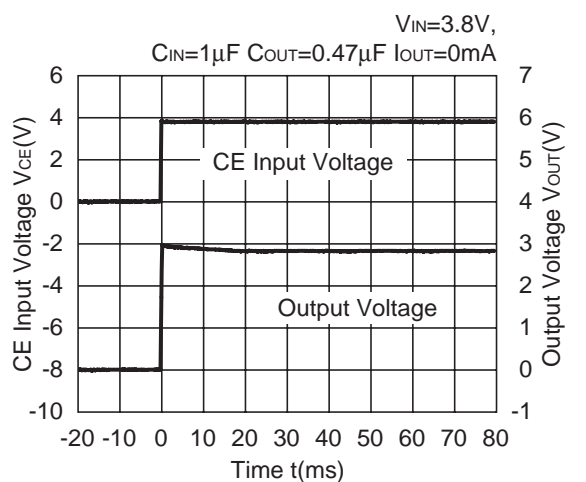

**R1163x281x ECO=H**

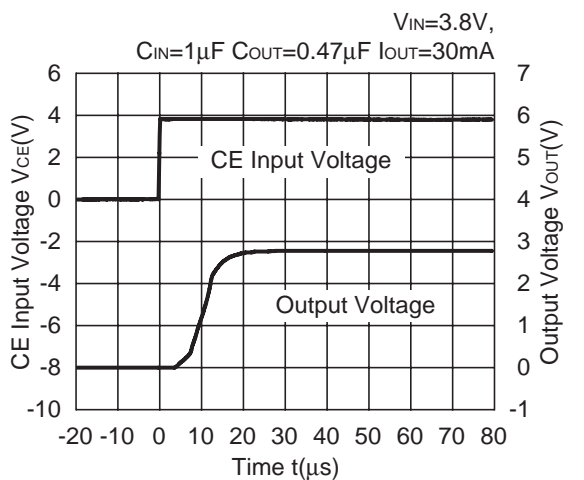

**R1163x281x ECO=L**

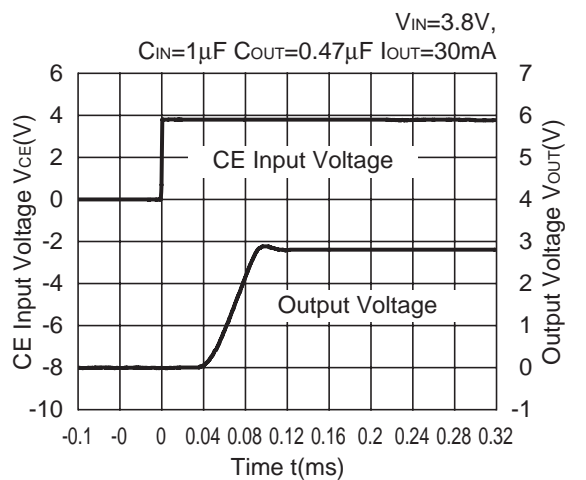

**R1163x281x ECO=H**

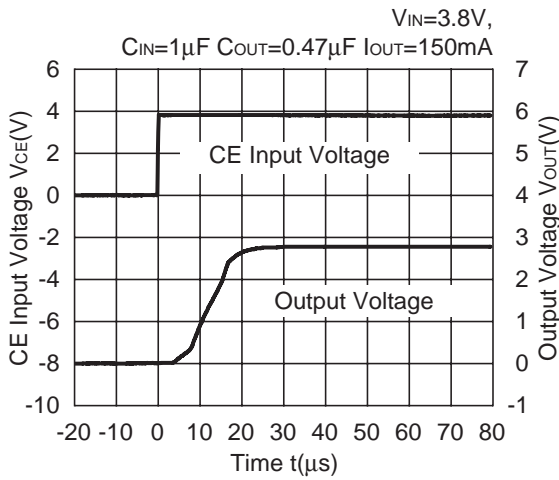

**R1163x281x ECO=L**

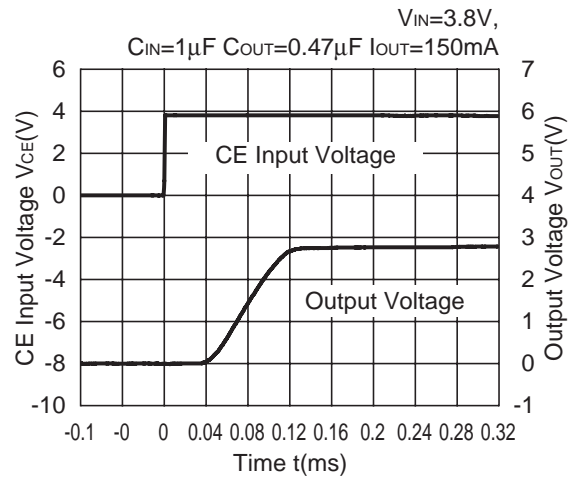

**R1163x401x ECO=H**

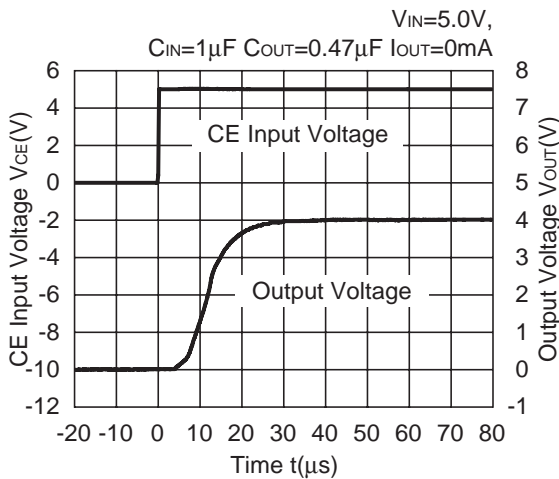

**R1163x401x ECO=L**

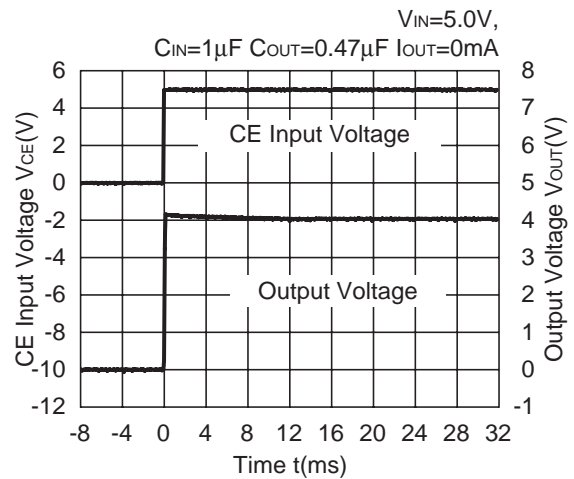

**R1163x401x ECO=H**

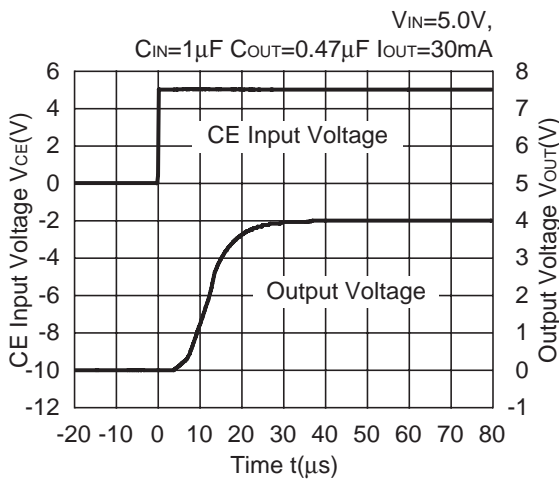

**R1163x401x ECO=L**

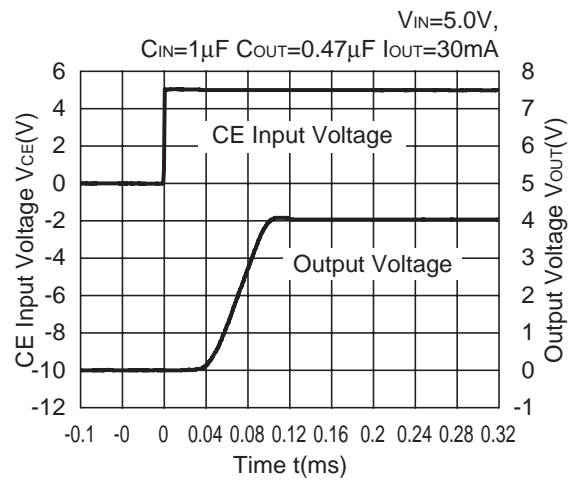

**R1163x401x ECO=H**

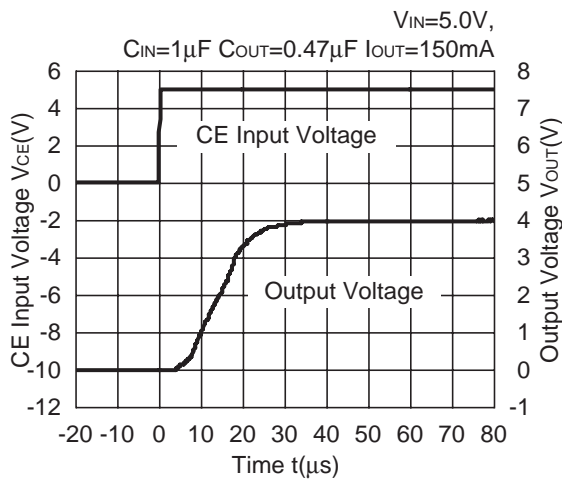

**R1163x401x ECO=L**

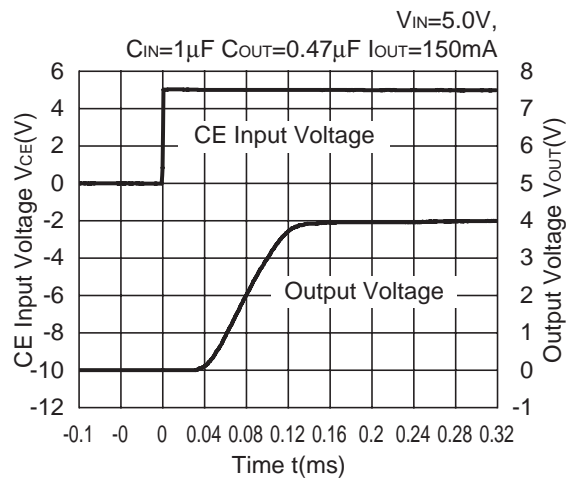

**15) Turn off speed with CE pin**

**R1163x151xD**

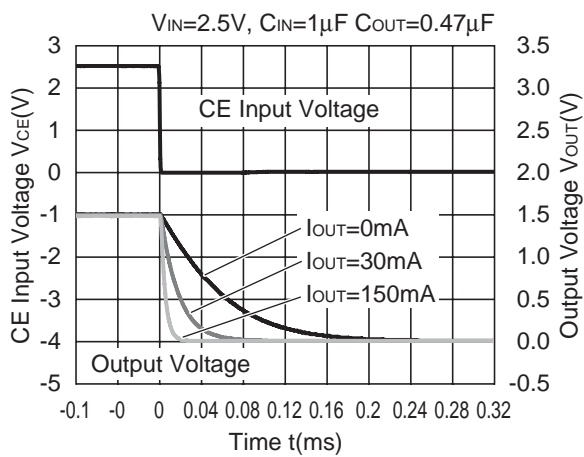

**R1163x281xD**

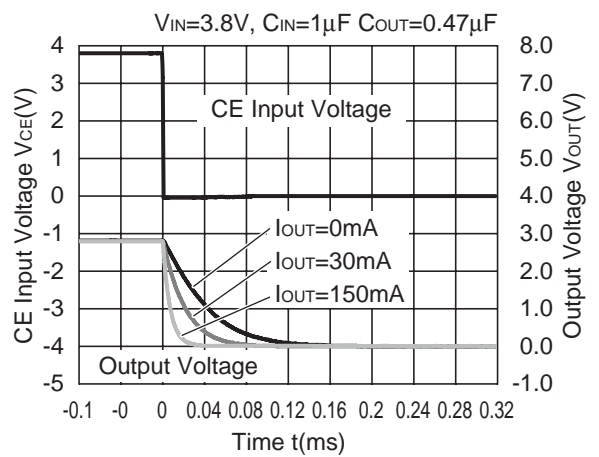

**R1163x401xD**

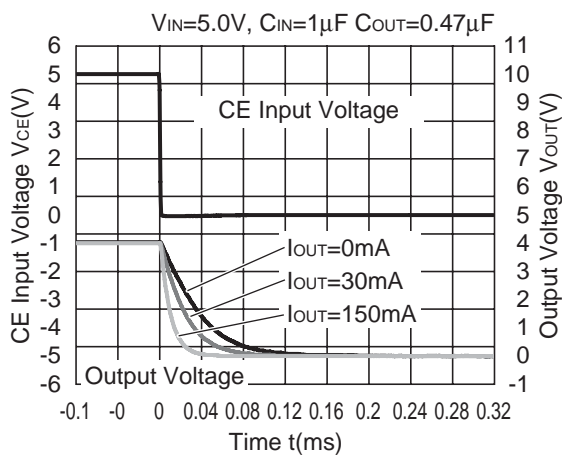

16) Output Voltage at Mode alternative point

R1163x151B/D

$V_{IN}=2.5V$ ,  $C_{IN}=\text{Ceramic } 1.0\mu F$ ,  
 $C_{OUT}=\text{Ceramic } 0.47\mu F$

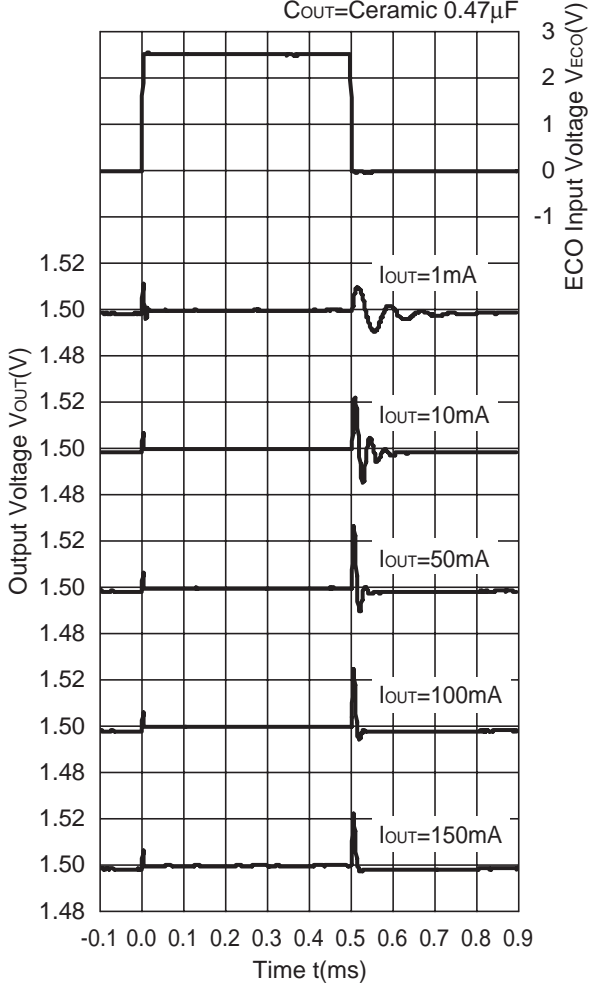

R1163x281B/D

$V_{IN}=3.8V$ ,  $C_{IN}=\text{Ceramic } 1.0\mu F$ ,  
 $C_{OUT}=\text{Ceramic } 0.47\mu F$

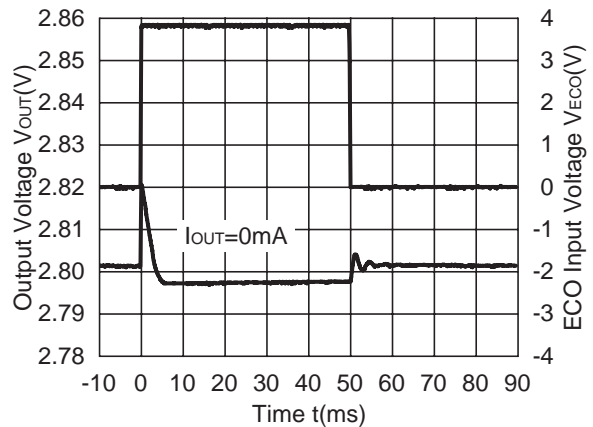
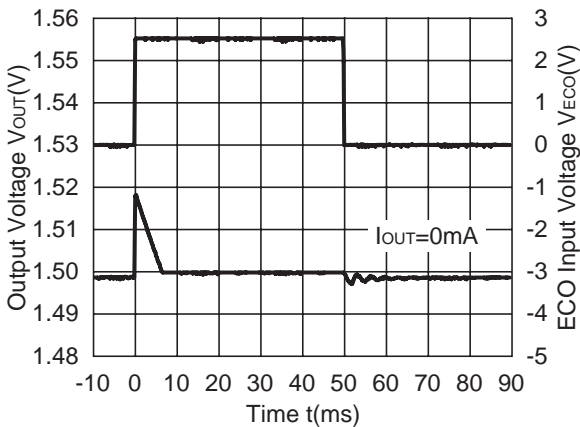
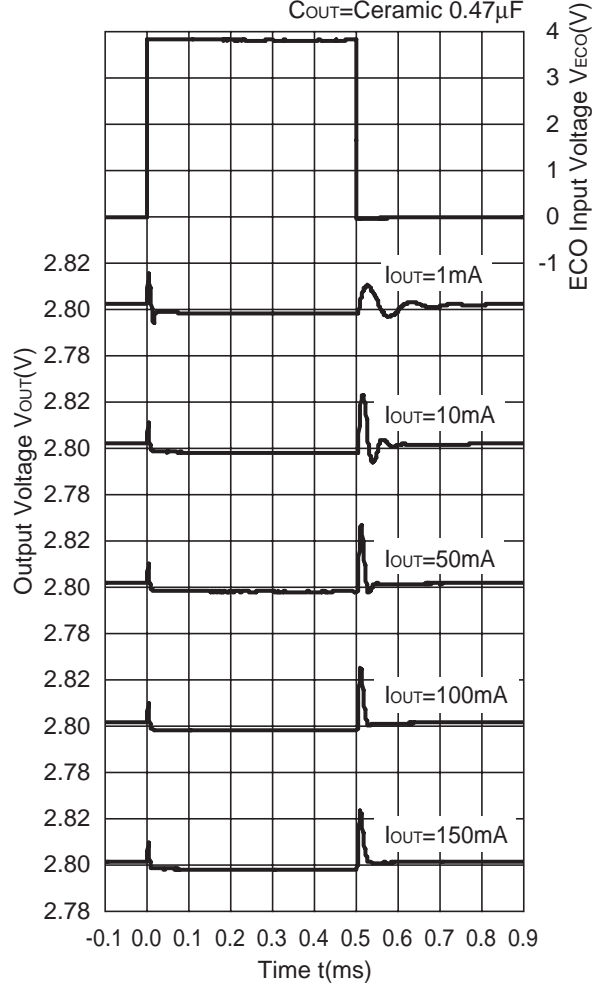

## TECHNICAL NOTES

When using these ICs, consider the following points:

In these ICs, phase compensation is made for securing stable operation even if the load current is varied. For this purpose, be sure to use a capacitor  $C_{OUT}$  with good frequency characteristics and ESR (Equivalent Series Resistance) in the range described as follows:

The relations between  $I_{OUT}$  (Output Current) and ESR of Output Capacitor are shown below. The conditions when the white noise level is under  $40\mu\text{V}$  (Avg.) are marked as the hatched area in the graph.

### <Test conditions>

#### (1) Frequency band: 10Hz to 2MHz

