

The latest addition to the ITT Cannon Snap-Lock Environmental series, the Snap-Lock Circular, features high density, small contacts and rapid installation.

## How to Order

SLC - \* \* \* - \* \*

SERIES PREFIX \_\_\_\_\_

SIZE/CONFIGURATION \_\_\_\_\_

CONNECTOR TYPE \_\_\_\_\_

CONTACT TERMINATION \_\_\_\_\_

MATERIAL/FINISH MODIFIER \_\_\_\_\_

MECHANICAL MODIFIER \_\_\_\_\_

**SERIES PREFIX**  
SLC – Snap-Lock Circular

**SIZE/CONFIGURATION**  
5 – 5 Cavity Housing  
10 – 10 Cavity Housing

**CONNECTOR TYPE**  
R – In-line Rcpt. (Cable)  
B – P.C.B. Rcpt.  
P – Plug (Cable)  
T – Snap-thru Rcpt.

**CONTACT TERMINATION**  
A – Pin, Crimp 5 Amp } (Rcpt. only – stamped)  
B – Pin, Crimp 13 Amp }  
C – Skt, Crimp 5 Amp } (Plug only – stamped)  
D – Skt, Crimp 13 Amp }  
E – P.C.B., Pin, 5 Amp } (Rcpt. only)  
F – P.C.B., Pin, 13 Amp }

**MATERIAL/FINISH MODIFIER**  
0 – Standard Assembly

**MECHANICAL MODIFIER**  
0 – Standard Assembly

NOTE: Assemblies are supplied "Less" contacts (except Type "B" connector)

## Standard Data

### MECHANICAL DATA

Crimp Contacts	Semi-automatic or hand-insertable (Pin for receptacle/Socket for plug)
Wire Size	#16, #18, #20 AWG
Wire Insulation Sealing Range	.095 (2.41) to .130 (3.30) dia.
Contact Insertion	No tool required, suitable for automation
Contact Extraction	Rear removable with approved tool
Contact Retention	10 lbs.
Wire Strip Length (Crimp Contacts)	.210 (5.33) to .220 (5.59)

### ELECTRICAL DATA

Contact Resistance	10 milliohms max.
Insulation Resistance	100 megohms min.
Current Rating	5 or 13 amps
Operating Temperature	-40° to +125°C
Applicable ITT Cannon Specification	CS-206

### MATERIAL AND FINISHES

Item	Material/Finish
Plug & Receptacle Assemblies	High Temperature Thermoplastic Housing with Silicone Elastomer Sealing
Contacts Pin & Socket	
Material:	Copper Alloy
Finish:	Engaging Area: gold over nickel Crimp/P.C. Tail Area: Tin/Lead over nickel

## Contact Arrangements

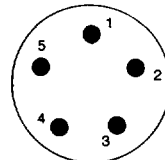

SLC-5  
Face view,  
plug side

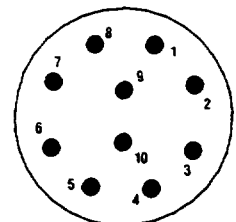

SLC-10  
Face view,  
plug side

## Test Parameters

SLC products are designed to meet ITT Cannon specification CS-206. Items of most general interest to users and designers are listed below.

Test Description	Reference Paragraph	Requirements																																							
<b>Environmental Sealing</b>	3.2.3.5 3.2.3.6 3.2.3.7 3.2.3.8 3.2.3.9 3.2.3.2	Sand and Dust MIL-STD-202 Method 110 Test Condition A 5% salt spray 96 hours 10 cycles of 24 hours, 90-98% humidity Steam Cleaning/Pressure Wash 95°C, 375 Cycles 750 PSIG Solvent Resistance/Immersion (see 3.2.3.9) Thermal Shock 100 Cycles -40°C to +125°C ± 3°C																																							
<b>Contact Crimp Tensile Strength</b>	3.2.2.1	The minimum tensile load required to separate the wire from the contact, either by pulling the wire out of the crimp joint or breaking the wire within the crimp joint shall not be less than the applicable limits as specified. Wire breakage or contact damage not due to crimping at less than tensile loads shall not constitute a failure. <table border="1" style="margin-left: 40px;"> <thead> <tr> <th>Wire Size SWG</th> <th>Crimp Tensile Strength, Pounds Minimum</th> </tr> </thead> <tbody> <tr> <td>16</td> <td>35</td> </tr> <tr> <td>18</td> <td>25</td> </tr> <tr> <td>20</td> <td>20</td> </tr> </tbody> </table>	Wire Size SWG	Crimp Tensile Strength, Pounds Minimum	16	35	18	25	20	20																															
Wire Size SWG	Crimp Tensile Strength, Pounds Minimum																																								
16	35																																								
18	25																																								
20	20																																								
<b>Insulation Resistance</b>	3.2.1.1	Mated and wired connectors shall exhibit an insulation resistance greater than 100 megohms between all contacts. This limit shall apply after exposure to each environment including salt solution immersion. Tests shall be performed at 100 VDC ± 10%.																																							
<b>Dielectric Withstanding Voltage</b>	3.2.1.2	Wired and mated connectors shall show no evidence of breakdown between adjacent contacts when tested at 1000 VDC ± 5%. Connectors shall meet this requirement after exposure to each environment. Current leakage shall be less than 1.0 milliamp.																																							
<b>Low Level Contact Resistance</b>	3.2.1.4	The low level contact resistance of mated contacts shall be less than 10 milliohms when measured across the contacts and crimp joints. The test current shall be a maximum of 100 milliamps with an open circuit test voltage of 20 millivolts maximum.																																							
<b>Mechanical Shock</b>	3.2.3.3	Connectors shall be subjected to three shocks in each direction applied along the three mutually perpendicular axes of the connector test specimen for a total of 12 shocks. Each shock shall consist of a terminal peak sawtooth pulse with a peak value of 100 g's and a duration of 6 milliseconds.																																							
<b>Vibration</b>	3.2.3.4	Connectors shall be subjected to random vibration in accordance with MIL-STD-1344, Method 2005.1, test condition VI, for 20 hours along each of the following three axes: <table border="1" style="margin-left: 40px;"> <thead> <tr> <th>Direction</th> <th>Grms</th> </tr> </thead> <tbody> <tr> <td>Radial axis of connector (Y)</td> <td>10.2</td> </tr> <tr> <td>Longitudinal axis of connector (Z)</td> <td>10.2</td> </tr> </tbody> </table> Electrical continuity of the connectors shall be monitored during the last 20 minute sweep in each axis with a test current of 100 milliamps or less and a test voltage less than 2 VDC. Electrical discontinuities in excess of 10 microseconds shall be cause of failure.	Direction	Grms	Radial axis of connector (Y)	10.2	Longitudinal axis of connector (Z)	10.2																																	
Direction	Grms																																								
Radial axis of connector (Y)	10.2																																								
Longitudinal axis of connector (Z)	10.2																																								
<b>Durability</b>	3.2.2.6	Connectors shall be subjected to 25 cycles of mating and unmating at room temperature. Following this test there shall be no evidence of damage to the contacts, contact plating, connector housing or seals which may prove detrimental to reliable performance of the connector.																																							
<b>Contact</b>	3.2.2.2	Contacts shall not be displaced greater than 0.030 inches from the connector body when a force of 10 pounds is applied. When this test follows maintenance aging the same contacts shall be tested.																																							
<b>Maintenance Aging</b>	3.2.2.3	Consist of subjecting each wired receptacle to 5 cycles of removal and reinsertion of 20% of the contacts or a minimum of 5 per connector with approved tooling.																																							
<b>Mating and Separating Force</b>	3.2.2.4	The maximum force required to mate the plug and receptacle shall be 10 pounds. The maximum force required to separate the plug and receptacle shall be 5 pounds. The rate of travel shall be one inch per minute.																																							
<b>Solvent Resistance Immersion</b>	3.2.3.9	Connectors shall be subjected to the following fluids at the temperature and length of time specified. Following the fluid dip or immersion, the connectors shall be immersed to a depth of 2 to 12 inches in a 5% salt water solution for 24 hours at room temperature. At the completion of the salt water immersion test, while still immersed, the connectors shall meet the insulation resistance requirement specified herein. <table border="1" style="margin-left: 40px;"> <thead> <tr> <th>Fluid</th> <th>Method</th> <th>Temperature</th> </tr> </thead> <tbody> <tr> <td>No. 2 Diesel Fluid</td> <td>Immersion (2)</td> <td>140°F</td> </tr> <tr> <td>Methyl Alcohol</td> <td>Dip (1)</td> <td>Room Temperature</td> </tr> <tr> <td>Antifreeze</td> <td></td> <td></td> </tr> <tr> <td>—Prestone</td> <td>Immersion (2)</td> <td>180°F</td> </tr> <tr> <td>—50% Water/50% Ethylene Glycol</td> <td>Immersion (2)</td> <td>180°F</td> </tr> <tr> <td>Degreaser</td> <td></td> <td></td> </tr> <tr> <td>—Gunk</td> <td>Dip (1)</td> <td>Room Temperature</td> </tr> <tr> <td>—Mineral Spirits</td> <td>Dip (1)</td> <td>Room Temperature</td> </tr> <tr> <td>Paint (Oil Base)</td> <td>Immersion (2)</td> <td>Room Temperature</td> </tr> <tr> <td>Lubricating Oil (SAE 10 W40)</td> <td>Immersion (2)</td> <td>200°F</td> </tr> <tr> <td>Brake Fluid (Delco Supreme)</td> <td>Dip (1)</td> <td>Room Temperature</td> </tr> <tr> <td>Transmission Fluid – fully submerged and pressurized @ 7 psi. (Dextron)</td> <td>Dip (1)</td> <td>Room Temperature</td> </tr> </tbody> </table> (1) Dip: Connectors shall withstand a one second dip and a three minute air dry for a total of 80 cycles. (2) Immersion: Connectors shall withstand immersion for one hour.	Fluid	Method	Temperature	No. 2 Diesel Fluid	Immersion (2)	140°F	Methyl Alcohol	Dip (1)	Room Temperature	Antifreeze			—Prestone	Immersion (2)	180°F	—50% Water/50% Ethylene Glycol	Immersion (2)	180°F	Degreaser			—Gunk	Dip (1)	Room Temperature	—Mineral Spirits	Dip (1)	Room Temperature	Paint (Oil Base)	Immersion (2)	Room Temperature	Lubricating Oil (SAE 10 W40)	Immersion (2)	200°F	Brake Fluid (Delco Supreme)	Dip (1)	Room Temperature	Transmission Fluid – fully submerged and pressurized @ 7 psi. (Dextron)	Dip (1)	Room Temperature
Fluid	Method	Temperature																																							
No. 2 Diesel Fluid	Immersion (2)	140°F																																							
Methyl Alcohol	Dip (1)	Room Temperature																																							
Antifreeze																																									
—Prestone	Immersion (2)	180°F																																							
—50% Water/50% Ethylene Glycol	Immersion (2)	180°F																																							
Degreaser																																									
—Gunk	Dip (1)	Room Temperature																																							
—Mineral Spirits	Dip (1)	Room Temperature																																							
Paint (Oil Base)	Immersion (2)	Room Temperature																																							
Lubricating Oil (SAE 10 W40)	Immersion (2)	200°F																																							
Brake Fluid (Delco Supreme)	Dip (1)	Room Temperature																																							
Transmission Fluid – fully submerged and pressurized @ 7 psi. (Dextron)	Dip (1)	Room Temperature																																							
<b>Temperature Life</b>	3.2.3.1	Connectors shall be subjected to a temperature of 125 ± 3°C for a period of 1000 hours. At the end of the temperature soak period and after removal from the chamber, the connectors shall meet the insulation resistance and dielectric withstanding voltage requirements specified herein. Connectors shall be operated at rated current throughout the duration of the temperature life test. Upon removal from the chamber at the conclusion of the test, the connectors shall show no visual signs of damage which may be detrimental to the performance of the connector.																																							
<b>Thermal Cycling</b>	3.2.3.2	Connectors shall be subjected to 100 thermal cycles from -40° to +125°C. One cycle shall consist of the transitions from room temperature to -40° to +125°C, and from 125°C to room temperature. One cycle shall be accomplished in a three hour period with a minimum stabilization period of 15 minutes at each temperature extreme. The chamber temperature transition rate shall be a minimum of 1.30°C per minute and a maximum of 6.00°C per minute.																																							

## Receptacle, In-Line\* (Type R)

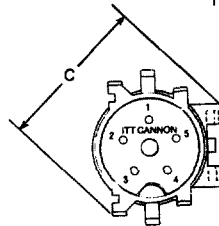
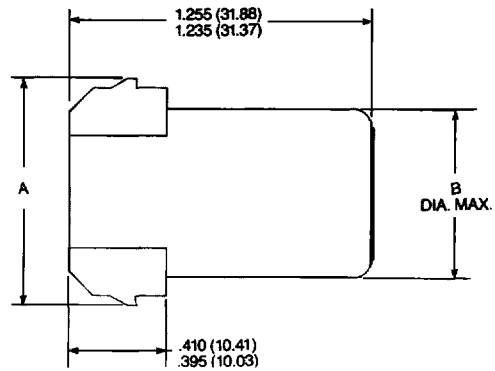
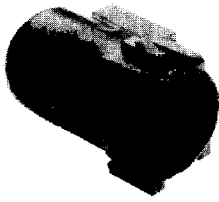

Front-Face View  
5 Cavity Housing

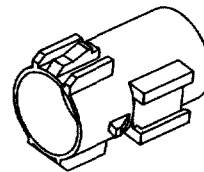

Side View  
Receptacle Assembly

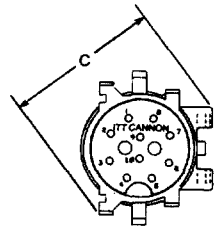

Front-Face View  
10 Cavity Housing

Size	Rating	Part Number	Description	A	B Dia.	C Ref.
5 Cav.	5 Amp	098530-0000	SLC-5R5-00	.950 (24.13)	.710 (18.03)	.960 (24.38)
	13 Amp	098530-0001	SLC-5R13-00	.935 (23.75)		
10 Cav.	5 Amp	098530-0002	SLC-10R5-00	1.230 (31.24)	.990 (25.15)	1.245 (31.62)
	13 Amp	098530-0003	SLC-10R13-00	1.215 (30.86)		

\*Contacts/Lead Assemblies are customer terminated and installed. See 110238-0446, 110238-2004.

## Plug, In-Line\* (Type P)

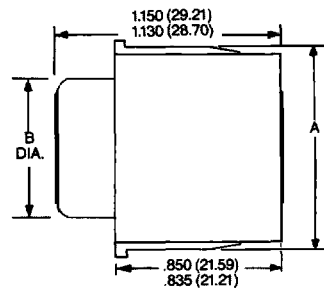
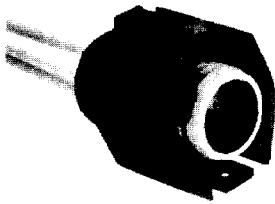

Front-Face View  
5 Cavity Housing

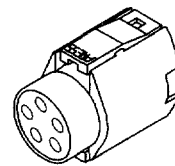

Side View  
Plug Assembly



Front-Face View  
10 Cavity Housing

Size	Rating	Part Number	Description	A	B Dia. Max.
5 Cav.	5 Amp	098532-0000	SLC-5P5-00	1.095 (27.81)	.710 (18.03)
	13 Amp	098532-0001	SLC-5P13-00	1.055 (26.80)	
10 Cav.	5 Amp	098532-0002	SLC-10P5-00	1.375 (34.92)	.990 (25.15)
	13 Amp	098532-0003	SLC-10P13-00	1.340 (34.04)	

\*Contacts/Lead Assemblies are customer terminated and installed. See 110238-0488, 110238-2003.

## Receptacle, PC Board (Type B)

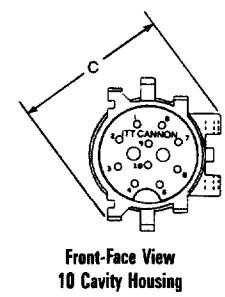
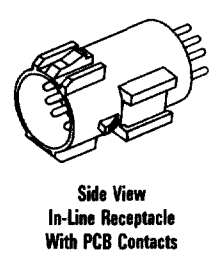
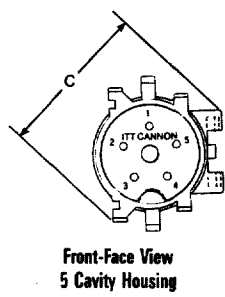
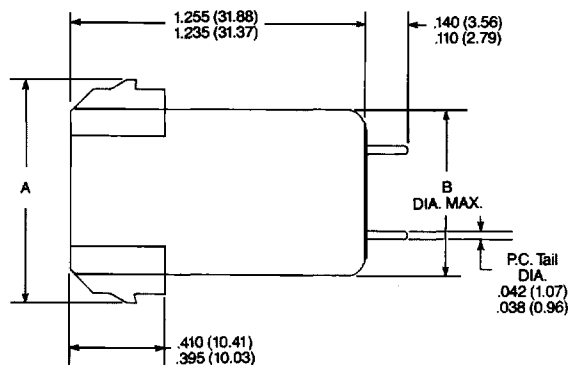

**Receptacle, PCB\* (Includes Contacts Installed – Mates With SLC "P" Types)**

Size	Rating	Part Number	Description	A	B Dia.	C Ref.
5 Cav.	5 Amp	098531-0000	SLC-5B5-00	.950 (24.13)	.710 (18.03)	.960 (24.38)
	13 Amp	098531-0001	SLC-5B13-00	.935 (23.75)		
10 Cav.	5 Amp	098531-0002	SLC-10B5-00	1.230 (31.24)	.990 (25.15)	1.245 (31.62)
	13 Amp	098531-0003	SLC-10B13-00	1.215 (30.86)		

\*PCB Contacts are factory installed.

## Recommended PC Board Pattern

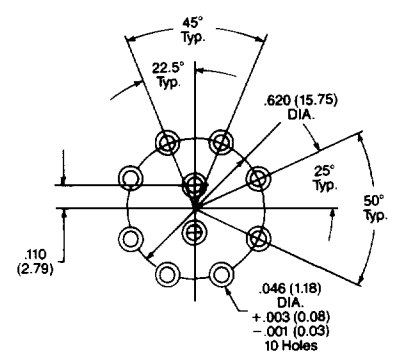
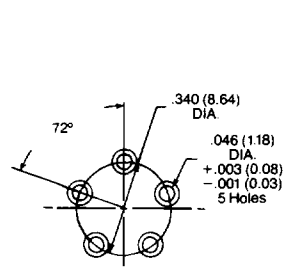

## Snap-Thru Receptacle (Type T)\*

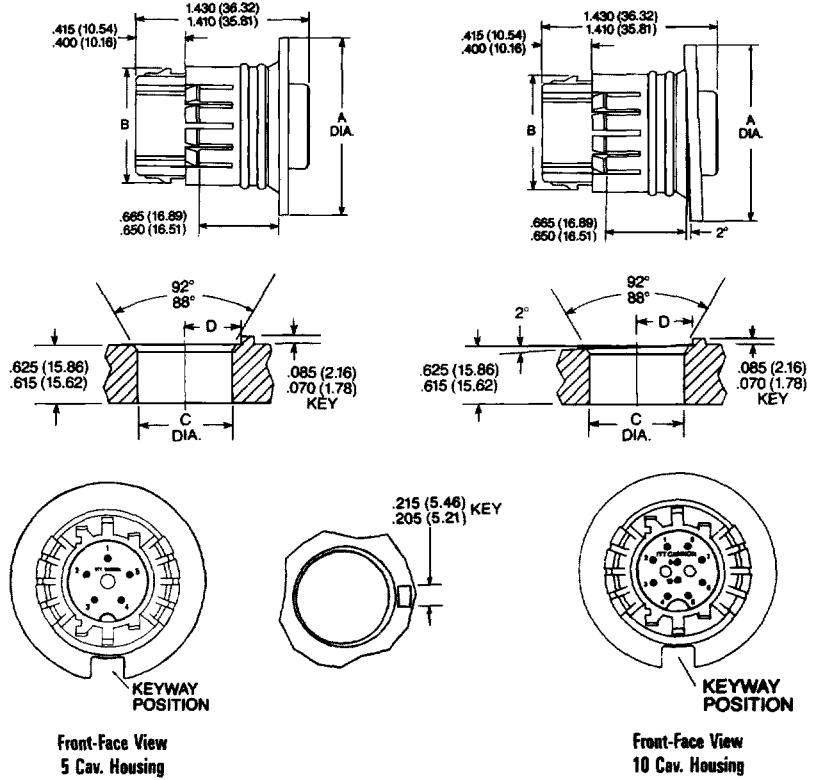
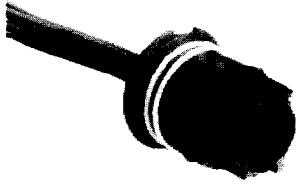

Snap-Thru Receptacle\* (Mates with SLC-"P" Types)

Size	Rating	Part Number	Description	A Dia.	B	C Dia.	D
5 Cav.	5 Amp	098533-0000	SLC-5T5-00	1.465 (37.21)	.950 (24.13)	1.008 (25.60)	.575 (14.60)
	13 Amp	098533-0001	SLC-5T13-00	1.455 (36.96)	.935 (23.75)	1.003 (25.48)	.565 (14.35)
10 Cav.	5 Amp	098533-0002	SLC-10T5-00	1.875 (47.62)	1.230 (31.24)	1.380 (35.05)	.795 (20.19)
	13 Amp	098533-0003	SLC-10T13-00	1.865 (47.37)	1.215 (30.86)	1.375 (34.92)	.785 (19.94)

\*Contacts/Lead Assemblies are customer terminated and installed. (See 110238-0446, 110238-2004)

## Contacts, Stamped

5 and 13 Amp – For Use In 3-5 Contact Body  
 Socket (Use in plugs)

Pin (Use in receptacles)

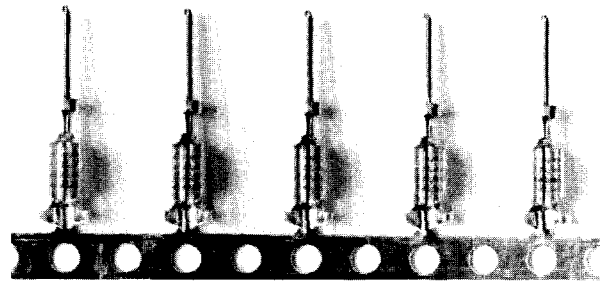
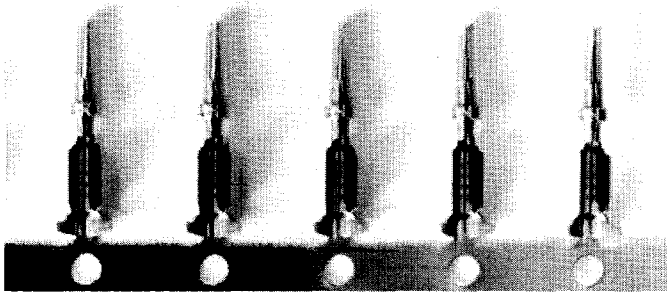

Description	Loose*		Reeled		No. of Contacts
	Pin Part Number	Socket Part Number	Pin Part Number	Socket Part Number	
5 Amps	030-2464-000	030-2480-000	110238-0446	110238-0488	4,500
13 Amps	030-2464-003	030-2480-003	110238-2004	110238-2003	4,000

\*Loose contact part numbers for reference. Contacts sold on reels only.

## Accessories

### Sealing Plugs



Thermoplastic, Color: Natural  
 Part Number: 225-0093-000

### Receptacle Mounting Hardware

Used on "R" Type Connectors – Fits .250 (6.35) hole × .020 (0.51) thick panel.

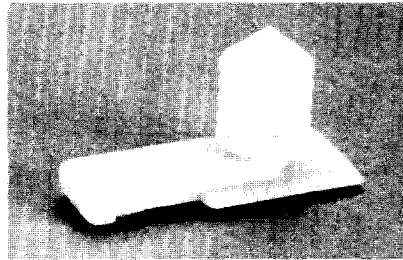

Thermoplastic, Color: Natural  
 Part Number: 980-0008-279

### Wedge Lock

Used on "T" type connectors (customer installed after connector has been inserted through panel).



Thermoplastic, Color: Black  
 Part Number: 317-9765-000 – 5 Cav. housing  
 317-9765-001 – 10 Cav. housing

### Square Flange

Snaps onto "R" and "B" type connectors  
 Thermoplastic, color black.

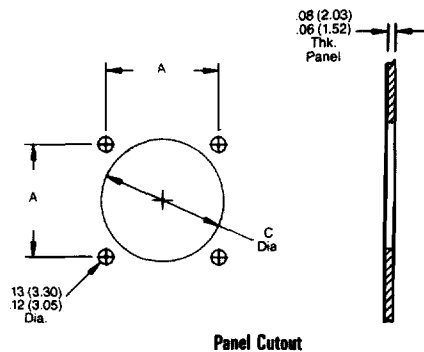
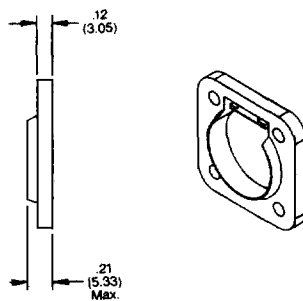
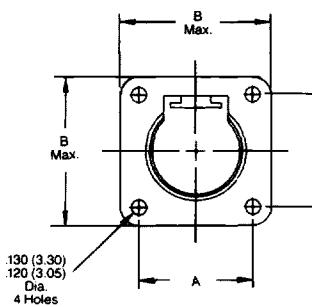

Panel Cutout

Housing Size	Part Number	A BSC	B Max.	C Dia.
5	066-9504-000	.920 (23.37)	1.23 (31.24)	1.00 (25.40) .97 (24.64)
10	066-9504-001	1.120 (28.45)	1.43 (36.32)	1.28 (32.51) 1.25 (31.75)