

April 1997-4

DESCRIPTION

The SM-5102 is a silicon micro-machined, piezoresistive pressure sensing chip. These devices are available in full-scale ranges from 5 to 300 psi and are ideal for OEM and high volume applications.

Provided in die form, these sensors can be mounted on ceramic or PC board substrates as part of an OEM system. They also may be packaged into proprietary, or application specific sensor lines.

Die are probed, inked and diced, and shipped on tape or in waffle packs.

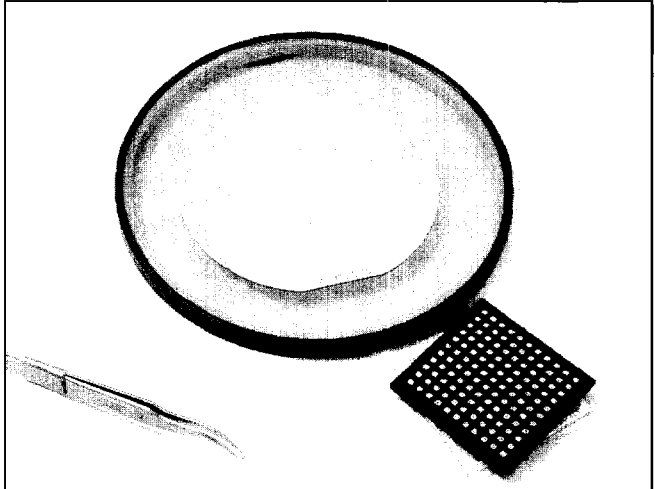

FEATURES

- Low Cost
- Gage and Absolute Versions
- Constant Current or Constant Voltage Drive
- Millivolt Output
- 5, 15, 30, 60, 100 and 300 psi Ranges Available

APPLICATIONS

- Altimeters
- Tire Gauges
- Medical Instrumentation
- Industrial Sensors
- Diving Modules
- Home Appliances

EXAR5007*

CHARACTERISTICS

All parameters are measured at 5V excitation at room temperature unless otherwise specified.

Parameter	Min	Typ	Max	Units
Excitation Voltage	0	5	10	V
Excitation Current	0	1.5	3	mA
Span (FS Range) ¹				
5 psi	75	100	125	mV
15 psi	115	145	175	mV
30 psi	130	165	195	mV
60 psi	130	180	220	mV
100 psi	130	200	250	mV
300 psi	130	220	275	mV
Offset	-50	0	50	mV
TC Span ²		-22 ± 5		%FS/100°C
TC Offset ²		± 7		%FS/100°C
TC Resistance		28 ± 5		%/100°C
Linearity ³	-0.3	± 0.05	0.3	%FS
Bridge Impedance	2.7	3.3	4	kΩ
Proof Pressure	3X			Rated FS
Burst Pressure	5X			Rated FS
Operating Temperature	-40		85	°C
Storage Temperature	-55		125	°C

Notes

¹ Measured at 5V constant voltage excitation.

² Measured from 0 to 70°C.

³ Best fit straight line.

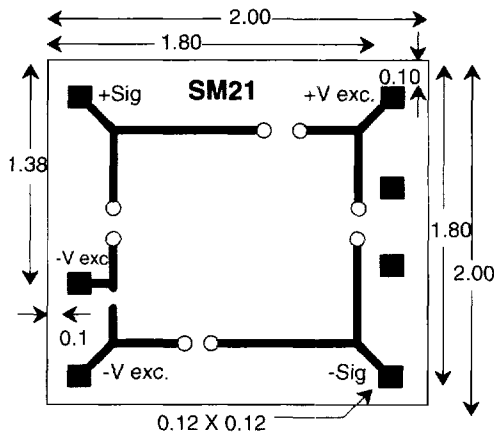

Figure 1. Layout

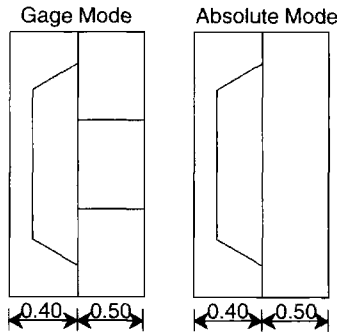

Figure 2. Side View

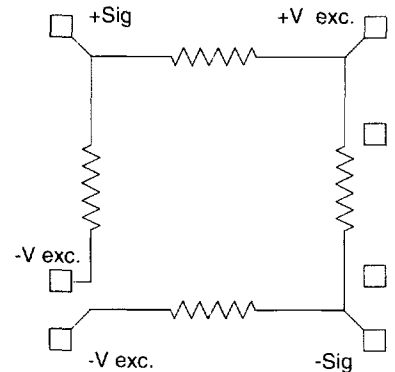

Figure 3. Schematic

Note
All dimensions in millimeters.

ORDERING INFORMATION

Pressure Type

- A: Absolute
- G: Gage

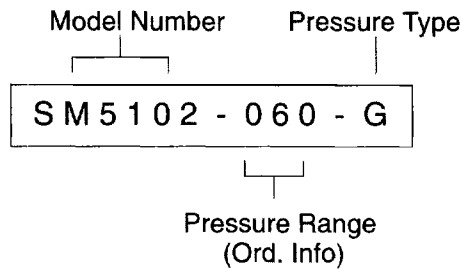

Pressure Range

Ord. Info	psi	BAR	kPa	mmHg	in H ₂ O	mmH ₂ O
005	5	0.345	34.47	258.6	138.4	3515.4
015	15	1.034	103.42	775.7	415.2	10546.1
030	30	2.068	206.84	1551.5	830.4	21092.2
060	60	4.137	413.68	3102.9	1660.8	42184.3
100	100	6.895	689.47	5171.5	2768	70307.2
300	300	20.684	2068.41	15514.5	8304	210921.6

Special Configurations are available. Contact EXAR Corporation for more information.

NOTICE

EXAR Corporation reserves the right to make changes to the products contained in this publication in order to improve design, performance or reliability. EXAR Corporation assumes no responsibility for the use of any circuits described herein, conveys no license under any patent or other right, and makes no representation that the circuits are free of patent infringement. Charts and schedules contained herein are only for illustration purposes and may vary depending upon a user's specific application. While the information in this publication has been carefully checked; no responsibility, however, is assumed for inaccuracies.

EXAR Corporation does not recommend the use of any of its products in life support applications where the failure or malfunction of the product can reasonably be expected to cause failure of the life support system or to significantly affect its safety or effectiveness. Products are not authorized for use in such applications unless EXAR Corporation receives, in writing, assurances to its satisfaction that: (a) the risk of injury or damage has been minimized; (b) the user assumes all such risks; (c) potential liability of EXAR Corporation is adequately protected under the circumstances.

Copyright 1993 EXAR Corporation Silicon Microstructures Division
Datasheet April 1997

Reproduction, in part or whole, without the prior written consent of EXAR Corporation is prohibited.