



Capella Microsystems Inc.

3777 Stevens Creek Blvd., Suite 320

Santa Clara, CA 95051-7364 U.S.A

Tel: (408) 260-3400

FAX: (408) 248-3416

CMI8804 BTL Driver

For CD/CD-ROM

PRELIMINARY DATA SHEET

Revision 0.1

DataSheet4U.com

07/16/99

This preliminary data sheet indicates that this product is still in the design cycle. All specifications are based on design goals only. Capella Microsystems Inc. assumes no responsibility for the use of this product.

Capella Microsystems Inc. reserves the right to make changes in specifications or discontinue this product at any time without notice. Please contact Capella Microsystems Inc. for possible updates before starting a design.

Capella Microsystems Inc. products are not designed for use in life support applications. Any parties who use these products in such applications do so at their own risk and agree to fully indemnify Capella Microsystems Inc. for any damages resulting from such improper usage or sale.



CMI8804 BTL Driver

3777 Stevens Creek Blvd., Suite 320

Santa Clara, CA 95051-7364 U.S.A

Tel: (408) 260-3400

FAX: (408) 248-3416

GENERAL DESCRIPTION

The CMI8804 is a silicon monolithic integrated circuit and is a four channel driver for optical disc motor drivers. The CMI8804 has a wide dynamic range of 4.0V(typ.) at $PreV_{cc}=12V$, $PV_{cc}=5V$, and $RL=8\Omega$. By separating the into pre+power of sled driver, power of a loading driver, and power of an actuator, the CMI8804 has made the power efficiency better by using low supply voltage.

The CMI8804 has integrated and built in to itself a level shift circuit, a thermal-shut-down circuit, and a stand-by mode. The actuator drive is a current feedback type and the current phase lag influenced load inductance is little. On the sled motor driver, input pins consist of (+) and (-), which thus provides various input types, such as the differential input. The loading driver is a single input linear BTL driver.

FEATURES

- ◆ Focus Actuator which controls the height of the pickup to maintain the proper focus.
- ◆ Tracking Actuator which moves the pickup along the closet track.
- ◆ Sled Motor Control which moves the pickup to a track other than the immediate track.
- ◆ Tray Motor Control which opens and closes the tray when inserting or removing the disc.

APPLICATIONS

- ◆ CD-ROM DRIVES
- ◆ CD DRIVES

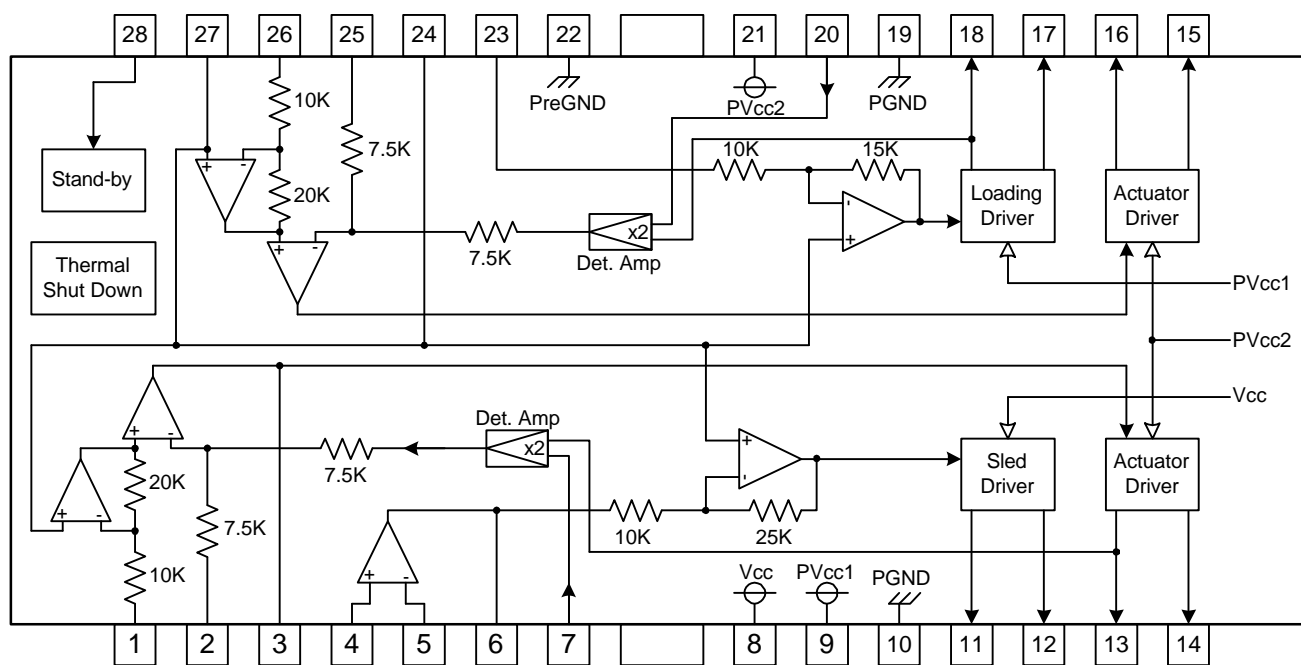

Figure 1: CMI8804 Block Diagram



CMI8804 BTL Driver

3777 Stevens Creek Blvd., Suite 320

Santa Clara, CA 95051-7364 U.S.A

Tel: (408) 260-3400

FAX: (408) 248-3416

Pin Description

Pin #	Pin Name	Description	Pin #	Pin Name	Description
1	VINFC	Input for focus driver	28	STBY	Input for stand-by control
2	CFCerr1	Connection with capacitor for error amplifier	27	BIAS	Input for reference voltage
3	CFCerr2		26	VINTK	Input for tracking driver
4	VINSL+	Non inverting input for OP-amp	25	CTKerr1	for error amplifier
5	VINSL-	Inverting input for OP- amp	24	CTKerr2	Connection with capacitor
6	VOSL	Output of OP- amp	23	VINLD	Input for loading driver
7	VNFFC	Feedback for focus driver	22	PreGND	GND for pre-drive block
8	Vcc	Vcc for pre-drive block and power block of sled	21	PVcc2	Vcc for power block of actuator
9	PVcc1	Vcc for power block of loading	20	VNFTK	Feedback for tracking driver
10	PGND	GND for power block	19	PGND	GND for power block
11	VOSL-	Inverted output of sled	18	VOLD-	Inverted output of loading
12	VOSL+	Non inverted output of sled	17	VOLD+	Non inverted output of loading
13	VOFC-	Inverted output of focus	16	VOTK-	Inverted output of tracking
14	VOFC+	Non inverted output of focus	15	VOTK+	Non inverted output of tracking

Note: Symbol of + and – (output of drivers) means polarity to input pin.

(For example, if the voltage of pin 1 is high, pin 14 is high.)

DataSheet4U.com

Absolute Maximum Ratings

Characteristic	Symbol	Rating	Unit
Supply Voltage	Vcc, PVcc1/2	13.5	V
Power Dissipation	Pd	1.7*	W
Operating Temperature	Topr	-35 ~ 85	°C
Storage Temperature	Tstg	-55 ~ 155	°C

* On less than 3% (percentage occupied by copper foil), 70x70mm³, t=1.6mm, glass epoxy mounting. Reduce power by 13.6mW for each degree above 25°C.

Recommended Operating Conditions

Characteristic	Symbol	Rating	Unit
Supply Voltage	Vcc	4.3 ~ 13.2	V
	PVcc1	4.3 ~ Vcc	
	PVcc2	4.3 ~ Vcc	



CMI8804 BTL Driver

3777 Stevens Creek Blvd., Suite 320

Santa Clara, CA 95051-7364 U.S.A

Tel: (408) 260-3400

FAX: (408) 248-3416

Electrical Characteristics

($T_a=25^\circ\text{C}$, $V_{cc}=12\text{V}$, $PV_{cc1}=PV_{cc2}=5\text{V}$, $\text{BIAS}=2.5\text{V}$, $R_L=8\Omega$, $R_d=0.5\Omega$, $C=100\text{pF}$)

Description	Signal	Condition	min	typ	max	Unit
Quiescent Current	I		-	1.8	2.7	mA
Stand-by Quiescent Current	I		-	-	0.5	mA
Voltage for Stand-by ON	V_{STON}		-	-	0.5	V
Voltage for Stand-by OFF	V_{STOFF}		2.0	-	-	V
Actuator Driver						
Output Offset Current	I_{CO}		-6	-	6	mA
Maximum Output Voltage	V_{OU}		3.6	4.0	-	V
Trans Conductance	gm	$V_{IN} = \text{BIAS} \pm 0.2\text{V}$	1.3	1.5	1.7	A/V
Sled Motor Driver/Pre OP-Amp						
Common Mode Input Range	V_{ICN}		-0.3	-	11.0	V
Input Bias Current	I_{SOP}		-	30	300	nA
Low Level Output Voltage	V_{OLOP}		-	0.1	0.3	V
Output Source Current	I_{SO}		0.3	0.5	-	mA
Output Sink Current	I_{ST}		1	-	-	mA
Sled Motor Driver						
Output Offset Voltage	V_{OOPSL}		-100	0	100	mV
Maximum Output Voltage	V_{OMSL}		7.5	9.0	-	V
Closed Loop Voltage Gain	G_{VSL}	$V_{IN} = \pm 0.2\text{V}$	18.0	20.0	22.0	dB
Loading Motor Driver						
Output Offset Voltage	V_{OOPLO}		-50	0	50	mV
Maximum Output Voltage	V_{OULD}		3.6	4.0	-	V
Closed Loop Voltage Gain	G_{VLD}	$V_{IN} = \text{BIAS} \pm 0.2\text{V}$	13.5	15.5	17.5	dB
Gain Error by Polarity	ΔG_{VLD}	$V_{IN} = \text{BIAS} \pm 0.2\text{V}$	0	1	2	dB

Note: For reference to Electrical Characteristics, see figure 4 (page 6), CMI8804 Test Circuit.
This product is not designed for protection against radioactive rays.

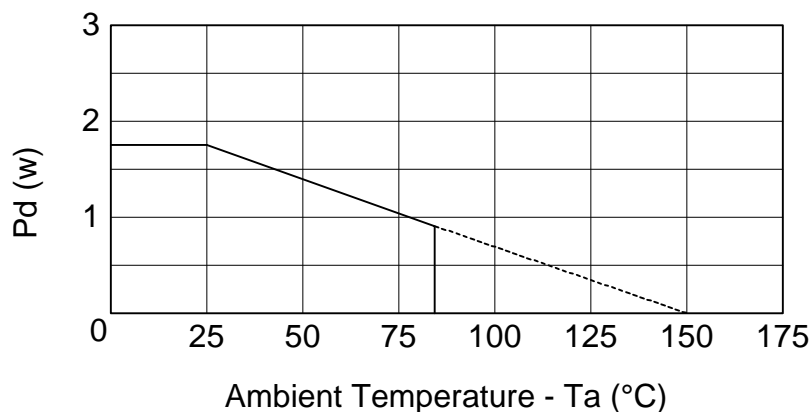

Note: On less than 3% (percentage occupied by copper foil), $70 \times 70 \text{mm}^3$, $t=1.6\text{mm}$, glass epoxy mounting.

Figure 2: CMI8804 Power Dissipation/Electrical Characteristic Curves

www.DataSheet4U.com



CMI8804 BTL Driver

3777 Stevens Creek Blvd., Suite 320

Santa Clara, CA 95051-7364 U.S.A

Tel: (408) 260-3400

FAX: (408) 248-3416

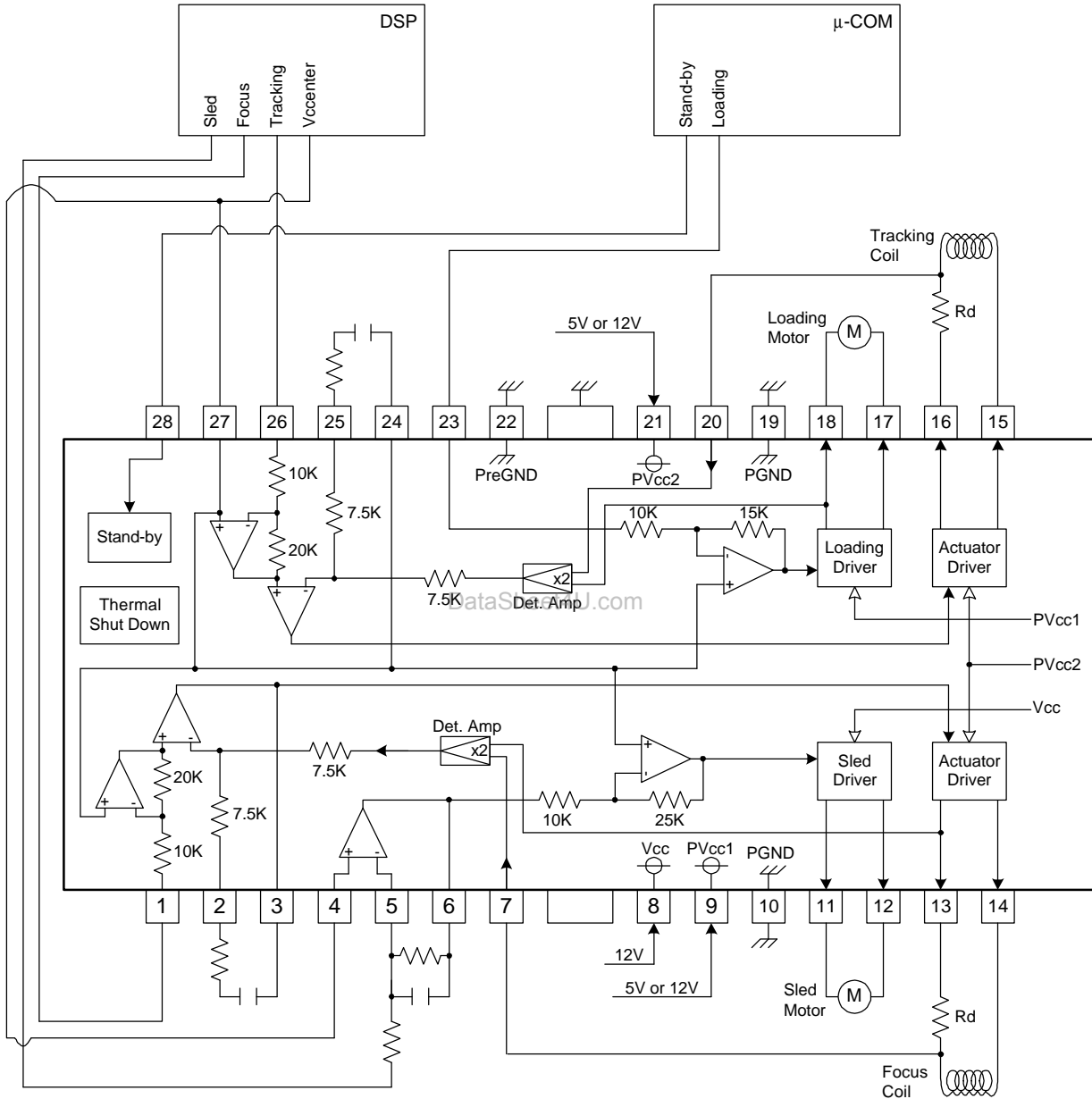

Figure 3: CMI8804 Application Circuit



CMI8804 BTL Driver

3777 Stevens Creek Blvd., Suite 320

Santa Clara, CA 95051-7364 U.S.A

Tel: (408) 260-3400

FAX: (408) 248-3416

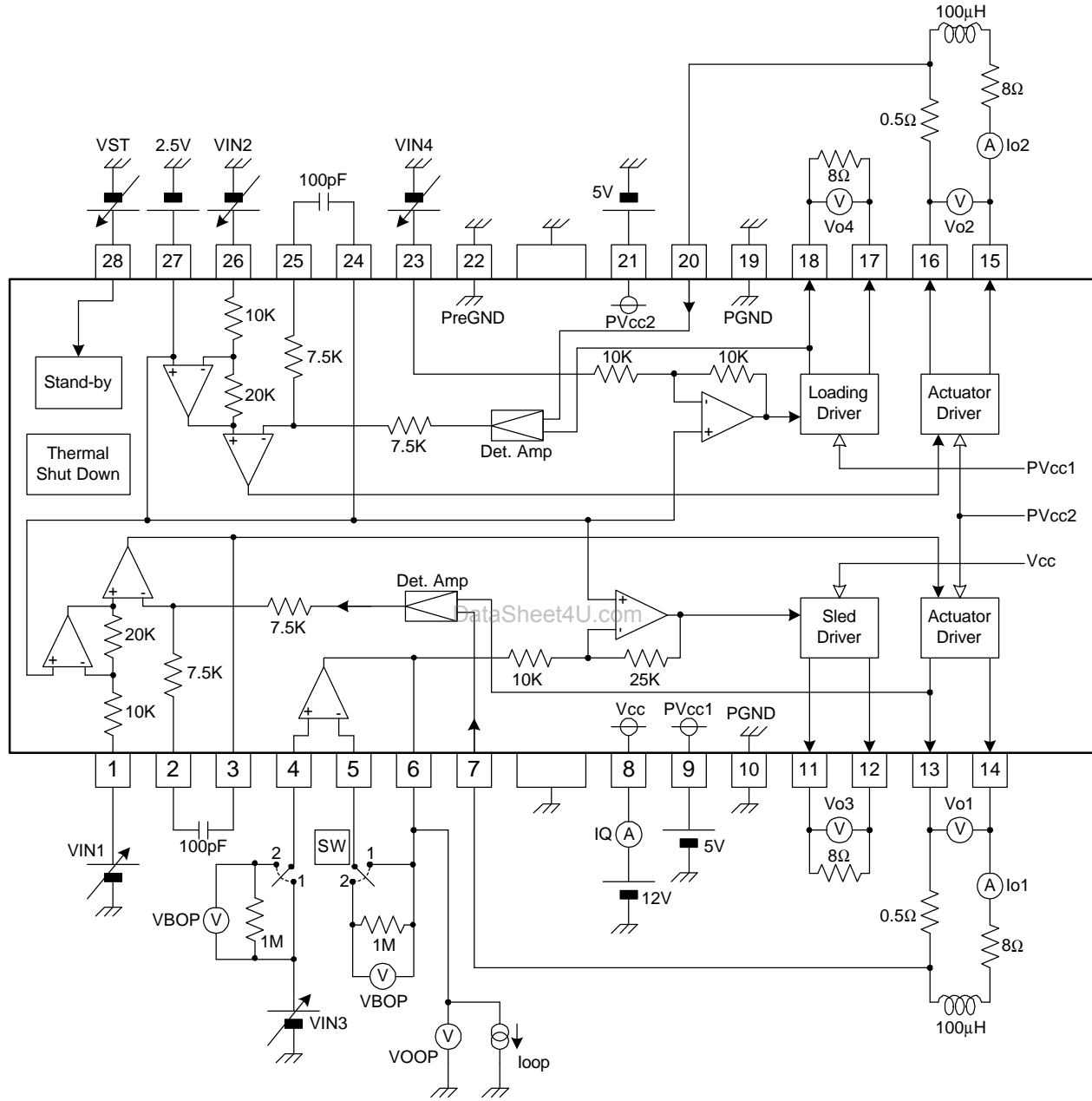

Figure 4: CMI8804 Test Circuit



CMI8804 BTL Driver

3777 Stevens Creek Blvd., Suite 320

Santa Clara, CA 95051-7364 U.S.A

Tel: (408) 260-3400

FAX: (408) 248-3416

Switch Table

Parameter	SW	Input Voltage					Condition	Measure Point
		VIN1	VIN2	VIN3	VIN4	VST		
Quiescent Current	1	2.5V	2.5V	2.5V	2.5V	5.0V		1Ω
Stand-by Quiescent Current	1	2.5V	2.5V	2.5V	2.5V	0.5V		1Ω
Voltage for Stand-by ON	1	2.5V	2.5V	2.5V	2.5V	0.5V		1Ω
Voltage for Stand-by OFF	1	2.5V	2.5V	2.5V	2.5V	2.0V		1Ω
Actuator Driver								
Output Offset Current	1	2.5V	2.5V	2.5V	2.5V	5.0V		Vo1/2
Maximum Output Voltage	1	0V 5V	0V 5V	2.5V	2.5V	5.0V		Vo1/2
Trans Conductance	1	2.3V 2.7V	2.3V 2.7V	2.5V	2.5V	2.5V		Vo1/2
Sled Motor Driver								
Input Bias Current	2	2.5V	2.5V	2.5V	2.5V	5.0V		VBOP/1M
Low Level Output Voltage	1	2.5V	2.5V	0V	2.5V	5.0V		VOOP
Output Source Current	1	2.5V	2.5V	2.5V	2.5V	5.0V	$I_{OOP}=+0.2mA$	VOOP
Output Sink Current	1	2.5V	2.5V	2.5V	2.5V	5.0V	$I_{OOP}=-1mA$	VOOP
Output Offset Voltage	1	2.5V	2.5V	2.5V	2.5V	5.0V		Vo3
Maximum Output Voltage	1	2.5V	2.5V	0V 5V	2.5V	5.0V		Vo3
Closed Loop Voltage Gain	1	2.5V	2.5V	2.3V 2.7V	2.5V	5.0V		Vo3
Loading Driver								
Output Offset Voltage	1	2.5V	2.5V	2.5V	2.5V	5.0V		Vo4
Maximum Output Voltage	1	2.5V	2.5V	2.5V	0V 5V	5.0V		Vo4
Voltage Gain	1	2.5V	2.5V	2.5V	2.3V 2.7V	5.0V		Vo4



CMI8804 BTL Driver

3777 Stevens Creek Blvd., Suite 320

Santa Clara, CA 95051-7364 U.S.A

Tel: (408) 260-3400

FAX: (408) 248-3416

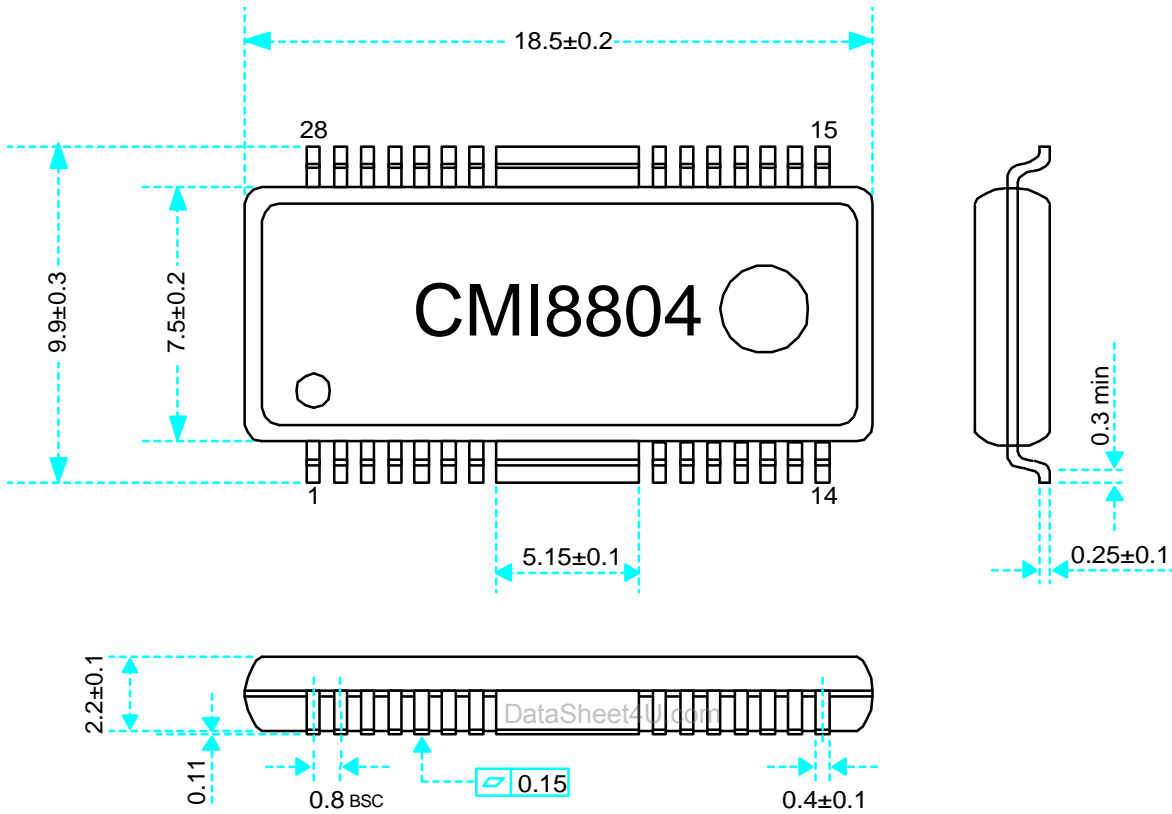

Figure 5: CMI8804 Package Dimensions (In Millimeters)



CMI8804 BTL Driver

3777 Stevens Creek Blvd., Suite 320

Santa Clara, CA 95051-7364 U.S.A

Tel: (408) 260-3400

FAX: (408) 248-3416

NOTES ON USE:

1. Thermal-shut-down circuit built-in. In case IC chip temperature rises to 175°C (typ.), thermal-shut-down circuit operates and output current is muted. Next time IC chip temperature falls below 150°C (typ.), the driver blocks start.
2. In case stand-by-pin voltage under 0.5V or opened, quiescent current is muted. Stand-by-pin voltage should be over 2.0V for normal application.
3. In case supply voltage falls below 3.5V (typ.), output current is muted. Next time supply voltage rises to 3.7V (typ.), the driver blocks start.
4. Bias-pin (pin 27) should be pulled up more than 1.2V. In case bias-pin voltage is pulled down under 0.9V (typ.), output current is muted.
5. Insert the by-pass capacitor between Vcc-pin and GND-pin of IC as possible as near (approximately 0.1μF).
6. Heat dissipation fins are attached to the GND on the inside of the package. Make sure to connect these to the external GND.

Supplement

DataSheet4U.com

Current feedback driver

Trans conductance (output current/input voltage) is shown as follows:

$$g_m = \frac{1}{R_d + R_{WIRE}} \quad (A/V)$$

$R_{WIRE} \neq 0.15\Omega (\pm 0.05\Omega)$:Au wire