

# 8952

## SERVO LOOP COMPENSATOR

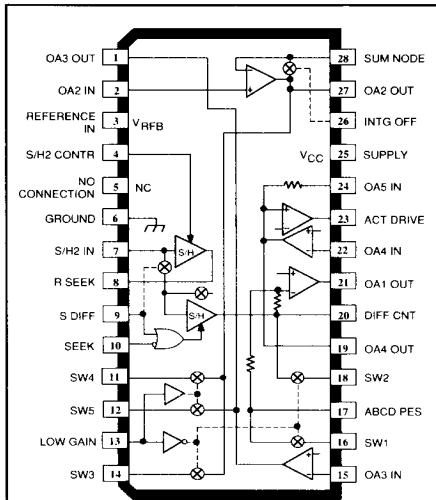

Dwg. No. PC-005

### ABSOLUTE MAXIMUM RATINGS at $T_A = 25^\circ\text{C}$

Supply Voltage, $V_{CC}$ .....	6.0 V
Output Current, $I_{OUT}$ .....	$\pm 1.0$ mA
Op Amp Output Current, $I_{OUT}$ .....	$\pm 5.0$ mA
Input Voltage Range, $V_{IN}$ .....	-0.3 V to $V_{CC} + 0.3$ V
Package Power Dissipation, $P_D$ .....	1.2 W
Operating Temperature Range, $T_A$ .....	0°C to +70°C
Junction Temperature, $T_J$ .....	150°C
Storage Temperature Range, $T_S$ .....	-55°C to +150°C

*Caution: This CMOS device has input static protection but is susceptible to damage when exposed to extremely high static electrical charges.*

The A8952CLW provides all of the active circuitry for the servo loop compensation in the control and drive to the voice coil driver used for head positioning in disk-drive applications. Included are multiple transmission gates, operational amplifiers, and two sample-and-hold amplifiers. Circuit functions are isolated and major circuit nodes are accessible for a complete user-configurable system architecture.

Each circuit function is optimized for the loop compensation application. The signal-path switching transmission gates feature short propagation delays, the operational amplifiers feature low input offset voltages and individual logic-switched feedback loops, and the CMOS sample-and-hold amplifiers provide low droop.

The A8952CLW is supplied in a 28-lead SOIC for surface-mount applications. It is rated for continuous operation over the temperature range of 0°C to +70°C.

### FEATURES

- User-Configurable Architecture  
Loop Compensation
- Low Offset Operational Amplifiers
- Low Droop Sample & Hold Amplifiers
- Short Delay Transmission Gates

Always order by complete part number: **A8952CLW**.

# 8952 LOOP COMPENSATOR

## FUNCTIONAL BLOCK DIAGRAM

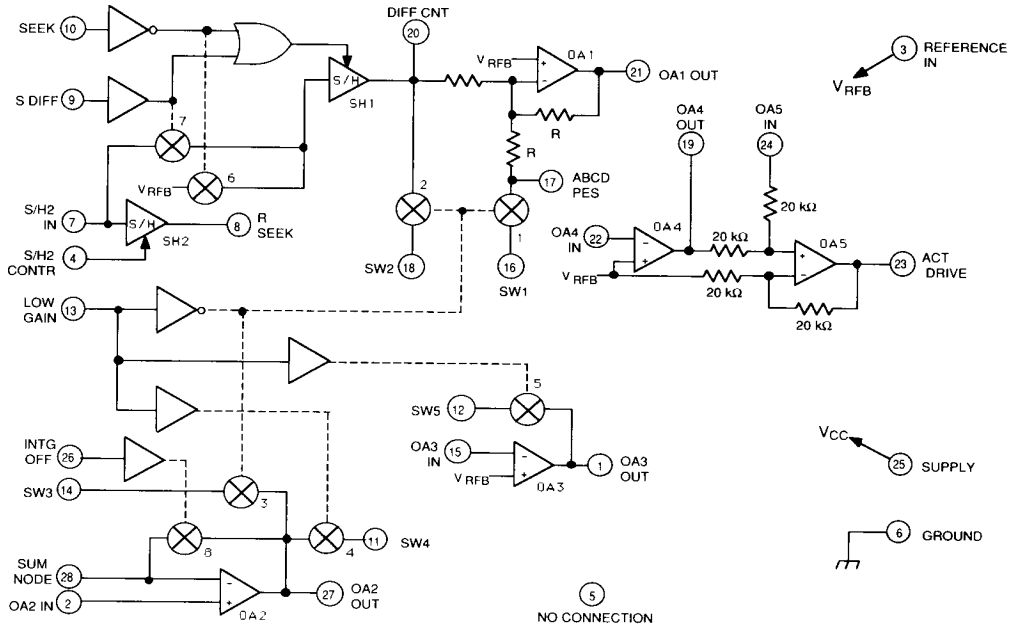

Dwg. No. FC-002

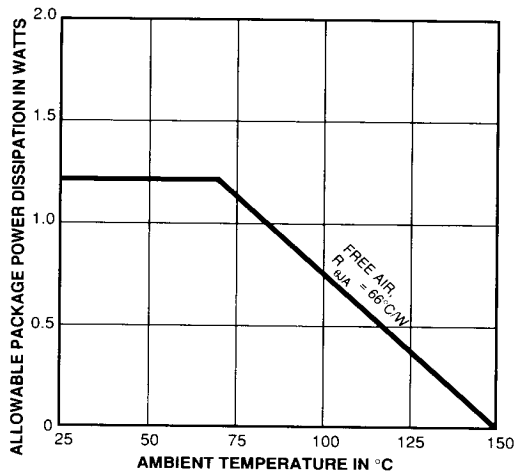

Dwg. No. GP-034-1

# 8952

## LOOP COMPENSATOR

### ELECTRICAL CHARACTERISTICS at $T_A = +25^\circ\text{C}$ , $V_{CC} = 5.0\text{ V}$

Characteristic	Symbol	Test Conditions	Limits			Units
			Min.	Typ.	Max.	
Supply Voltage Range	$V_{CC}$	Operating	4.5	5.0	5.5	V
Supply Current	$I_{CC}$	No Load	–	4.5	9.0	mA

### TRANSMISSION GATE PARAMETERS

On Resistance	$R_{ON}$		–	140	280	$\Omega$
Propagation Delay	$t_{PD}$		–	–	50	ns
Input Current	$I_{IO}$	$V_{IN} = 0\text{ V}$	–	<1.0	100	nA
		$V_{IN} = 5.0\text{ V}$	–	<1.0	100	nA
INTG OFF Bias Current	$I_{IB}$	$V_{IN} = 0\text{ V}$	–	<1.0	100	nA
		$V_{IN} = 5.0\text{ V}$	–	<1.0	100	nA
ABCD PES Bias Current	$I_{IB}$	$V_{IN} = 2.5\text{ V}$	–	1.0	2.0	$\mu\text{A}$
LOW GAIN Bias Current	$I_{IB}$	$V_{IN} = 5.0\text{ V}$	–	3.0	300	nA
S DIFF Bias Current	$I_{IB}$	$V_{IN} = 0\text{ V}$	–	<1.0	100	nA
		$V_{IN} = 5.0\text{ V}$	–	<1.0	100	nA
Switch Bias Current (SW1, SW2, and SW3)	$I_{IB}$	$V_{IN} = 0\text{ V}$	–	<1.0	50	nA
		$V_{IN} = 5.0\text{ V}$	–	<1.0	50	nA
Attenuation	$\alpha$	$f = 1\text{ kHz}$ , $V_{in} = 800\text{ mV}_{RMS}$	–	80	–	dB
Distortion	THD	$f = 1\text{ kHz}$ , $V_{in} = 800\text{ mV}_{RMS}$	–	<0.1	–	%

### OPERATIONAL AMPLIFIER PARAMETERS

Input Offset Voltage	$V_{IO}$	$V_{IN} = 2.5\text{ V}$ , $I_{OUT} = 0\text{ mA}$	–	0.75	4.0	mV
Input Bias Current	$I_{IB}$	$V_{IN} = 2.5\text{ V}$ , $I_{OUT} = 0\text{ mA}$	–	35	250	nA
Input Offset Current	$I_{OS}$		–	4.0	50	nA
Open Loop Gain	$A_e$	$I_{OUT} = 0\text{ mA}$	60	100	–	dB
Gain Bandwidth Product	BW	No Load	–	1.0	–	MHz
Slew Rate	SR		–	1.0	–	V/ $\mu\text{s}$
Output Saturation Voltage	$V_{CE(SAT)}$	$I_{OUT} = -900\text{ }\mu\text{A}$	–	0.9	1.0	V
		$I_{OUT} = 900\text{ }\mu\text{A}$	–	0.9	1.0	V
Reference Input Bias Current	$I_{RFB}$	Total input current, $V_{RFB} = 2.5\text{ V}$	–	300	750	nA
Power Supply Rejection Ratio	PSRR	$\Delta V_{CC} = 1.0\text{ V}$	60	75	–	dB

Continued...

# 8952

## LOOP COMPENSATOR

...Electrical Characteristics (continued)

Characteristic	Symbol	Test Conditions	Limits			
			Min.	Typ.	Max.	Units

### SAMPLE AND HOLD PARAMETERS

Gain	$A_e$	$\Delta V_{in} = 1.0 \text{ V}$	-	1.0	-	V/V
Output Offset Voltage	$V_{OO}$		-	4.0	12.5	mV
Pedestal Error	$E_p$	$V_{IN} = 2.5 \text{ V}$	-	$\pm 10$	$\pm 50$	mV
Droop	$\Delta V_O/t$	$V_{IN} = 2.5 \text{ V}, t = 10 \text{ ms}$	-	100	500	$\mu\text{V}/\text{ms}$
SEEK Bias Current	$I_{IB}$	$V_{IN} = 0 \text{ V}$	-	<1.0	100	nA
		$V_{IN} = 5.0 \text{ V}$	-	<1.0	100	nA
S/H2 IN Bias Current	$I_{IB}$	$V_{IN} = 2.5 \text{ V}$	-	30	350	nA
S DIFF Bias Current	$I_{IB}$	$V_{IN} = 0 \text{ V}$	-	<1.0	100	nA
		$V_{IN} = 5.0 \text{ V}$	-	<1.0	100	nA

Negative current is defined as coming out of (sourcing) the specified device terminal.

Typical Data is for design information only.

# 8952 LOOP COMPENSATOR

## TYPICAL DISK-DRIVE APPLICATION USING A8951CLW AND A8952CLW

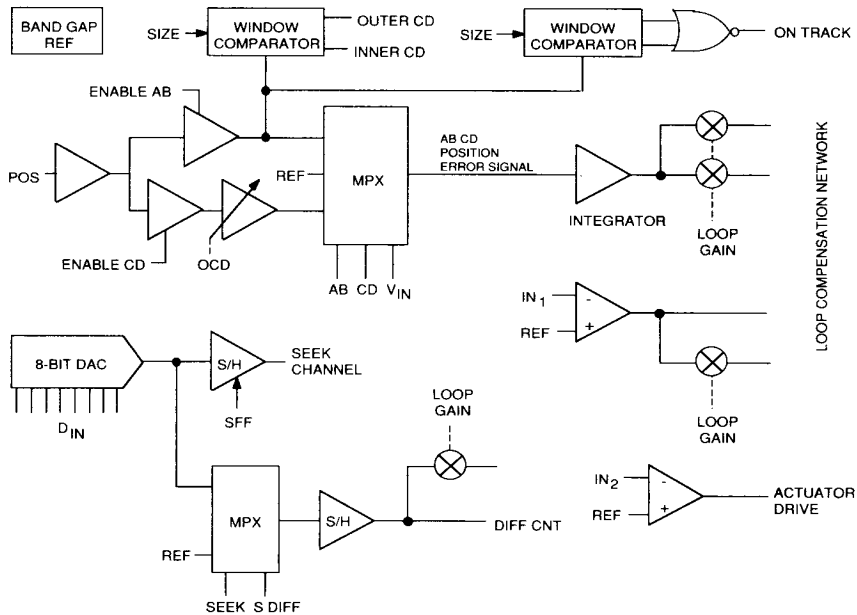

Dwg. No. FC-004

Voice-coil servo motors in disk-drive head-positioning systems utilize complex algorithms and sophisticated circuitry to provide good track-seeking and track-following performance. A typical hard-disk track geometry requires precise voice-coil motor control to ensure accurate positioning of the head above the desired track.

The A8951CLW servo controller system and A8952CLW servo loop compensator are companion devices that provide most of the circuitry to accomplish the head-positioning servo functions. A digital velocity command is converted into an analog signal and, through signal processing with multiple operational amplifiers and sample-and-hold circuits, is utilized to develop a position-error signal to correct the servo loop.

Surface-mount technology provides major benefits of reduced package size and weight, and improved system reliability through the reduction of printed wiring board through holes. Improved quality as well as lower assembly cost are obtained through the adaptability of these devices to high-speed, automated, pick-and-place assembly.