



Dual Programmable Clock Generator

Features

- Two independent clock outputs ranging from 320 kHz to 100 MHz
- Individually programmable PLLs use 22-bit serial word
- Low-skew $\div 1$, $\div 2$, and $\div 4$ CLKA outputs
- Phase-locked loop oscillator input derived from external low-frequency reference clock (1 MHz – 25 MHz) or external crystal (2 MHz – 24 MHz)
- Sophisticated internal loop-filter requires no external components or manufacturing tweaks as commonly required with external filters

- Three-state control disables outputs for test purposes (optional)
- 5V operation
- Low-power, high-speed CMOS technology
- Available in 16-pin SOIC package

Functional Description

The ICD2051 Programmable Clock Generator offers two fully user-programmable phase-locked loops in a single package. The outputs may be changed "on the fly" to any desired frequency value between 320 kHz and 100 MHz. The ICD2051 is ideally suited for any design where one or more multiple or varying frequencies are

required, thus replacing more expensive metal can oscillators.

The capability to dynamically change the output frequency adds a whole new degree of freedom for the electrical engineer. Some examples of the uses for this device include: laptop computers, in which slowing the speed of operation can mean less power consumption or speeding it up can mean faster operation; graphics board dot clocks to allow dynamic synchronization with different brands of monitors or display formats; and on-board test strategies where the ability to skew a system's desired frequency (for example $\pm 10\%$) allows worst case evaluations.

Logic Block Diagram

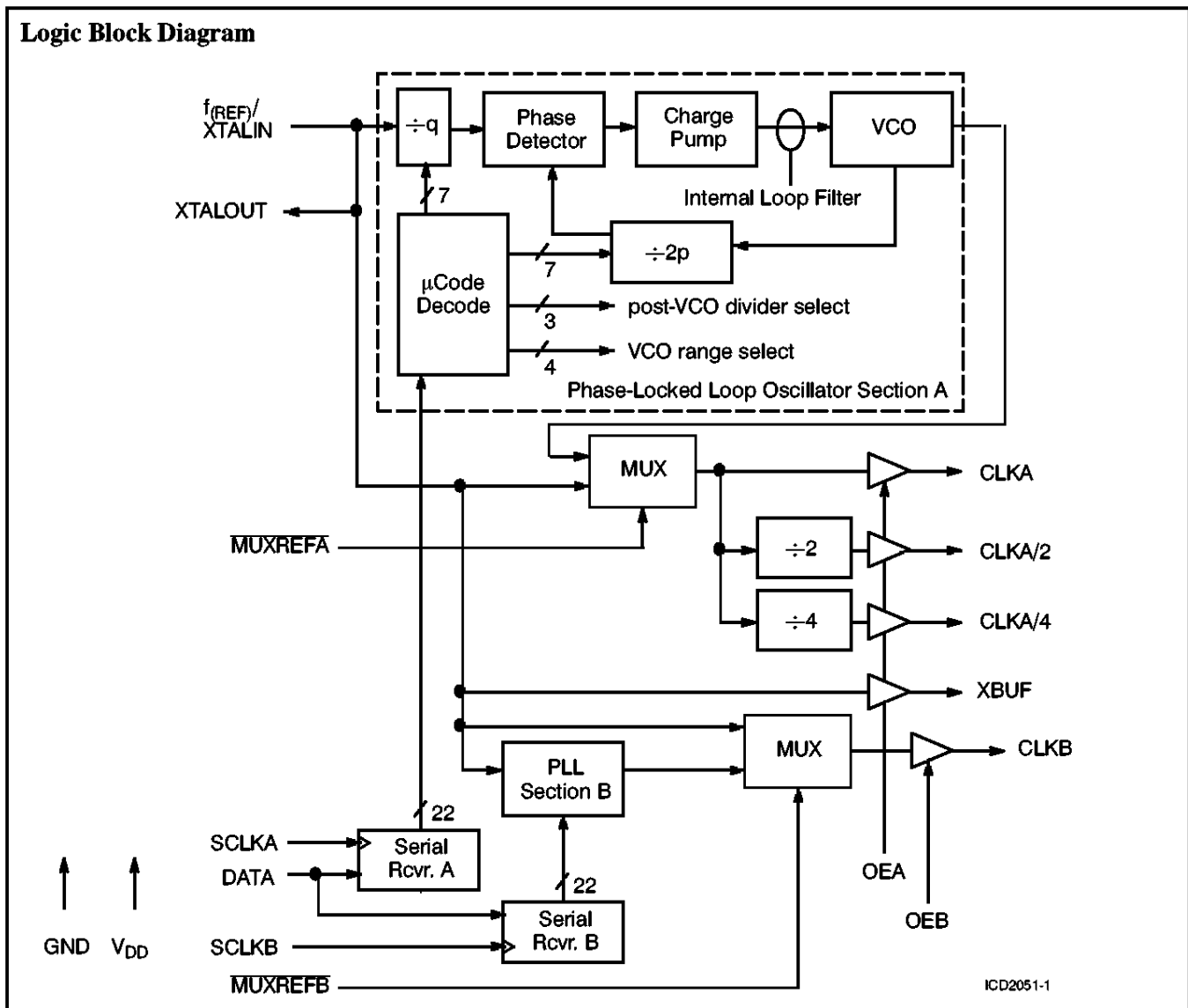

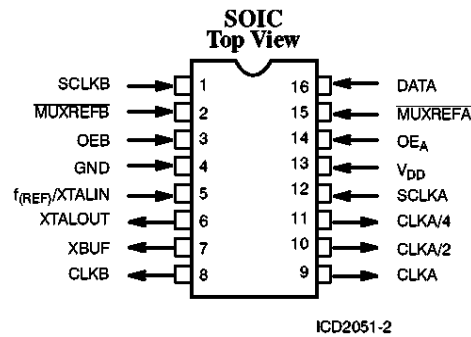
Pin Configuration

Pin Summary

Name	Number	Description
SCLKB	1	Serial clock input line for CLKB
MUXREFB	2	MUXREFB = 0, CLKB equals input reference frequency MUXREFB = 1, CLKB equals programmed frequency This is used if glitch-free frequency changes are required.
OEB	3	Three-states CLKB outputs when pulled LOW. (Internal pull-up allows for no-connect if three-state operation is not needed.)
GND	4	Ground
f _{REF} / XTALIN ^[1]	5	Reference Oscillator input for all internal phase-locked loops
XTALOUT ^[1]	6	Oscillator output to a reference crystal.
XBUF	7	Buffered Crystal Oscillator Output
CLKB	8	CLKB Programmable Output
CLKA	9	CLKA Programmable Output
CLKA/2	10	CLKA divided by 2 (low skew)
CLKA/4	11	CLKA divided by 4
SCLKA	12	Serial clock input line for CLKA.
V _{DD}	13	+5V
OEA	14	Three-states CLKA outputs when pulled LOW. (Internal pull-up allows for no-connect if three-state operation is not needed.)
MUXREFA	15	MUXREFA = 0, CLKA equals input reference frequency MUXREFA = 1, CLKA equals programmed frequency This is used if glitch-free frequency changes are required.
DATA	16	Serial data input line for both programmable PLLs

Note:

- For best accuracy, use a parallel-resonant crystal, assume C_{LOAD} = 17 pF.

General Considerations

Programming the ICD2051

The desired output frequency is defined via a serial interface, with a 22-bin number shifted in. The ICD2051 has two programmable PLLs (CLKA and CLKB), requiring a 22-bit programming word (W) to be loaded into each channel independently. This word contains 5 fields:

Table 1. Programming Word Bit Fields

Field	# of bits	Notes
Index (I)	4	MSB (Most Significant Bits)
P Counter value (P')	7	
Reserved (R)	1	normally set to logic 1
Mux (M)	3	
Q Counter value (Q')	7	LSB (Least Significant Bits)

The frequency of the programmable oscillator $f_{(VCO)}$ is determined by these fields as follows:

$$P' = P - 3$$

$$Q' = Q - 2$$

$$f_{(VCO)} = 2 \times f_{(REF)} \times P/Q$$

where $f_{(REF)}$ = Reference frequency (between 1 MHz – 25 MHz)

The value of $f_{(VCO)}$ must remain between 40 MHz and 120 MHz. Therefore, for output frequencies below 40 MHz, $f_{(VCO)}$ must be multiplied up into the required range. To accomplish this, a post-VCO Divisor is selected by setting the values of the Mux field (M) as follows:

Table 2. Mux Field (M)

M	Divisor
000	1
001	2
010	4
011	8
100	16
101	32
110	64
111	128

The Index field (I) is used to preset the VCO to an appropriate range. The value for this field should be chosen from *Table 3*. (Note that this table is referenced to the VCO frequency $f_{(VCO)}$, rather than to the desired output frequency.)

Table 3. Index Field (I)

I	$f_{(VCO)}$ (MHz)
0000	40.0 – 42.5
0001	42.5 – 47.5
0010	47.5 – 53.5
0011	53.5 – 58.5
0100	58.5 – 62.5
0101	62.5 – 68.5
0110	68.5 – 69.0
0111	69.0 – 82.0
1000	82.0 – 87.0
1001	87.0 – 92.0
1010	92.0 – 92.1
1011	92.1 – 105.0
1100	105.0 – 115.0
1101	115.0 – 120.0
1110	115.0 – 120.0
1111	115.0 – 120.0

If the desired VCO frequency lies on a boundary in the table (if it is exactly the upper limit of one entry and the lower limit of the next) then either index value may be used (since both limits are tested), but we recommend using the higher one.

To assist with these calculations, Cypress/IC Designs provides *BitCalc* (Part #ICD/BCALC), a Windows™ program which automatically generates the appropriate programming words from the user's reference input and desired output frequencies. The software also assembles the program words for control and power-down registers. Contact your local Cypress representative for more information.

Programming Constraints

There are five primary programming constraints the user must be aware of:

Table 4. Programming Constraints

Parameter	Minimum	Maximum
$f_{(REF)}$	1 MHz	25 MHz
$f_{(REF)}/Q$	200 kHz	1 MHz
$f_{(VCO)}$	40 MHz	120 MHz
Q	3	129
P	4	130

The constraints have to do with trade-offs between optimum speed and lowest noise, VCO stability and factors affecting the loop equation. The factors are listed for completeness sake; however, by using the *BitCalc* program all of these constraints become transparent.

ICD2051 Programming Example

The following is an example of the calculations *BitCalc* performs: Derive the proper programming word for a 39.5 MHz output frequency, using 14.31818 MHz as the reference frequency:



Since 39.5 MHz < 40 MHz, double it to 79.0 MHz. Set M to 001. Set I to 0111. The result:

$$f_{(VCO)} = 79.0 = (2 \times 14.31818 \times P/Q)$$

$$P/Q = 2.7857$$

Several choices of P and Q are available:

Table 5. P and Q Value Candidates

P	Q	f(VCO) (MHz)	Error (PPM)
69	25	79.0363	460
80	29	78.9969	40
91	33	78.9669	419

Choose (P, Q)=(80,29) for best accuracy (40 ppm).

Therefore:

$$P' = P - 3 = 80 - 3 = 77 = 1001101 \text{ (4dH)}$$

$$Q' = Q - 2 = 29 - 2 = 27 = 0011011 \text{ (1bH)}$$

The programming word, W is generated by concatenating I=0111, P'=1001101, R=1, M=001, Q'=0011011 to obtain

$$W = 0111100110110010011011 \text{ (1e6c9bH)}$$

A LOW-to-HIGH transition on SCLKA/SCLKB (depending on appropriate channel) is used to shift the programming word W into DATA as a serial bit stream, LSB first. (See the set-up and hold timing specifications later in this datasheet.) If more than 22 shifts are performed, only the last 22 data bits received will be retained.

Glitch-Free Frequency-Modification Procedure

When changing to a new frequency, there is a period of time when the output signal will be in transition and may glitch due to changes in the post divider. For applications where it is critical that the output clock not glitch and always maintain some known value, the MUXREFA and MUXREFB inputs must be used. Under normal operation, MUXREF(X) is HIGH and the output clocks are at the programmed value. When MUXREF(X) is brought LOW, the reference clock is now multiplexed to the associated output clock. The output remains at this fixed frequency while the programmed frequency seeks its new value.

When programming the ICD2051, use the MUXREF inputs in the following manner:

1. Set MUXREF(X) to a LOW state. This will set the output to the reference frequency. The transition is guaranteed to be glitch-free. (See the timing specifications.)
2. Shift in the desired output frequency value via a 22-bit word (as defined above) using the appropriate SCLK and DATA lines.
3. After the last bit is shifted in, the VCO will settle to the new state (within .01% of the actual output frequency) within 10 msec.
4. Set MUXREF(X) to a HIGH state. This will set the output to the new programmed frequency. This transition is guaranteed to be glitch-free. (See Serial Programming Timing in the Switching Waveforms section of this datasheet.)

Skew-Controlled ÷2 on CLKA

The CLKA output is available concurrently as ÷1, ÷2, and ÷4 values of the desired output. The ÷1 and ÷2 outputs are also closely matched in order to minimize the phase differences between the two outputs. Typical phase coherence is less than 2

ns of skew between the two outputs, with 1 ns or less available as an order option.

Output Frequency Accuracy

The accuracy of the ICD2051 output frequencies depends on the target output frequency. As stated previously, the output frequencies of the ICD2051 are integrally related to the input reference frequency:

$$f_{(OUT)} = 2 \times f_{(REF)} \times P/Q$$

Only certain output frequencies are possible for a particular reference frequency. However, the ICD2051 normally produces an output frequency within 0.1% of the desired output frequency. Specifics regarding accuracy (ppm) are given for any desired output frequency as part of the *BitCalc* program output.

Three-State Output Operation

The OEA or OEB signal, when pulled LOW, will three-state the clock output line (CLKA or CLKB respectively). This supports wired-OR connections between external clock lines, and allows for procedures such as automated testing where the clock must be disabled. The OE signals contain internal pull-ups; they can be left unconnected if three-state operation is not required.

Estimating Total Current Drain

Actual current drain is a function of frequency and of circuit loading. The operating current of a given output is given by the equation: $I = C \cdot V \cdot f$, where I=current, C=load capacitance (max. 25 pF), V=output voltage (usually 5V), and f=output frequency (in MHz).

To calculate total operating current, sum the following:

- XBUF ⇒ $C \cdot V \cdot f_{(REF)}$
- CLKA ⇒ $C \cdot V \cdot f_{(CLKA)}$
- CLKA/2 ⇒ $C \cdot V \cdot f_{(CLKA/2)}$
- CLKA/4 ⇒ $C \cdot V \cdot f_{(CLKA/4)}$
- CLKB ⇒ $C \cdot V \cdot f_{(CLKB)}$
- Internal ⇒ 12 mA

This gives an approximation of the actual operating current. For unconnected output pins, one can assume 5–10 pF loading, depending on package type.

Typical values:

Table 6. Typical Load Current Values

Frequency	Load	Current (mA)
low	none	15
high	none	40
high	high	100



Maximum Ratings

(Above which the useful life may be impaired. For user guidelines, not tested.)

Supply Voltage to Ground Potential -0.5V to +7.0V
 DC Input Voltage -0.5V to V_{DD} +0.5V
 Storage Temperature -65°C to +150°C
 Max soldering temperature (10 sec) 260°C
 Junction temperature 125°C

Package power dissipation 525 mWatts

Operating Range

Ambient Temperature	V _{DD} & AV _{DD}
0°C ≤ T _{AMBIENT} ≤ 70°C	5V ± 5%

Operating Conditions

Parameter	Description	Min.	Max.	Unit
V _{DD}	Supply Voltage	4.75	5.25	V
T _A	Ambient Operating Temperature	0	70	°C
C _L	Load Capacitance		25	pF

Electrical Characteristics Over the Operating Range

Parameter	Description	Test Conditions	Min.	Max.	Unit
V _{OH}	Output HIGH Voltage	I _{OH} = -4.0mA	2.4		V
V _{OL}	Output LOW Voltage	I _{OL} = 4.0 mA		0.4	V
V _{IH}	Input HIGH Voltage	Except XTALIN pins	2.0		V
V _{IL}	Input LOW Voltage	Except XTALIN pins		0.8	V
I _{IH}	Input HIGH Current	V _{IN} = 5.25V		150	μA
I _{IL}	Input LOW Current	V _{IN} = 0V		-250	μA
I _{OZ}	Output Leakage Current	Three-state outputs		10	μA
I _{DD}	Power Supply Current	V _{DD} = V _{DD} max., 100 MHz, V _{IN} = V _{DD} or 0V	15	100	mA

Switching Characteristics Over the Operating Range^[2]

Parameter	Name	Description	Min.	Max.	Unit
	Output Frequency		0.320	100	MHz
$f_{(REF)}$	Reference Frequency	Reference Oscillator nominal value	1	25	MHz
$t_{(REF)}$	Reference Clock Period	$t_{(REF)} = 1/f_{(REF)}$	40	1000	ns
	Duty Cycle	Duty cycle for the output oscillators defined as $t_{1A} + t_{1B}$	40%	60%	
t_2	Output Rise Time	Rise time for the outputs into a 25-pF load		3	ns
t_3	Output Fall Time	Fall time for the outputs into a 25-pF load		3	ns
t_4	CLKA/2/4 skew	Skew delay between the CLKA output and the CLKA/2 and CLKA/4 outputs		2	ns
t_5	MUXREF Set-Up Time	Delay required after MUXREF goes LOW prior to starting the SCLK clock line	t_{freq1}		ns
t_6	SCLK Cycle Time	Minimum cycle time for the SCLK clock	$2 \cdot t_{(REF)}$		ns
t_{6H}	SCLK HIGH Time	Minimum HIGH time for the SCLK clock	$t_{(REF)}$		ns
t_{6L}	SCLK LOW Time	Minimum LOW time for the SCLK clock	$t_{(REF)}$		ns
t_7	Output Clock Stable Time	Time required for CLKA or CLKB output to become valid after last SCLK clock		10	msec
t_8	Data Set-Up Time	Time required for the data to be valid prior to the rising edge of SCLK	10		ns
t_9	Data Hold Time	Time required for the data to remain valid after the rising edge of SCLK	5		ns
t_{10}	Transition Time	Time for CLKA or CLKB to go HIGH after assertion of MUXREF	0	t_{freq1}	ns
t_{11}	Transition Time	Delay of CLKA or CLKB prior to valid $t_{(REF)}$ signal at output	$t_{(REF)}/2$	$3(t_{(REF)}/2)$	ns
t_{12}	Transition Time	Time for CLKA or CLKB to go HIGH after release of MUXREF	0	$t_{(REF)}$	ns
t_{13}	Transition Time	Delay of CLKA or CLKB prior to valid new frequency at output	$t_{freq2}/2$	$3(t_{freq2}/2)$	ns
t_{14}	Output Disable Time	Time for the outputs to go into three-state mode after OE signal assertion		12	ns
t_{15}	Output Enable Time	Time for the outputs to recover from three-state mode after OE signal goes HIGH		12	ns

Note:

2. Input capacitance is typically 10 pF, except for the crystal pads.

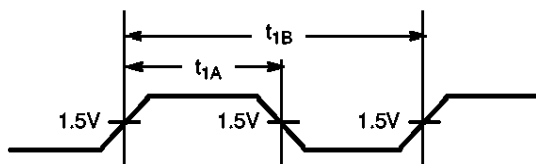
Switching Waveforms
Duty Cycle Timing

ICD2051-3

Switching Waveforms (continued)

Rise and Fall Times

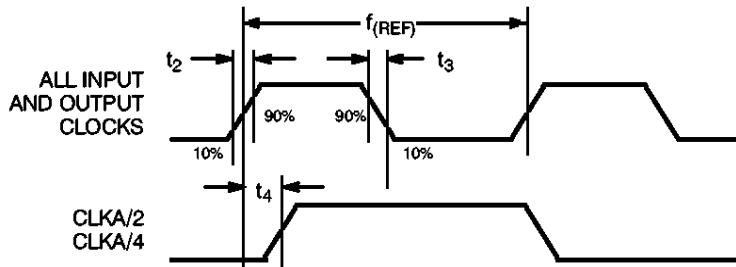

ICD2051-4

Serial Programming Timing

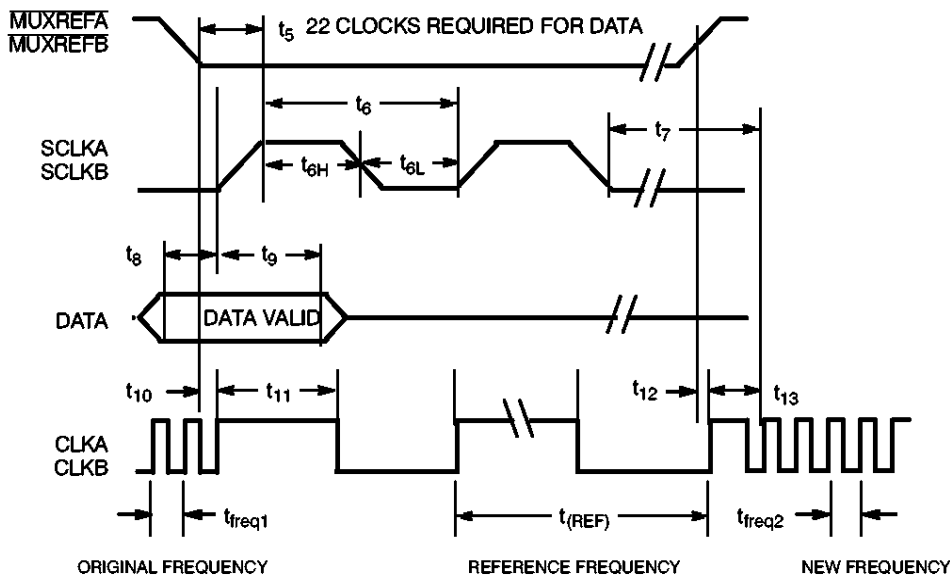

ICD2051-5

Three-State Timing

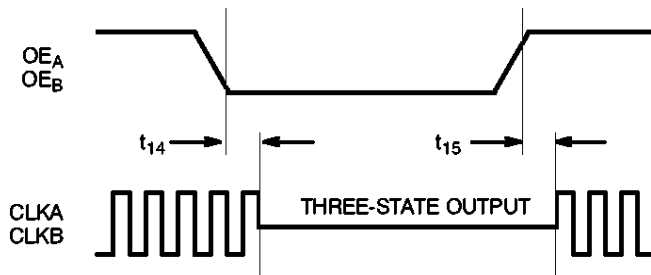

ICD2051-6

Test Circuit

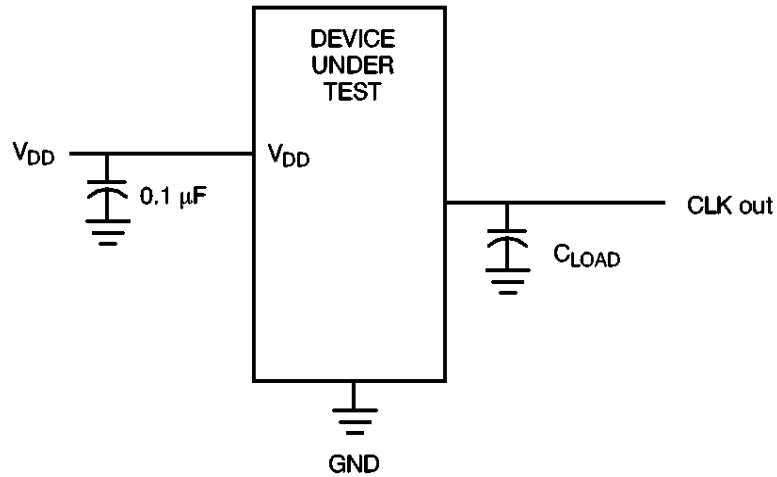

Ordering Information

Ordering Code	Package Name	Package Type	Operating Range
ICD2051	S1	16-Pin SOIC	Commercial ^[3]

Note:

3. 0°C to +70°C

Document #: 38-00402

Package Diagram

16-Lead Molded SOIC S1

