

**HIGH VOLTAGE IGNITION COIL DRIVER
POWER IC**

ADVANCE DATA

- NO EXTERNAL COMPONENT REQUIRED
- INTEGRATED HIGH VOLTAGE CLAMP
- COIL CURRENT LIMIT INTERNALLY SET
- HIGH RUGGEDNESS

DESCRIPTION

The VB921ZV and VB921ZVFI are monolithic high voltage integrated circuits made using SGS-THOMSON Microelectronics Vertical Intelligent Power Technology, which combines a vertical current flow power trilinton with a coil current limiting circuit and a collector voltage clamping.

The device is peculiarly suitable for application in high performance electronic car ignition, where coil current limitation and voltage clamping are required.

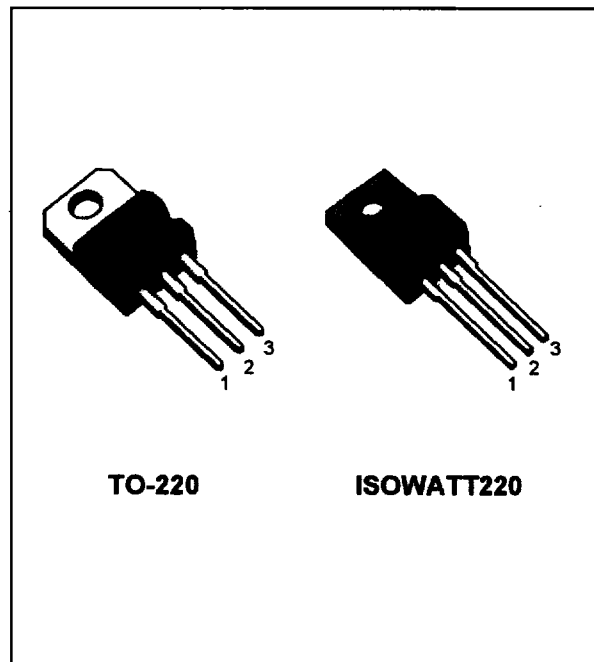

TO-220

ISOWATT220

INTERNAL SCHEMATIC DIAGRAM

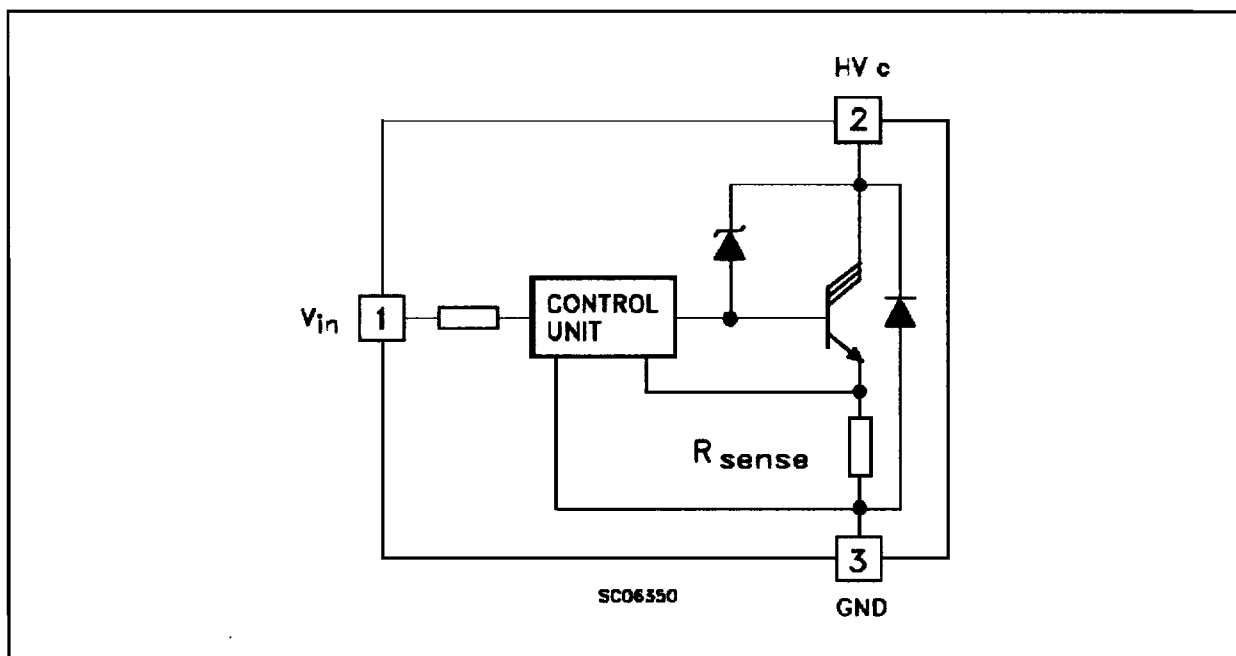

SGS15530

VB921ZV/ZVFI

ABSOLUTE MAXIMUM RATING

Symbol	Parameter	Value		Unit
		VB921Z	VB921ZFI	
HV_c	Collector Voltage	Internally Limited		V
V_{in}	Maximum Input Voltage	8		V
I_c	Collector Current	Internally Limited		A
I_{in}	Input Current	20		mA
P_{tot}	Total Dissipation at $T_c = 25\text{ }^\circ\text{C}$	100	40	W
T_{stg}	Storage Temperature	-40 to 150		$^\circ\text{C}$
T_j	Operating Junction Temperature	-40 to 150		$^\circ\text{C}$

THERMAL DATA

			TO-220	ISOWATT220	
$R_{thj-case}$	Thermal Resistance Junction-case	Max	1.25	3.12	$^\circ\text{C/W}$
$R_{thj-amb}$	Thermal Resistance Junction-ambient	Max	62.5		$^\circ\text{C/W}$

ELECTRICAL CHARACTERISTICS ($V_{batt} = 12\text{ V}$, $T_{case} = 25\text{ }^\circ\text{C}$ unless otherwise specified)

Symbol	Parameter	Test Conditions	Min.	Typ.	Max.	Unit
I_{cgo}	Collector Cut-off Current	$V_{in} = 0$ $HV_c = 250\text{ V}$			250	μA
V_{cl}^*	Clamping Voltage	$-40 < T_j < 125\text{ }^\circ\text{C}$	300		400	V
$V_{cg(sat)}$	Power Stage Saturation Voltage	$I_c = 6\text{ A}$ $I_{in} = 10\text{ mA}$			2.5	V
I_{cl}^*	Coil Current Limit	$V_{in} = 5\text{ V}$ $-40 \leq T_j \leq 125\text{ }^\circ\text{C}$ see note 1	6.5	7	7.5	A
I_{in}	Input Current		8			mA
V_f^{**}	Diode Forward Voltage	$I_f = 10\text{ A}$			2.5	V
V_{in}	Input Voltage		4.5		5.5	V
ΔI_{cl}	Coil Current Variation in Respect to $V_{in} = 5\text{ V}$	$V_{in} = 4.5 - 5.5\text{ V}$			200	mA

* Coil data: primary resistance $R_c = 0.4 - 0.8\ \Omega$, primary inductance $L_c = 6 - 8\text{ mH}$

** Pulsed: Pulse duration = $300\ \mu\text{s}$, duty cycle 1.5 %

NOTE 1: I_{cl} is also controlled in respect to the variation of V_{in} between 0.5 to 5.5 V

TO-220 MECHANICAL DATA

DIM.	mm			inch		
	MIN.	TYP.	MAX.	MIN.	TYP.	MAX.
A	4.40		4.60	0.173		0.181
C	1.23		1.32	0.048		0.051
D	2.40		2.72	0.094		0.107
D1		1.27			0.050	
E	0.49		0.70	0.019		0.027
F	0.61		0.88	0.024		0.034
F1	1.14		1.70	0.044		0.067
F2	1.14		1.70	0.044		0.067
G	4.95		5.15	0.194		0.203
G1	2.4		2.7	0.094		0.106
H2	10.0		10.40	0.393		0.409
L2		16.4			0.645	
L4	13.0		14.0	0.511		0.551
L5	2.65		2.95	0.104		0.116
L6	15.25		15.75	0.600		0.620
L7	6.2		6.6	0.244		0.260
L9	3.5		3.93	0.137		0.154
DIA.	3.75		3.85	0.147		0.151

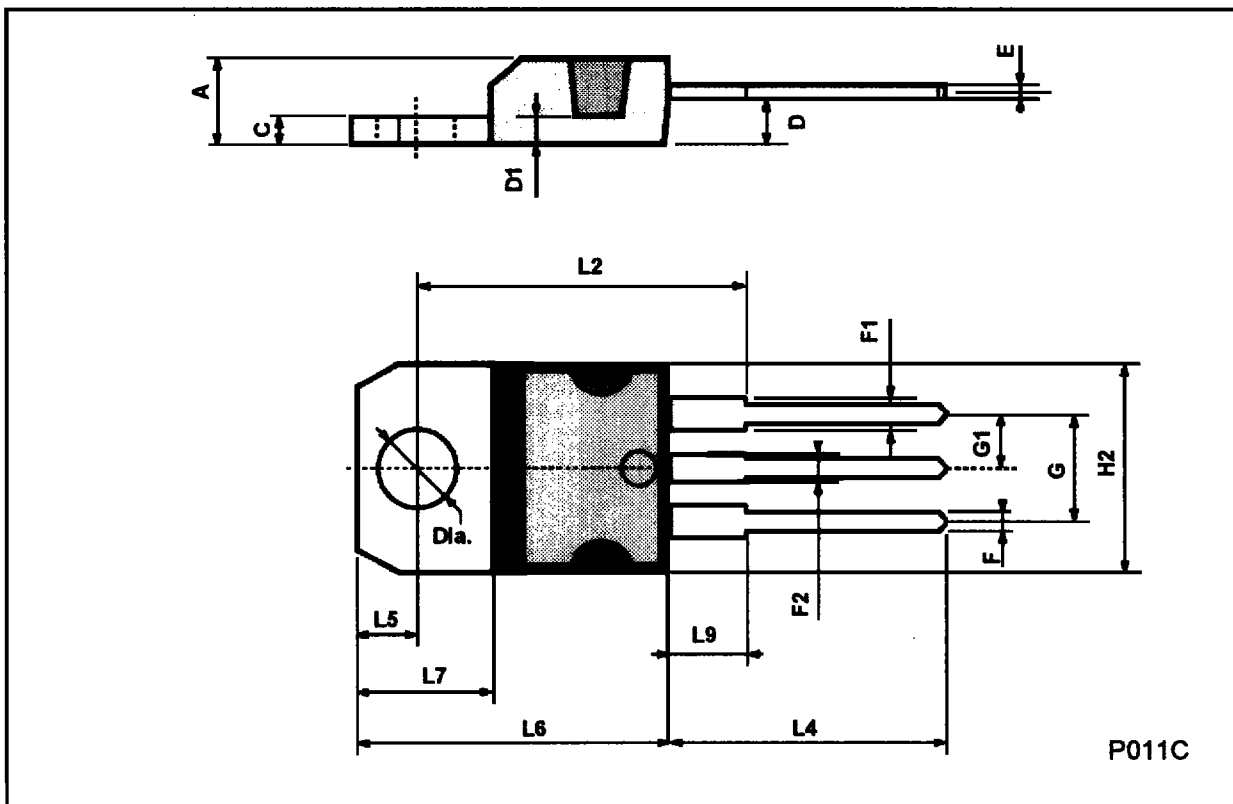

10 WATT220 MECHANICAL DIMS

DIM.	mm			inch		
	MIN.	TYP.	MAX.	MIN.	TYP.	MAX.
A	4.4		4.6	0.173		0.181
B	2.5		2.7	0.098		0.106
D	2.5		2.75	0.098		0.108
E	0.4		0.7	0.015		0.027
F	0.75		1	0.030		0.039
F1	1.15		1.7	0.045		0.067
F2	1.15		1.7	0.045		0.067
G	4.95		5.2	0.195		0.204
G1	2.4		2.7	0.094		0.106
H	10		10.4	0.393		0.409
L2		16			0.630	
L3	28.6		30.6	1.126		1.204
L4	9.8		10.6	0.385		0.417
L6	15.9		16.4	0.626		0.645
L7	9		9.3	0.354		0.366
∅	3		3.2	0.118		0.126

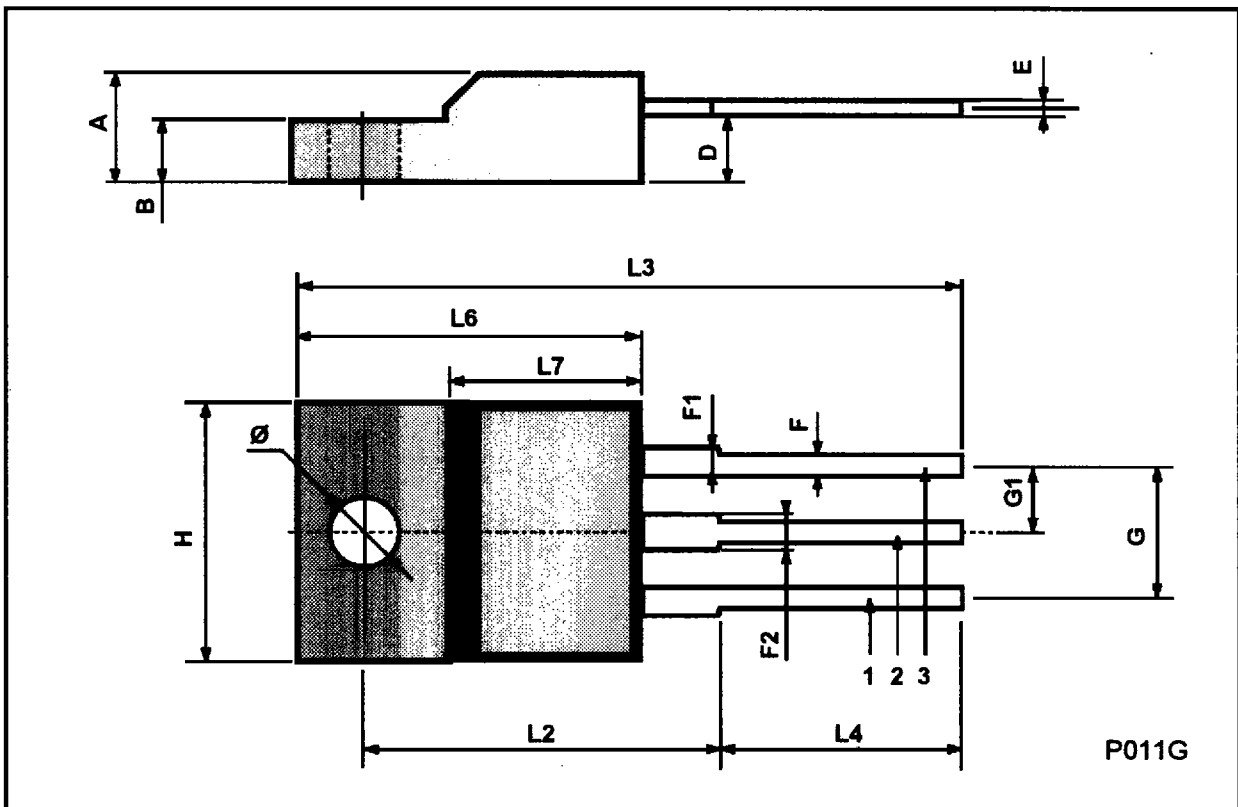

Information furnished is believed to be accurate and reliable. However, SGS-THOMSON Microelectronics assumes no responsibility for the consequences of use of such information nor for any infringement of patents or other rights of third parties which may result from its use. No license is granted by implication or otherwise under any patent or patent rights of SGS-THOMSON Microelectronics. Specifications mentioned in this publication are subject to change without notice. This publication supersedes and replaces all information previously supplied. SGS-THOMSON Microelectronics products are not authorized for use as critical components in life support devices or systems without express written approval of SGS-THOMSON Microelectronics.

© 1994 SGS-THOMSON Microelectronics - All Rights Reserved

SGS-THOMSON Microelectronics GROUP OF COMPANIES

Australia - Brazil - France - Germany - Hong Kong - Italy - Japan - Korea - Malaysia - Malta - Morocco - The Netherlands -
Singapore - Spain - Sweden - Switzerland - Taiwan - Thailand - United Kingdom - U.S.A