

General Description

The MAX31740 is a sophisticated, yet easy-to-use fan-speed controller. It monitors the temperature of an external NTC thermistor and generates a PWM signal that can be used to control the speed of a 2-, 3-, or 4-wire fan. The fan control characteristics are set using external resistors, thereby eliminating the need for an external microcontroller. Controllable characteristics include the starting temperature for fan control, PWM frequency, fan speed at low temperatures, and slope of the temperature-duty-cycle transfer function.

Because the operating characteristics are selected by hardwired passive components, a simple, low-cost fan-speed controller can be implemented without the need for firmware development. This can dramatically reduce development time for the fan control function.

The MAX31740 is available in a 2mm x 3mm, 8-pin TDFN package.

Features

- Self-Contained PWM Fan Control—No Micro Needed
- Controls Speed of 2-, 3-, or 4-Wire Fans
- Resistors Set Fan Control Characteristics
- Smooth, Linearly Varying PWM Duty Cycle Minimizes Audibility of Fan Noise
- Accurately Monitors External Thermistor Temperature
- 3.0V to 5.5V Operating Voltage Range
- -40°C to +125°C Operating Temperature Range

Applications

- Consumer Equipment
- Communications Equipment
- Computing Equipment
- Industrial Equipment

Ordering Information appears at end of data sheet.

Typical Application Circuits

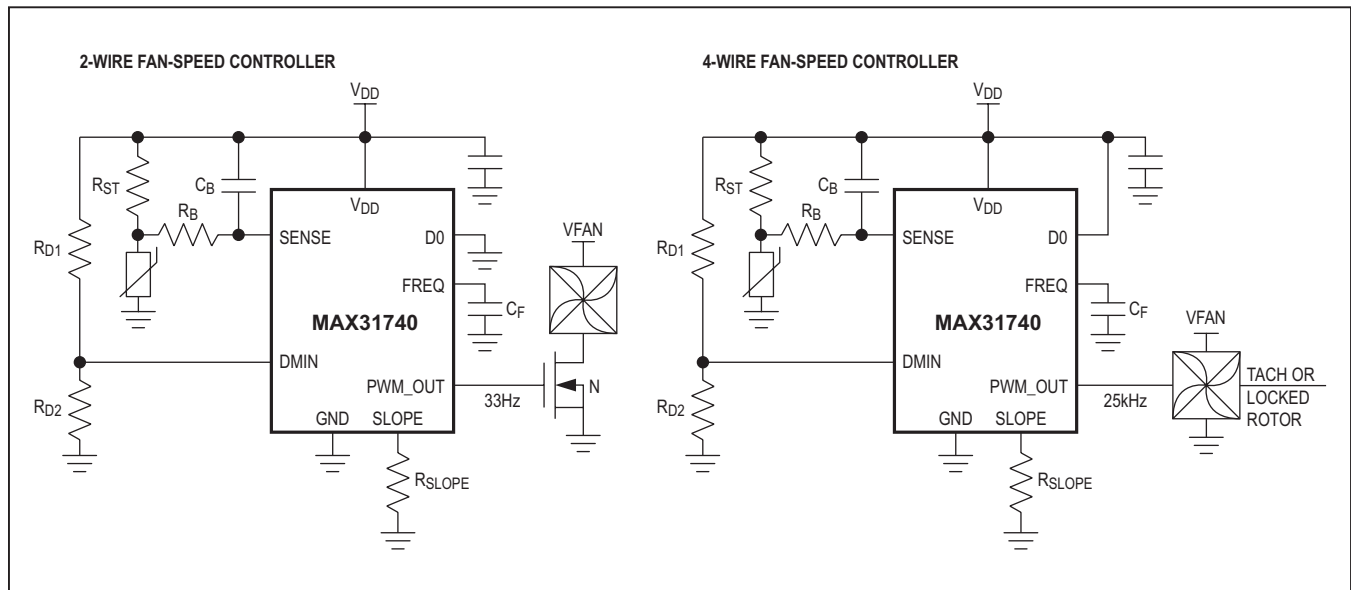

For related parts and recommended products to use with this part, refer to www.maximintegrated.com/MAX31740.related.

Absolute Maximum Ratings

(All voltages relative to ground.)

Voltage Range on V_{DD} -0.3V to +6.0V
 Voltage Range on Any Non-Power Pin -0.3V to (V_{DD} + 0.3V)
 Operating Temperature Range -40°C to +125°C

Storage Temperature Range -55°C to +125°C
 Junction Temperature Maximum +150°C
 Soldering Temperature (reflow) +260°C

Stresses beyond those listed under "Absolute Maximum Ratings" may cause permanent damage to the device. These are stress ratings only, and functional operation of the device at these or any other conditions beyond those indicated in the operational sections of the specifications is not implied. Exposure to absolute maximum rating conditions for extended periods may affect device reliability.

Package Thermal Characteristics (Note 1)

TDFN

Junction-to-Ambient Thermal Resistance (θ_{JA}) 60°C/W
 Junction-to-Case Thermal Resistance (θ_{JC}) 11°C/W

Note 1: Package thermal resistances were obtained using the method described in JEDEC specification JESD51-7, using a four-layer board. For detailed information on package thermal considerations, refer to www.maximintegrated.com/thermal-tutorial.

Recommended Operating Conditions

(T_A = -40°C to +125°C, unless otherwise noted.) (Note 2)

PARAMETER	SYMBOL	CONDITIONS	MIN	TYP	MAX	UNITS
Supply Voltage	V _{DD}		3.0	3.3	5.5	V
Logic 1 (D0)	V _{IH}		V _{DD} × 0.7		V _{DD} + 0.3	V
Logic 0 (D0)	V _{IL}		-0.3		V _{DD} × 0.3	V

Electrical Characteristics

(V_{DD} = V_{DDMIN} to V_{DDMAX}, T_A = -40°C to +125°C, unless otherwise noted.) (Notes 2, 3)

PARAMETER	SYMBOL	CONDITIONS	MIN	TYP	MAX	UNITS
Supply Current (Note 4)	I _{DD}	V _{DD} = 3.3V		500	800	µA
		V _{DD} = 5.5V		750	1100	
PWM Start Voltage (Note 5)	V _{START}	V _{DD} = 3.3V	-80	-40	+10	mV
Input Bias Current (SENSE)	I _{BIAS}	T _A = +25°C to +125°C		19		nA
Internal DO Pulldown Resistor	DORLOAD		20	60	100	kΩ
Internal SLOPE Feedback Resistance (Note 6)	R _{FBK}	V _{DD} = 3.3V, T _A = +25°C		22 ± 2.4		kΩ
Sawtooth Peak Voltage Offset (Note 7)	V _{FSOFFSET}			±12		mV
Sawtooth Peak Voltage	V _{FS}		0.4925	0.5	0.5075	x V _{DD}
R _{SLOPE} Capacitive Load (Note 8)	C _{SLOPE}				10	pF
PWM Output Low	V _{OL}	I _{SINK} = 6mA			0.4	V
PWM Output High	V _{oH}	I _{SOURCE} = -6mA	V _{DD} - 0.4			V
PWM Frequency	PWM _{FREQ}			10.5455 ⁻⁶ /C _F		Hz
		T _A = +25°C to +125°C	-10		+10	%
		T _A = -40°C to +125°C	-20		+20	

Capacitance

($T_A = +25^\circ\text{C}$, unless otherwise noted.)

PARAMETER	SYMBOL	CONDITIONS	MIN	TYP	MAX	UNITS
Input Capacitance	C_I	(Note 9)		10		pF
Output Capacitance	C_O	(Note 9)		15		pF

Note 2: All voltages referenced to ground.

Note 3: Limits are production tested at $T_A = +25^\circ\text{C}$. Limits over the operating temperature range and relevant supply voltage range are guaranteed by design and characterization. Typical values are not guaranteed.

Note 4: $\text{SENSE} = V_{DD}/2$.

Note 5: V_{START} specifies the voltage change relative to $V_{DD}/2$ that is required to start PWM. Negative value indicates lower than $V_{DD}/2$.

Note 6: The typical (TYP) column indicates ± 3 sigma distribution of a trimmed resistance.

Note 7: V_{FSOFFSET} is specified relative to $V_{DD}/2$. The total error equals $V_{\text{FS}} + V_{\text{FSOFFSET}}$.

Note 8: For stable PWM operation, the maximum external capacitance connected to R_{SLOPE} from all sources must be less than 10pF.

Note 9: Guaranteed by design; not 100% production tested.

Typical Operating Characteristics

(TA = +25°C, unless otherwise noted.)

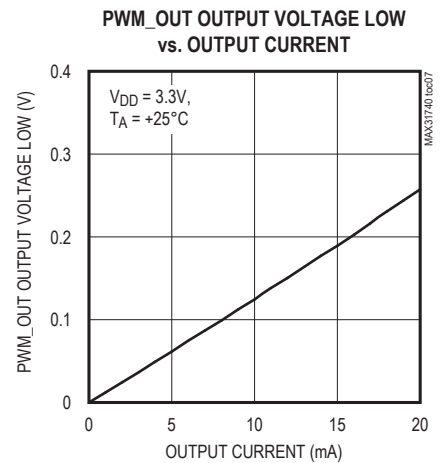
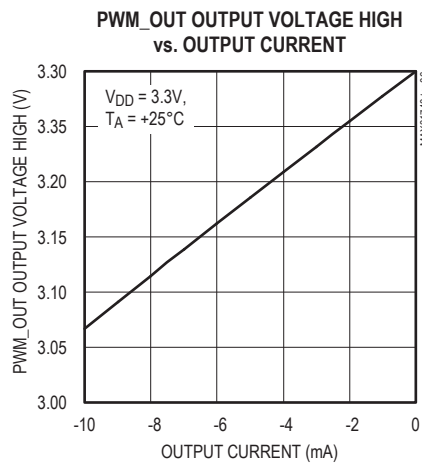
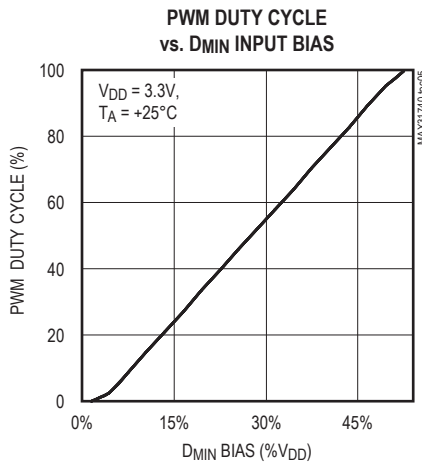
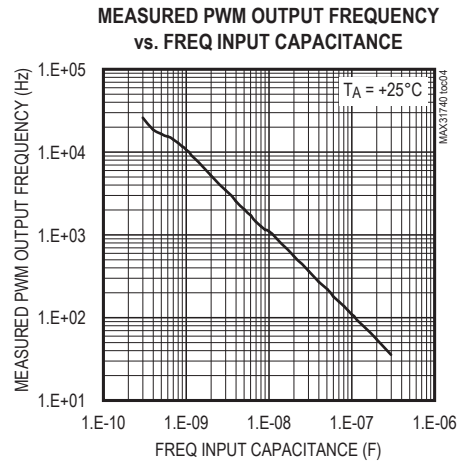
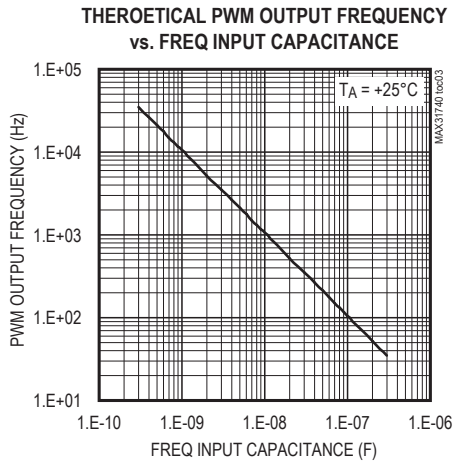
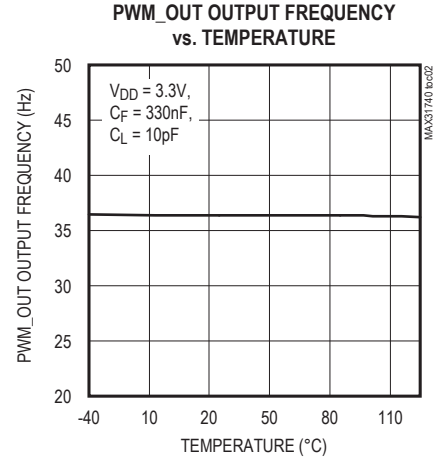
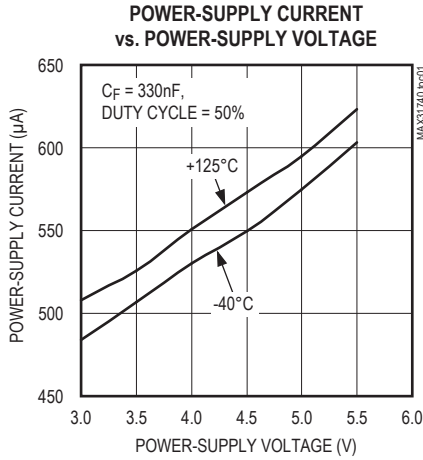

Pin Configuration

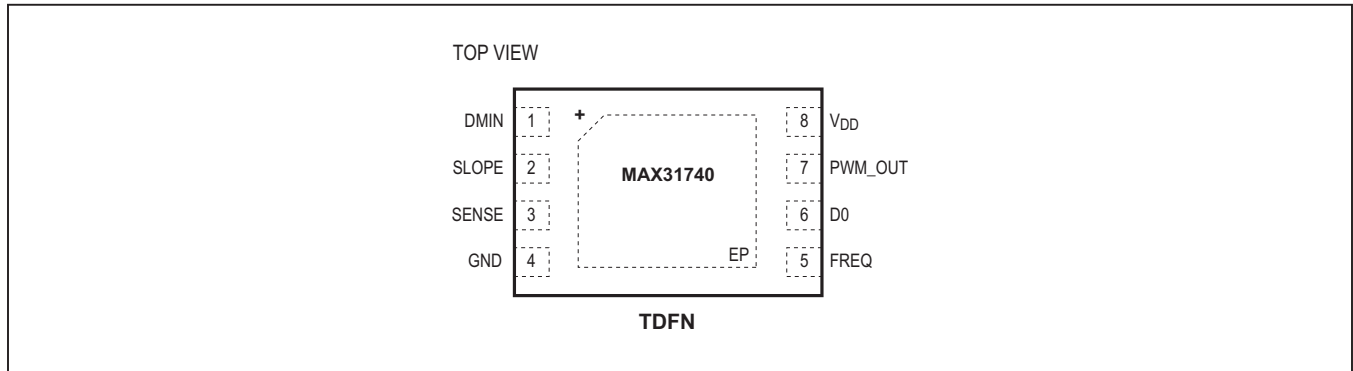

Pin Description

PIN	NAME	FUNCTION
1	DMIN	Connect to an external resistor divider to set the minimum active PWM duty cycle. (Typically between $0.05V_{DD}$ to $0.2V_{DD}$ depending on desired minimum duty cycle.)
2	SLOPE	Connect to an external resistor to set the slope of the temperature-PWM curve.
3	SENSE	Thermistor Voltage Input. External NTC thermistor senses temperature. Thermistor and external resistor form a voltage divider with a negative temperature coefficient.
4	GND	Ground
5	FREQ	Connect to external capacitor C_F to set PWM frequency.
6	D0	Duty Cycle Input. Sets the duty cycle below t_{MIN} to either D_{MIN} or 0%. Connect to GND for 0% or to V_{DD} for D_{MIN} . D0 has an internal $60k\Omega$ (typ) pulldown resistor.
7	PWM_OUT	PWM CMOS output signal.
8	V_{DD}	3.0V to 5.5V Supply Voltage Input. Bypass with at least a $0.01\mu F$ capacitor.
—	EP	Exposed Pad. Connect to ground, but do not use as the sole ground connection point or leave unconnected.

Block Diagram

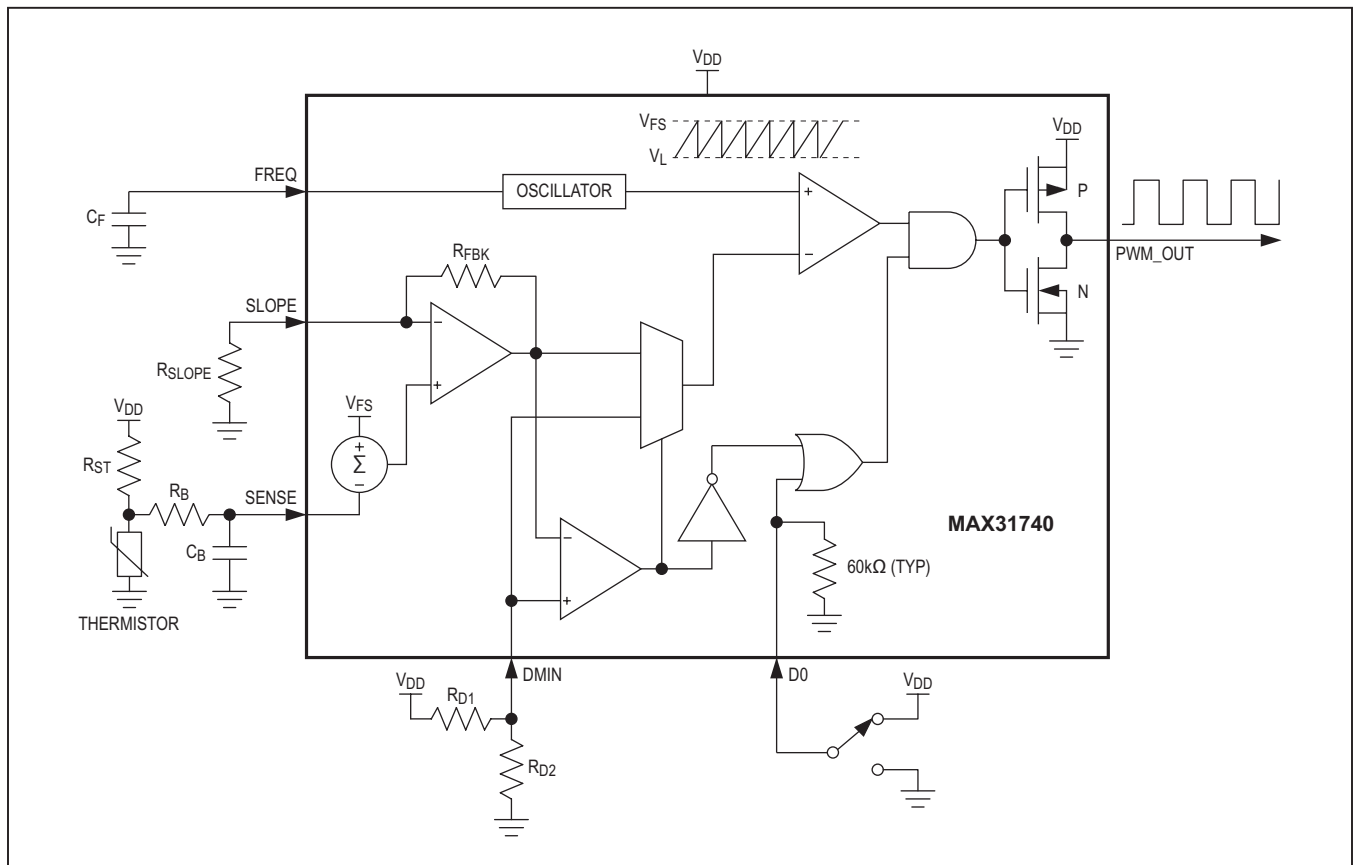

Detailed Description

The MAX31740 monitors the temperature of an external NTC thermistor and generates a PWM signal that can be used to control the speed of a 2-, 3-, or 4-wire fan. The fan control characteristics are set using external resistors and capacitors, thereby eliminating the need for an external microcontroller. Controllable characteristics include the starting temperature for fan control, PWM frequency, fan speed at low temperatures, and slope of the temperature-duty-cycle transfer function.

Controlling Fan Speed

The device generates a PWM signal and varies the duty cycle of that signal to control the speed of one or more fans. If the fan has a PWM speed control input (typically this is a “4-wire” fan), the recommended PWM frequency is usually in the 20kHz to 30kHz range.

PWM_OUT is a CMOS output that can be connected directly to most fans’ speed control input as shown in the 4-Wire Fan-Speed Controller [Typical Application Circuits](#).

If the fan has no speed control input (this is the case for all 2-wire fans and most 3-wire fans), there are two options for controlling the fan’s speed. The first option is to use a low-frequency (typically 33Hz) PWM signal to modulate the fan’s power supply as shown in the 2-Wire Fan-Speed Controller [Typical Application Circuits](#).

The advantage of using PWM to modulate the fan’s power supply is that it is inexpensive. Note, however, that some fan manufacturers recommend against this approach for their fans. Before using this approach, be sure to verify that the fan is compatible with pulse-width modulation of the power supply. Also, modulating the power-supply voltage in this manner can cause an increase in the perceived noise level when the duty cycle is not equal to 100% or 0%.

Another option for fans with no speed control input is to convert the PWM signal to a DC voltage. This can be done using a simple two-transistor buffer circuit, a linear low-dropout voltage regulator, or a switch-mode voltage regulator. Always use a high PWM frequency (20kHz or higher recommended) in this case to ease filtering. [Figure 1](#) shows an example of a two-transistor buffer circuit.

Fan Control Profile

[Figure 2](#) shows three general curves of PWM duty cycle vs. temperature for the device. The important parameters are listed as follows:

- **T_{START}** is the temperature that corresponds to the intersection of the diagonal portion of the curve, including the dashed portion in (b) and (c), with 0% duty cycle. It is selected by setting resistor R_{ST} equal to the resistance of the thermistor at temperature T_{START}.
- **D_{MIN}** is the PWM duty cycle at the lower left end of the solid diagonal portion of the curve. It is selected using a resistor-divider to set the voltage at the DMIN input.
- **T_{MIN}** is the temperature at which the duty cycle begins to increase from D_{MIN}.
- **D₀** is the value of the PWM duty cycle for temperatures below T_{MIN}. This value is equal to either D_{MIN} or 0% in curves (b) and (c), depending upon whether D₀ is connected to V_{DD} or GND.
- The **slope** of the diagonal portion of the curve is selected by the value of the resistor at the SLOPE input.

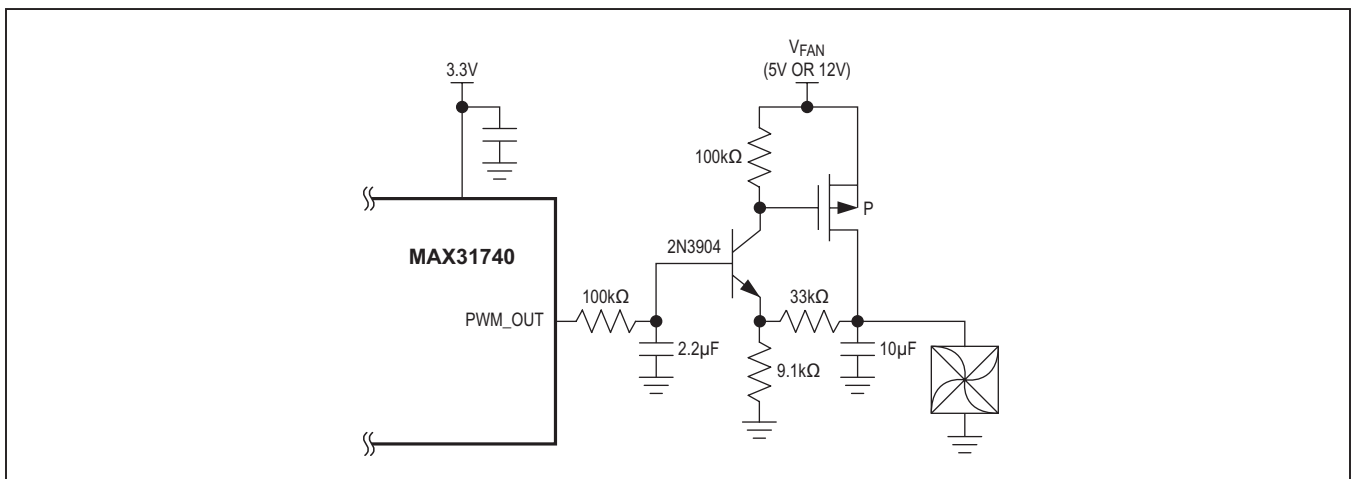

Figure 1. Two-Transistor Buffer

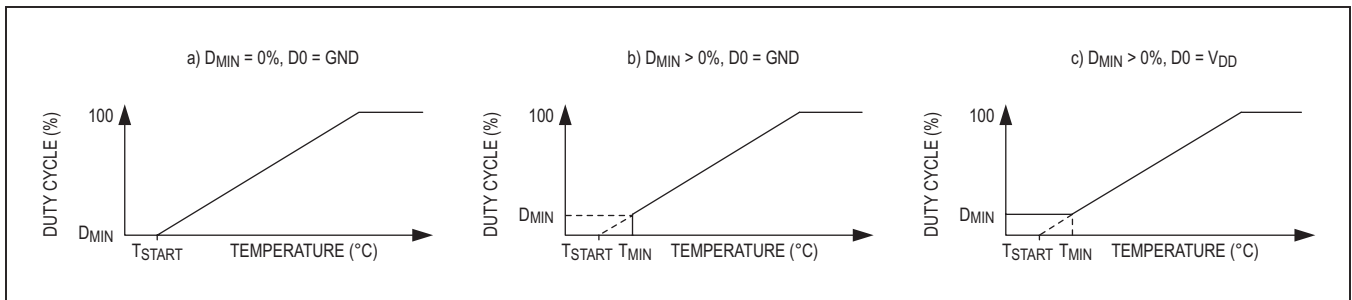

Figure 2. PWM Duty Cycle vs. Temperature

Operation

Referring to the Block Diagram, C_F sets the frequency of the internal saw-tooth oscillator that is used to generate the PWM speed control signal. The oscillator's output voltage swings from near-zero to V_{FS} ($V_{DD}/2$).

The external NTC thermistor and resistor (R_{ST}) form a voltage-divider whose output voltage is approximately linear and has a negative temperature coefficient. This voltage is subtracted from V_{FS} to create a voltage with a positive temperature coefficient at the input to the amplifier. The amplifier's closed-loop gain is set by an external resistor (R_{SLOPE}) and an internal 25k Ω resistor (R_{FBK}). The value of R_{SLOPE} therefore determines the slope of the duty cycle as a function of temperature. The temperature at which the thermistor's resistance is equal to R_{ST} is the nominal value of T_{START} .

The voltage at D_{MIN} , derived by the voltage-divider between V_{DD} and GND, determines the minimum duty cycle. The logic level at $D0$ determines whether the low-temperature duty cycle will be 0% or equal to D_{MIN} .

Component Selection

Before picking component values, be sure that you have determined target values for the important parameters such as PWM frequency, T_{START} , D_{MIN} , $D0$, and the Slope of the duty cycle vs. temperature curve. Most of these parameters are defined in the [Fan Control Profile](#) section.

PWM Frequency

If the fan has a speed control input, the most common recommended PWM frequency is 25kHz, although some fans require different frequencies. If the fan has no PWM input and will be controlled by applying the PWM signal directly to a power-supply modulation transistor (as in the typical 2-wire fan-speed controller circuit), the PWM frequency should normally be in the 25Hz to 35Hz range. A good starting point is 33Hz.

C_F sets the PWM frequency according to the equation:

$$C_F = 10.5455E^{-6}/FREQ \text{ (Hz)}$$

The most common values of C_F are 330nF for $f_{PWM} = 33\text{Hz}$ and 430pF for $f_{PWM} = 25\text{kHz}$.

T_{START}

Select R_{ST} equal to the resistance of the thermistor at the desired value of T_{START} .

D_{MIN} and $D0$

Select D_{MIN} and $D0$ based on the system requirements and the type of fan to be used. For example, in some systems, the optimum cooling strategy requires that the fan stop spinning when the temperature is below a specific value (T_{MIN}). Such a scheme can be achieved with the fan profile shown in [Figure 2\(c\)](#). The voltage V_{MIN} at the D_{MIN} input selects the minimum duty cycle using the following equation:

$$V_{MIN}/V_{DD} = R2/(R1+R2) = D_{MIN} \text{ (%)}/200$$

where D_{MIN} is the minimum duty cycle (in percent).

For example, if a minimum duty cycle of 30% is desired, the voltage at the D_{MIN} input should be 15% of V_{DD} .

When the temperature drops below T_{MIN} in the profile shown in [Figure 2\(b\)](#), the duty cycle should drop to zero. This is accomplished by connecting the $D0$ input to GND.

If the system requires a profile like the one in [Figure 2\(c\)](#), where the duty cycle remains at D_{MIN} when the temperature drops below T_{MIN} , simply connect $D0$ to V_{DD} .

Some fans with speed control inputs (these are typically 4-wire fans) are designed to keep spinning at a reduced speed even when the duty cycle is equal to zero. For such fans, a profile like that of [Figure 2\(a\)](#) is usually appropriate. With this profile, the duty cycle decreases linearly to zero as temperature decreases. To achieve this profile, connect $D0$ to GND.

Thermistor

Use a standard NTC thermistor. A +25°C resistance in the 10k Ω to 50k Ω range works well. An NTC's resistance-temperature curve is generally very nonlinear, but when combined with R_{ST} in a voltage-divider, the resulting curve is reasonably linear over the temperature range of interest.

R_{ST}

First determine T_{START} . In [Figure 2\(a\)](#), T_{START} is the temperature at which the duty-cycle curve intersects the horizontal axis. In [Figure 2\(b\)](#) and [Figure 2\(c\)](#), T_{START} can be determined by continuing the diagonal line until it crosses the horizontal axis, and the point at which it intersects the horizontal axis is T_{START} . Now choose R_{ST} equal to the resistance of the thermistor at T_{START} .

Slope

R_{SLOPE} sets the slope of the duty cycle vs. temperature curve. Pick the value based on the thermistor characteristics and the desired range of temperatures between T_{MIN} and the point where the duty cycle reaches 100%.

As an example, assume that a typical NTC thermistor + R_{ST} combination will provide a slope of about 1% of V_{DD} per °C. Since $V_{FS} = V_{DD}/2$, this is equivalent to 2% of V_{FS} per °C at the input to the internal amplifier. Therefore, the range of duty cycles from 0% to 100% would correspond to about a 50°C range of temperatures when the amplifier gain is equal to one. In most implementations, you would want a smaller temperature range (for example, 15°C) to cause the duty cycle to cover the full 0% to 100% range. Doing so requires an amplifier gain of:

$$A_V = 50^\circ\text{C}/15^\circ\text{C} = 3.33$$

The closed-loop gain of the internal amplifier is:

$$A_V = (1 + R_{FBK}/R_{SLOPE}).$$

Therefore:

$$R_{SLOPE} = R_{FBK}/(A_V - 1) = 25\text{k}\Omega/(3.33 - 1) = 10.7\text{k}\Omega$$

R_{ST} and R_{SLOPE} Example Values

Table 1 gives example values of R_{ST} and R_{SLOPE} for three values of T_{START} and three fan control temperature spans. Values are given for two standard thermistor products, one rated at 10kΩ and the other rated at 15kΩ at +25°C.

C_B and R_B

One of the most common reasons for controlling fan speed is to reduce the audible noise perceived by users in the vicinity of the equipment. The audibility of fan noise increases significantly when the fan speed undergoes rapid changes. When the thermistor is in contact with a significant mass, such as a heat sink or a printed circuit board, the thermal mass of the object being measured will often limit the rate of change of the voltage at the SENSE input so that any fan speed changes are slow and no additional filtering is needed. In such cases, R_B and C_B are not necessary.

In some cases, the thermistor could be in contact with an object whose temperature changes relatively rapidly, or a low-mass thermistor can be suspended in an area where air flow could cause its temperature to undergo

Table 1. R_{ST} and R_{SLOPE} Resistor Options

THERMISTOR	T_{START}	R_{ST} (kΩ)	CONTROL RANGE (T_{START} to $T_{100\%}$)	R_{SLOPE} (kΩ)
BetaTHERM 10K3A1	25	10	+10°C	6.65
			+15°C	11
			+20°C	16.2
	30	8.06	+10°C	6.49
			+15°C	10.5
			+20°C	15.4
	35	6.49	+10°C	6.04
			+15°C	10
			+20°C	14.7
Murata NCP15XW153J03RC	25	15	+10°C	5.49
			+15°C	8.87
			+20°C	13
	30	12.4	+10°C	5.23
			+15°C	8.45
			+20°C	12.4
	35	10.5	+10°C	5.36
			+15°C	8.45
			+20°C	12.4

fast changes. In these cases, the temperature changes can be fast enough to cause audible fan speed variations. To minimize this effect, the rate at which the duty cycle can change can be slowed down using an external RC network consisting of R_B and C_B and connected to the SENSE input. Typical values for these components are $5M\Omega$ and $1\mu F$, although they can be easily adjusted to conform to the requirements of the system.

C_B can be connected to GND, V_{DD} , or an intermediate voltage depending on the desired startup characteristics. When connected to V_{DD} , C_B initially holds the SENSE input high upon application of V_{DD} , which delays the onset of the PWM signal when D0 is grounded and the temperature on application of V_{DD} is greater than T_{START} . The delay time is related to the time constant $C_B R_B$. When connected to GND, C_B briefly keeps the SENSE input low upon application of V_{DD} , providing a “spin-up” function on power-up that can be useful in some cases (but is generally not necessary). Connecting C_B to a voltage-divider that produces an output of $V_{DD}/2$ can be used to minimize any spin-up or delay time.

Ordering Information

PART	TEMP RANGE	PIN-PACKAGE
MAX31740ATA+	-40°C to +125°C	8 TDFN-EP*

+Denotes a lead(Pb)-free/RoHS-compliant package.

*EP = Exposed pad.

Chip Information

SUBSTRATE CONNECTED TO GROUND

PROCESS: CMOS

Applications Information

Power-Supply Decoupling

To achieve the best results when using the device, decouple the V_{DD} power supply with a (minimum) $0.01\mu F$ capacitor. Use a high-quality, ceramic, surface-mount capacitor if possible. Surface-mount components minimize lead inductance, which improves performance, and ceramic capacitors tend to have adequate high-frequency response for decoupling applications.

Handling, PCB Layout, and Assembly

The lead-free/RoHS package can be soldered using a reflow profile that complies with JEDEC J-STD-020.

Moisture-sensitive packages are shipped from the factory dry-packed. Handling instructions listed on the package label must be followed to prevent damage during reflow. Refer to the IPC/JEDEC J-STD-020 standard for moisture-sensitive device (MSD) classifications.

Package Information

For the latest package outline information and land patterns (footprints), go to www.maximintegrated.com/packages. Note that a “+”, “#”, or “-” in the package code indicates RoHS status only. Package drawings may show a different suffix character, but the drawing pertains to the package regardless of RoHS status.

PACKAGE TYPE	PACKAGE CODE	OUTLINE NO.	LAND PATTERN NO.
8 TDFN-EP	T823+1	21-0174	90-0091

Revision History

REVISION NUMBER	REVISION DATE	DESCRIPTION	PAGES CHANGED
0	5/13	Initial release	—

For pricing, delivery, and ordering information, please contact Maxim Direct at 1-888-629-4642, or visit Maxim's website at www.maximintegrated.com.

Maxim Integrated cannot assume responsibility for use of any circuitry other than circuitry entirely embodied in a Maxim Integrated product. No circuit patent licenses are implied. Maxim Integrated reserves the right to change the circuitry and specifications without notice at any time. The parametric values (min and max limits) shown in the Electrical Characteristics table are guaranteed. Other parametric values quoted in this data sheet are provided for guidance.