

Fast Recovery/Schottky Diodes

Product Line Card

Fast Recovery Diodes (FRDs)

Fairchild's broad portfolio of Fast Recovery Diodes has been specifically designed to address Ultra Fast Soft Recovery, high-speed and high-voltage design requirements for power switching applications.

Applications include:

- Power Switching Circuits
- Switching Mode Power Supply
- Freewheeling Diodes
- Damper & Modulation Diode
- Power Factor Correction
- RCD Snubber Circuits

Schottky Barrier Diodes (SBDs)

Fairchild's Schottky Barrier Diodes feature low power loss and high-speed rectification characteristics for applications where power saving is crucial. Choose from our SBD product family for all your battery driven designs such as cellular phones, pagers and portable PCs.

Applications include:

- Output Rectifiers

Family Specification Comparison

Fast Recovery Diodes (FRDs)

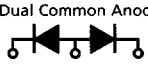
Chip Connection	Part Number	$V_{RRM}(V)$	$I_{F(AV)}(A)$	$V_{F(MAX)}(V)$	$t_{rr(MAX)}(ns)$	Package
 Single	FFPF06U20S	200	6	1.2	35	TO-220F
	FFPF10U20S		10	1.2	35	
	FFPF15U20S		15	1.2	40	
	FFPF20U20S		20	1.2	40	
	FFPF30U20S		30	1.2	40	
	FFPF04U40S	400	4	1.4	45	
	FFPF06U40S		6	1.4	50	
	FFPF10U40S		10	1.4	50	
	FFPF15U40S	15	1.4	50		
	FFPF20U40S	20	1.4	50		
	FFPF05U60S	600	5	2.3	80	
	FFPF10U60S		10	2.2	90	
	FFPF20U60S		20	2.2	90	
	FFPF30U60S	30	2.3	90		
	FFPF40U60S	40	2.1	110		
FFPF05U120S	1200	5	3.5	100		
FFPF10U120S		10	3.5	100		
FFPF15U120S		15	3.5	100		
FFB05U120S	1200	5	3.5	100	D ² -PAK	
FFB10U120S		10	3.5	100		
 Dual Common Anode	FFPF06U20DP	200	6	1.2	35	TO-220F
	FFPF10U20DP		10	1.2	35	
	FFPF15U20DP		15	1.2	40	
	FFPF04U40DP	400	4	1.4	45	
	FFPF06U40DP		6	1.4	50	

Note 1) *In development 2) V_F , I_F , rated per diode, at $T_C = 25^\circ C$ & each $I_{F(AV)}$ 3) t_{rr} condition of measurements: Each $I_{F(AV)}$ and $di/dt = 200A/\mu s$

Continued on next page →

FAIRCHILD
SEMICONDUCTOR™

Family Specification Comparison (continued)

Fast Recovery Diodes (FRDs continued)

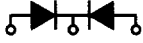
Chip Connection	Part Number	V _{RRM} (V)	I _{F(AV)} (A)	V _{F(MAX)} (V)	t _{rr(MAX)} (ns)	Package	
 Dual Common Cathode	FFPF06U20DN	200	6	1.2	35	TO-220F	
	FFPF10U20DN		10	1.2	35		
	FFPF15U20DN		15	1.2	40		
	FFPF04U40DN	400	4	1.4	45		
	FFPF06U40DN		6	1.4	50		
	FFPF05U60DN	600	5	2.3	80		
	FFPF10U60DN		10	2.2	90		
	FFPF20U60DN		20	2.2	90		
	FFPF30U60DN		30	2.3	90		
	FFP06U20DN	200	6	1.2	35		TO-220
	FFP10U20DN		10	1.2	35		
	FFP15U20DN		15	1.2	40		
	FFP04U40DN	400	4	1.4	45		
	FFP06U40DN		6	1.4	50		
	FFP05U60DN	600	5	2.3	80		
	FFP10U60DN		10	2.2	90		
	FFP20U60DN		20	2.2	90		
	FFP30U60DN		30	2.3	90		
	FFAF15U20DN	200	15	1.2	40	TO-3PF	
	FFAF20U20DN		20	1.2	40		
	FFAF10U40DN	400	10	1.4	50		
	FFAF30U60DN		30	2.3	90		
	FFAF40U60DN	600	40	2.1	110		
	FFAF60U60DN		60	2.2	110		
	FFAF05U120DN	1200	5	3.5	100		
	FFAF10U120DN		10	3.5	100		
	FFAF15U120DN		15	3.5	100		
	FFAF20U120DN		20	3.5	120		
FFA15U20DN	200	15	1.2	40	TO-3P		
FFA20U20DN		20	1.2	40			
FFA30U20DN		30	1.2	40			
FFA10U40DN	400	10	1.4	50			
FFA15U40DN		15	1.4	50			
FFA20U40DN	600	20	1.4	50			
FFA30U60DN		30	2.3	90			
FFA40U60DN		40	2.1	110			
FFA60U60DN		60	2.2	110			
FFA05U120DN	1200	5	3.5	100			
FFA10U120DN		10	3.5	100			
FFA15U120DN		15	3.5	100			
FFA20U120DN		20	3.5	120			
FFL60U60DN	600	60	2.2	110	TO-264		
FFL20U120DN	1200	20	3.5	120			
FFL25U120DN		25	3.5	120			

Notes 1) *In development 2) V_F, I_F, rated per diode, at T_C = 25°C & each I_{F(AV)} 3) t_{rr} condition of measurements: Each I_{F(AV)} and di/dt = 200A/μs

Damper Diodes and Damper & Modulation Diodes

Chip Connection	Part Number	V _{RRM} (V)	I _{F(AV)} (A)	V _{F(MAX)} (V)	t _{rr(MAX)} (ns)	Package	
 Single	FFPF04F150S	1500	4	1.6	170	TO-220F	
	FFPF04U150S			1.8	150		
	FFPF06F150S			6	1.6		170
	FFPF06U150S				1.8		150
	FFPF10F150S			10	1.6		170
	FFPF10U150S				1.8		150
	FFPF14U150S			14	1.8		150
	FFPF14X150S				2.4		120
	FFPF05U170S*	1700	5	1.8	150		
Dual Series	FFAF60A150DS	600, 1500	20, 6	2.2, 1.6	90, 170	TO-3PF	

Notes 1) *In development 2) V_F, I_F, rated per diode, at T_C = 25°C & each I_{F(AV)} 3) t_{rr} condition of measurements: I_F=1A and di/dt = 50A/μs for damper diode; I_F=20A and di/dt = 200A/μs for modulation diode

Schottky Barrier Diodes (SBDs)

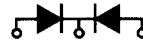
Chip Connection	Part Number	V _{RRM} (V)	I _O (A)	I _{rr(MAX)} (mA)	I _{FSM} (A)	V _{F(MAX)} (V)	Package
 Dual Common Cathode	FYPF1004DN*	40	10	3.5	80	0.55	TO-220F
	FYPF1504DN*		15	5	100	0.55	
	FYPF2004DN*		20	5	150	0.55	
	FYAF3004DN*	40	30	10	300	0.55	TO-3PF
	FYPF2006DN	60	20	8	200	0.58	TO-220F
	FYPF1010DN	100	10	3	100	0.75	

Note 1) *In development 2) I_{rr}, V_F, rated per diode, at T_C = 25°C and each I_{F(AV)} 3) I_{FSM} measurement condition: 60Hz single half sine-wave

Applications for SMPS

Single Flyback Type

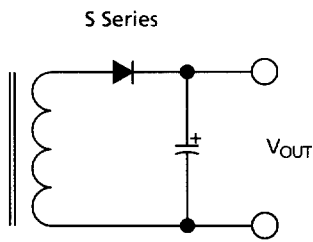

Single Forward Type

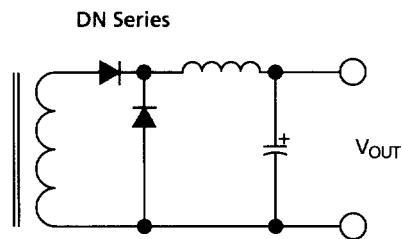

Applications for Push-Pull Converter for Car Amp

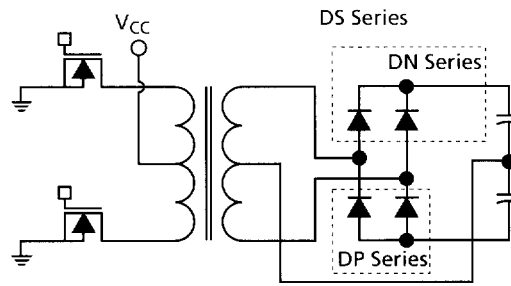

Applications for TV and Monitor

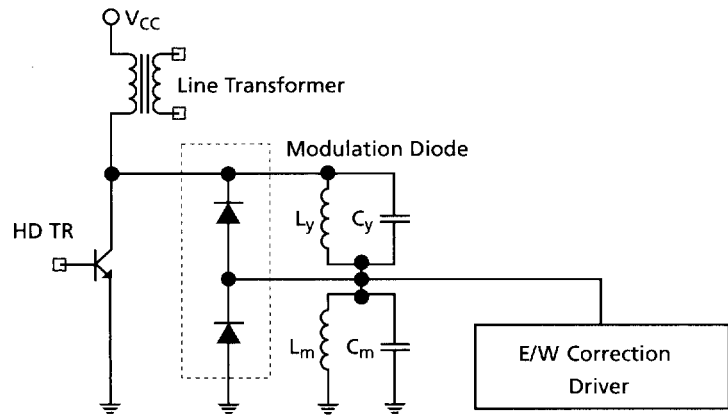

Characteristics

t_{rr} Waveform of Damper Diode

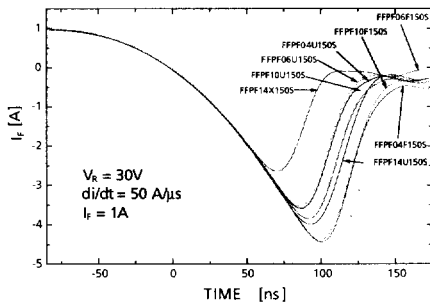

t_{rr} Waveform of Modulation Diode

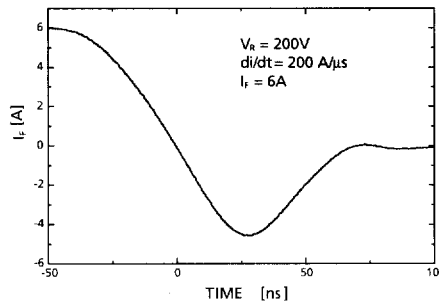

t_{rr} Waveform of FFPF10U60S

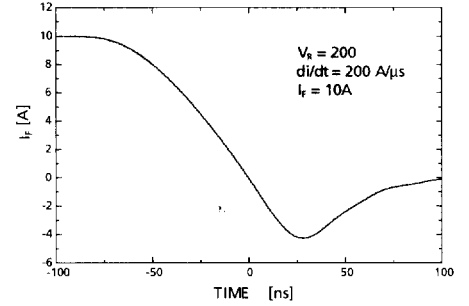

t_{rr} Waveform of FFPF10U40S

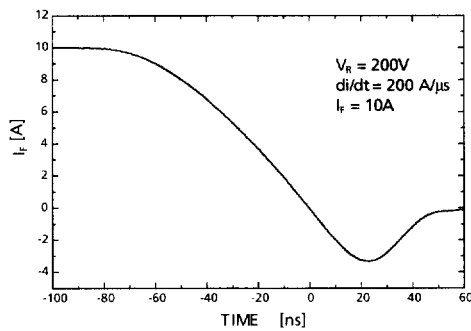

t_{rr} Waveform of FFPF10U20S

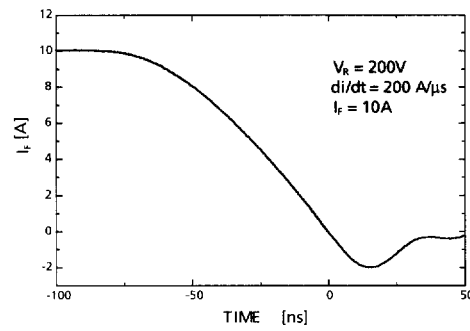

Packaging (all dimensions are in millimeters)

TO-264 (FS PKG Code AR)

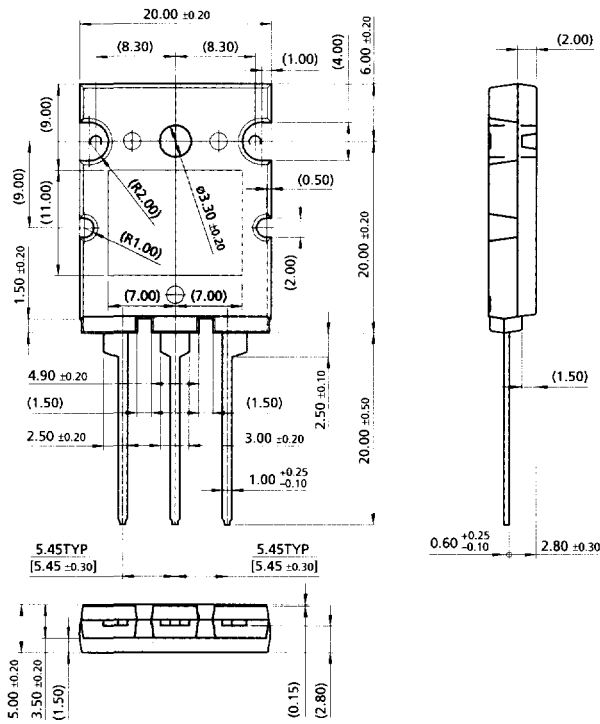

TO-220 (FS PKG Code AE)

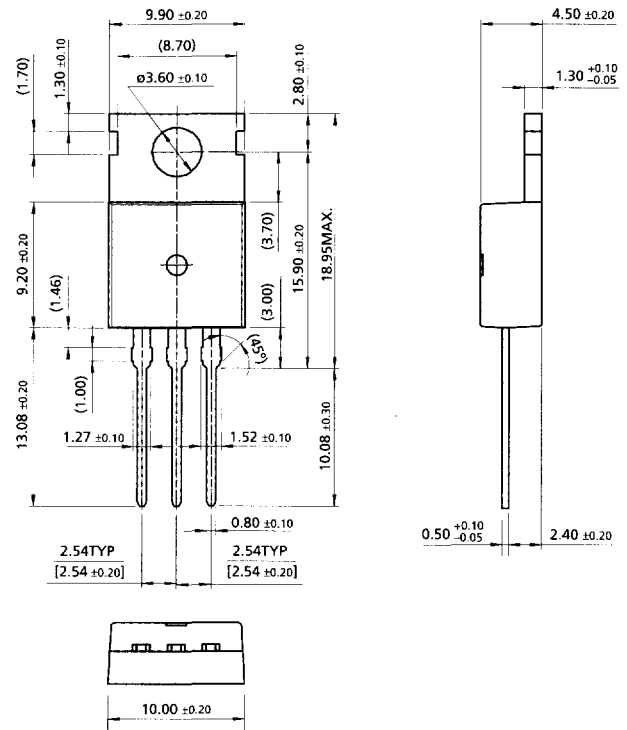

TO-220F (FS PKG Code AQ)

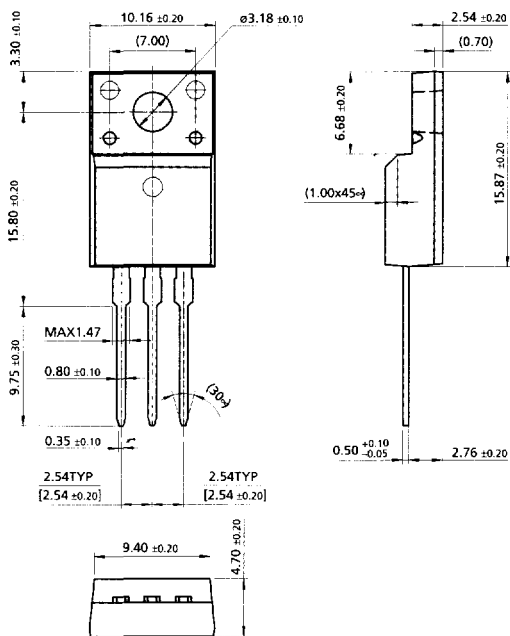

TO-220F-2L (FS PKG Code BL)

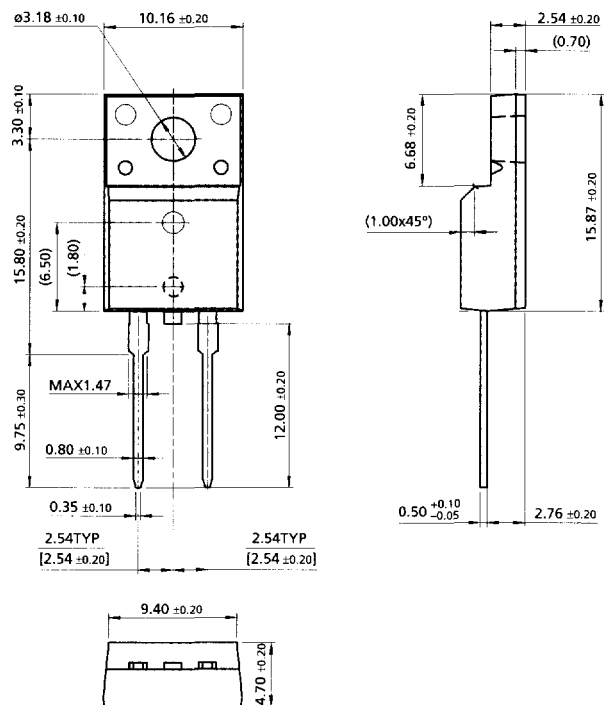

TO-3P (FS PKG Code AF)

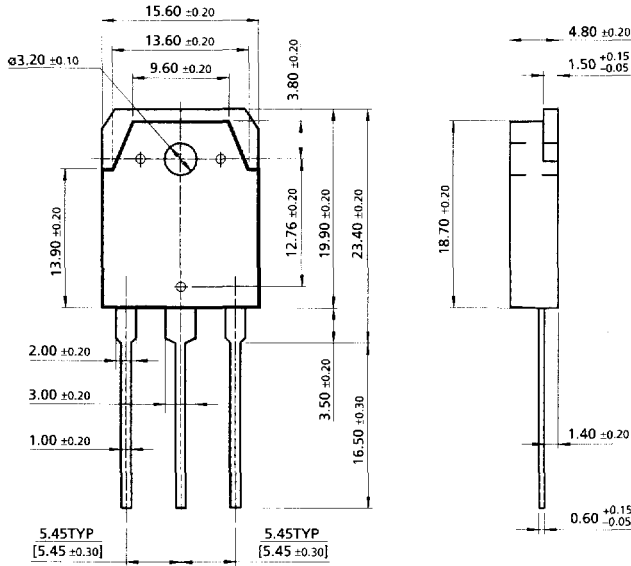

TO-3PF (FS PKG Code AG)

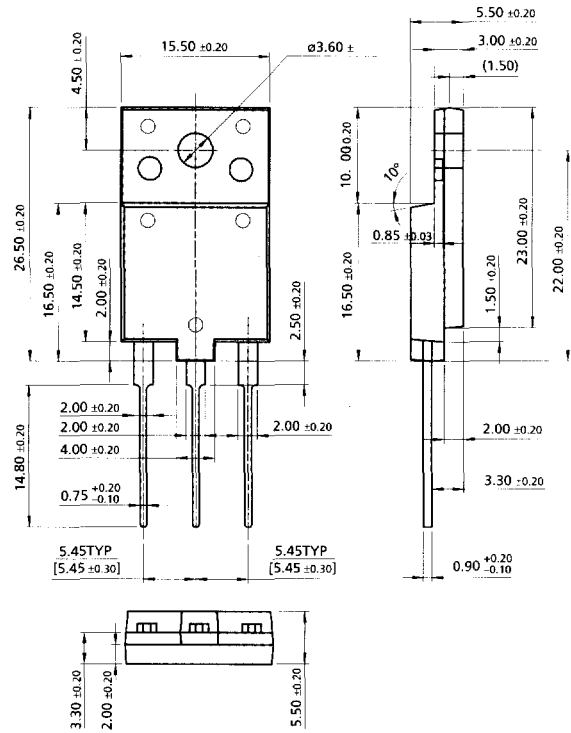

D²-PAK (FS PKG Code AB)

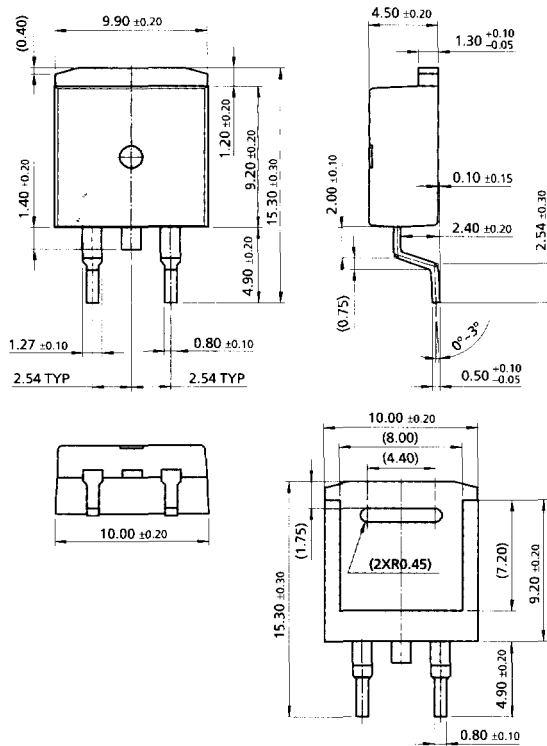

Product Line

Fast Recovery Diodes (FRDs)

FFPF06U20S	FFP06U20DN
FFPF10U20S	FFP10U20DN
FFPF15U20S	FFP15U20DN
FFPF20U20S	FFP04U40DN
FFPF30U20S	FFP06U40DN
FFPF04U40S	FFP05U60DN
FFPF06U40S	FFP10U60DN
FFPF10U40S	FFP20U60DN
FFPF15U40S	FFP30U60DN
FFPF20U40S	FFAF15U20DN
FFPF05U60S	FFAF20U20DN
FFPF10U60S	FFAF10U40DN
FFPF20U60S	FFAF30U60DN
FFPF30U60S	FFAF40U60DN
FFPF40U60S	FFAF60U60DN
FFPF05U120S	FFAF05U120DN
FFPF10U120S	FFAF10U120DN
FFPF15U120S	FFAF15U120DN
FFB05U120S	FFAF20U120DN
FFB10U120S	FFA15U20DN
FFPF06U20DP	FFA20U20DN
FFPF10U20DP	FFA30U20DN
FFPF15U20DP	FFA10U40DN
FFPF04U40DP	FFA15U40DN
FFPF06U40DP	FFA20U40DN
FFPF06U20DN	FFA30U60DN
FFPF10U20DN	FFA40U60DN
FFPF15U20DN	FFA60U60DN
FFPF04U40DN	FFA05U120DN
FFPF06U40DN	FFA10U120DN
FFPF05U60DN	FFA15U120DN
FFPF10U60DN	FFA20U120DN
FFPF20U60DN	FFL60U60DN
FFPF30U60DN	FFL20U120DN
	FFL25U120DN

Schottky Barrier Diodes (SBDs)

FYPF1004DN*	FYAF3004DN*
FYPF1504DN*	FYPF2006DN
FYPF2004DN*	FYPF1010DN

Damper Diodes and Damper & Modulation Diodes

FFPF04F150S	FFPF10U150S
FFPF04U150S	FFPF14U150S
FFPF06F150S	FFPF14X150S
FFPF06U150S	FFPF05U170S*
FFPF10F150S	FFAF60A150DS

*In development

Ordering Codes

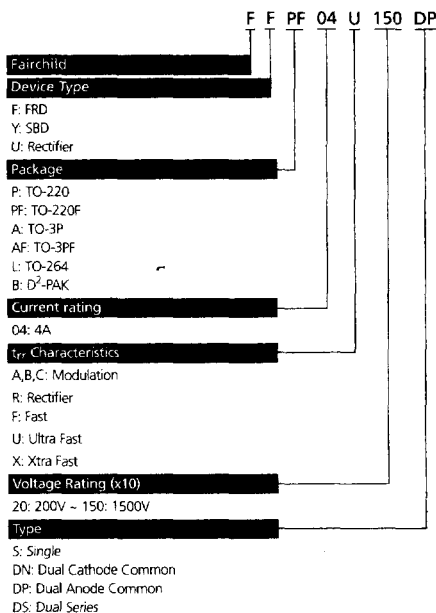

For complete product information and design support, contact the Fairchild sales office in your area.

Americas

Customer Response Center
Fairchild Semiconductor
222 West Las Colinas Boulevard
Suite 380
Irving, TX 75039
Tel: 888-522-5372
Fax: 972-910-8036

China

Fairchild Semiconductor
Hong Kong Ltd.
Shenzhen Representative Office
Room 3107, Shun Hing Square
Di Wang Commercial Centre
5002 Shen Nan Road East
Shenzhen, P.R.C. 518008
Tel: 86-755-246-2088
Fax: 86-755-246-2092

Fairchild Semiconductor
Hong Kong Ltd.
Shanghai Representative Office
Room 1110, Shanghai International
Trade Centre
No. 2200 Yan An (W) Road
Shanghai, P.R.C. 200335
Tel: 86-21-6208-4118
Fax: 86-21-6219-7799

Finland

Fairchild Semiconductor
Itakatu 3 D 213
FIN-00930 Helsinki
Finland
Tel: 358-9-341-1266
Fax: 358-9-341-1292

France

Fairchild Semiconductor
Centre d'Affaires "Le Parc de Massy"
Z.I. De la Bonde
1 bis, Rue Marcel Paul - Bat.B
F-91742 Massy Cedex
France
Tel: 33-1-6930-3696
Fax: 33-1-6930-3693

Germany

Fairchild Semiconductor GmbH
Oskar-von-Miller-Strasse 4e
D-82256 Fürstentfeldbruck
Germany
Tel: 49-8141-61020
Fax: 49-8141-6102-100

Hong Kong

Fairchild Semiconductor
Hong Kong Ltd.
8/F, Room 808
68 Mody Road, Empire Centre
Tsimshatsui East, Kowloon
Hong Kong
Tel: 852-2722-8338
Fax: 852-2722-8383

Italy

Fairchild Semiconductor Srl
Via Carducci, 125
20099 Sesto San Giovanni (MI)
Italy
Tel: 39-02-249111-1
Fax: 39-02-26263424

Japan

Fairchild Semiconductor Japan Ltd.
Natsume Building 4F
2-18-6, Yushima, Bunkyo-ku
Tokyo, 113-0034 Japan
Tel: 81-3-3818-8840
Fax: 81-3-3818-8841

Fairchild Semiconductor Japan Ltd.
Osaka Office
Shin-Osaka Meiko Building 8F
4-3-12, Miyahara, Yodogawa-ku
Osaka, 532-0003 Japan
Tel: 81-6-6398-3670
Fax: 81-6-6398-3680

Korea

Fairchild Korea Semiconductor, Ltd.
82-3, Dodang-Dong,
Wonmi-Ku, Puchon,
Kyunggi-Do, Korea, 420-711
Tel: 82-32-680-1926
Fax: 82-32-680-1949

Fairchild Korea Semiconductor, Ltd.
Suwon Office
6th Floor Song-i Building,
976-12, Youngtong-Dong,
Paldal-Ku, Suwon,
Kyunggi-Do, Korea, 442-470
Tel: 82-331-205-0291/8
Fax: 82-331-205-3352

Fairchild Korea Semiconductor, Ltd.

Kumi Office
5th Floor Shinlim Building
447-2, Songjung-Dong,
Kumi, Kyongsangbuk-Do,
Korea, 730-090
Tel: 82-546-457-4111
Fax: 82-546-457-4121

Mexico

Fairchild Semiconductor
Av. Vallarta #6503 Flr. 14
Col. Cd Granjas
Zapopan Jalisco 45010
Mexico
Tel: 52-3-1100017
Fax: 52-3-1101878

Singapore

Fairchild Semiconductor
Asia Pacific Pte. Ltd.
350 Orchard Road
#20-01/03 Shaw House
Singapore 238868
Tel: 65-836-0936
Fax: 65-838-0321/3

Sweden

Fairchild Semiconductor
Industrivagen 7
SE-171 48 Solna
Sweden
Tel: 46-8-6515530
Fax: 46-8-6515505

Taiwan

Fairchild Semiconductor
Hong Kong Ltd. Taiwan Branch
16/F, No.167
Tun Hwa North Road
Taipei, Taiwan
Tel: 886-2-2712-0500
Fax: 886-2-2716-9285

UK

Fairchild Semiconductor Ltd.
10 Interface Business Park
Wootton Bassett
Swindon SN4 8SY
United Kingdom
Tel: 44-1793-856856
Fax: 44-1793-856857



Visit our web site at
www.fairchildsemi.com



The following are registered and unregistered trademarks Fairchild Semiconductor International owns or is authorized to use and is not intended to be an exhaustive list of all such trademarks: ACEx™, CoolFET™, CROSSVOLT™, E²C MOS™, FACT™, FACT Quiet Series™, FAST®, FAST™, GTO™, HiSeC™, ISOPLANAR™, MICROWIRE™, POP™, PowerTrench®, QFET™, QS™, Quiet Series™, SuperSOT™-3, SuperSOT™-6, SuperSOT™-8, SyncFET™, TinyLogic™, UHC™, VCX™

© 2000 Fairchild Semiconductor International
All Rights Reserved

Lit No. 350001-002