

## Silicon NPN Power Transistors

## BDV65/65A/65B/65C

## DESCRIPTION

- With TO-3PN package
- Complement to type BDV64/64A/64B/64C
- DARLINGTON
- High DC current gain

## APPLICATIONS

- For use in general purpose amplifier applications.

## PINNING

PIN	DESCRIPTION
1	Base
2	Collector;connected to mounting base
3	Emitter

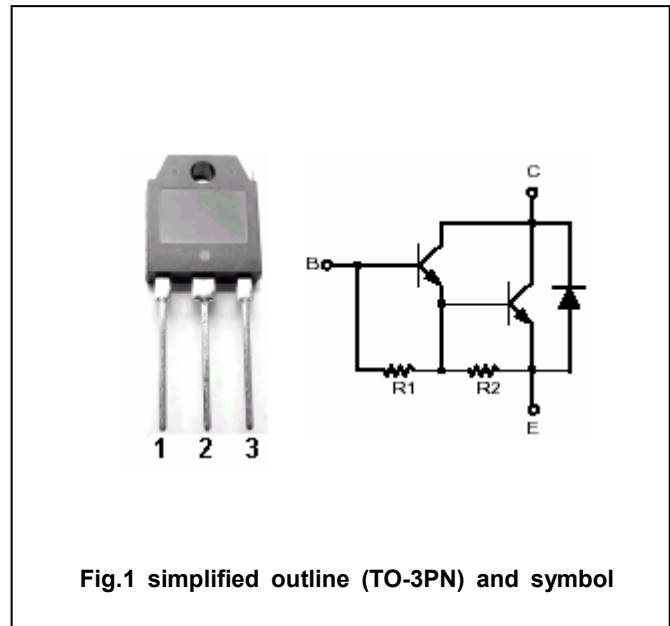

Fig.1 simplified outline (TO-3PN) and symbol

Absolute maximum ratings( $T_c=25^\circ\text{C}$ )

SYMBOL	PARAMETER	CONDITIONS	VALUE	UNIT	
$V_{CBO}$	Collector-base voltage	Open emitter	BDV65	60	V
			BDV65A	80	
			BDV65B	100	
			BDV65C	120	
$V_{CEO}$	Collector-emitter voltage	Open base	BDV65	60	V
			BDV65A	80	
			BDV65B	100	
			BDV65C	120	
$V_{EBO}$	Emitter-base voltage	Open collector	5	V	
$I_C$	Collector current		12	A	
$I_{CM}$	Collector current-peak		15	A	
$I_B$	Base current		0.5	A	
$P_C$	Collector power dissipation	$T_c=25^\circ\text{C}$	125	W	
		$T_a=25^\circ\text{C}$	3.5		
$T_j$	Junction temperature		150	$^\circ\text{C}$	
$T_{stg}$	Storage temperature		-65~150	$^\circ\text{C}$	

## Silicon NPN Power Transistors

## BDV65/65A/65B/65C

## CHARACTERISTICS

T<sub>j</sub>=25 °C unless otherwise specified

www.datasheet4u.com

SYMBOL	PARAMETER	CONDITIONS	MIN	TYP.	MAX	UNIT	
V <sub>(BR)CEO</sub>	Collector-emitter breakdown voltage	BDV65	60			V	
		BDV65A	80				
		BDV65B	100				
		BDV65C	120				
V <sub>CEsat</sub>	Collector-emitter saturation voltage	I <sub>C</sub> =5A, I <sub>B</sub> =20mA			2.0	V	
V <sub>BE</sub>	Base-emitter on voltage	I <sub>C</sub> =5A; V <sub>CE</sub> =4V			2.5	V	
I <sub>CBO</sub>	Collector cut-off current	BDV65	V <sub>CB</sub> =60V, I <sub>E</sub> =0 V <sub>CB</sub> =30V, I <sub>E</sub> =0; T <sub>C</sub> =150 °C			0.4 2.0	mA
		BDV65A	V <sub>CB</sub> =80V, I <sub>E</sub> =0 V <sub>CB</sub> =40V, I <sub>E</sub> =0; T <sub>C</sub> =150 °C			0.4 2.0	
		BDV65B	V <sub>CB</sub> =100V, I <sub>E</sub> =0 V <sub>CB</sub> =50V, I <sub>E</sub> =0; T <sub>C</sub> =150 °C			0.4 2.0	
		BDV65C	V <sub>CB</sub> =120V, I <sub>E</sub> =0 V <sub>CB</sub> =60V, I <sub>E</sub> =0; T <sub>C</sub> =150 °C			0.4 2.0	
I <sub>CEO</sub>	Collector cut-off current	BDV65	V <sub>CE</sub> =30V, I <sub>B</sub> =0			2	mA
		BDV65A	V <sub>CE</sub> =40V, I <sub>B</sub> =0				
		BDV65B	V <sub>CE</sub> =50V, I <sub>B</sub> =0				
		BDV65C	V <sub>CE</sub> =60V, I <sub>B</sub> =0				
I <sub>EBO</sub>	Emitter cut-off current	V <sub>EB</sub> =5V; I <sub>C</sub> =0			5	mA	
h <sub>FE</sub>	DC current gain	I <sub>C</sub> =5A; V <sub>CE</sub> =4V	1000				
V <sub>EC</sub>	Diode forward voltage	I <sub>E</sub> =10A			3.5	V	

## THERMAL CHARACTERISTICS

SYMBOL	PARAMETER	MAX	UNIT
R <sub>th j-c</sub>	Thermal resistance junction to case	1.0	°C/W

Silicon NPN Power Transistors

BDV65/65A/65B/65C

PACKAGE OUTLINE

www.datasheet4u.com

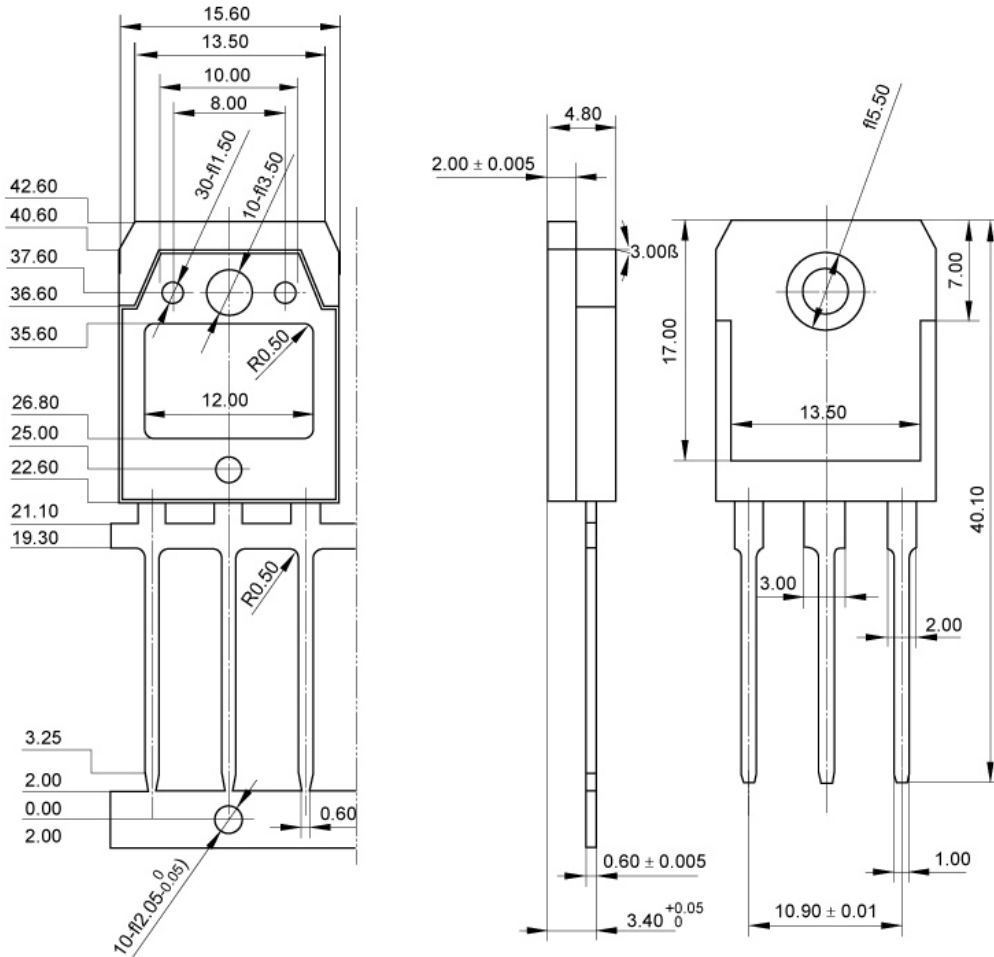

Fig.2 Outline dimensions(unindicated tolerance:±0.1mm)