

Timing Circuit

IN556

The IN556N/D monolithic timing circuit is a highly stable controller capable of producing accurate time delays, or oscillation.

- Timing From Microseconds Through Hours
- Operates in Both Astable and Monostable Modes
- High Current Output Can Source or Sink 200 mA

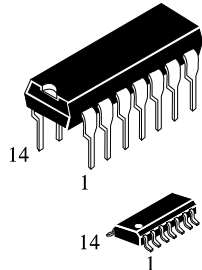

N SUFFIX PLASTIC
D SUFFIX SOIC

ORDERING INFORMATION
IN556N Plastic
IN556D SOIC
 $T_A = -10^\circ \text{ to } 70^\circ \text{ C}$ for all packages

PIN ASSIGNMENT

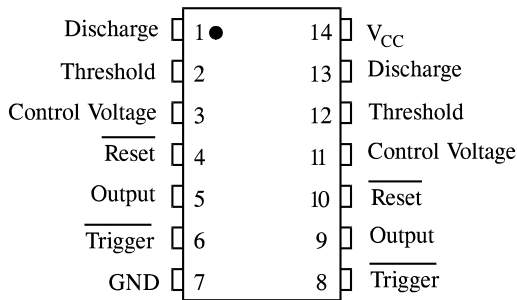

LOGIC DIAGRAM

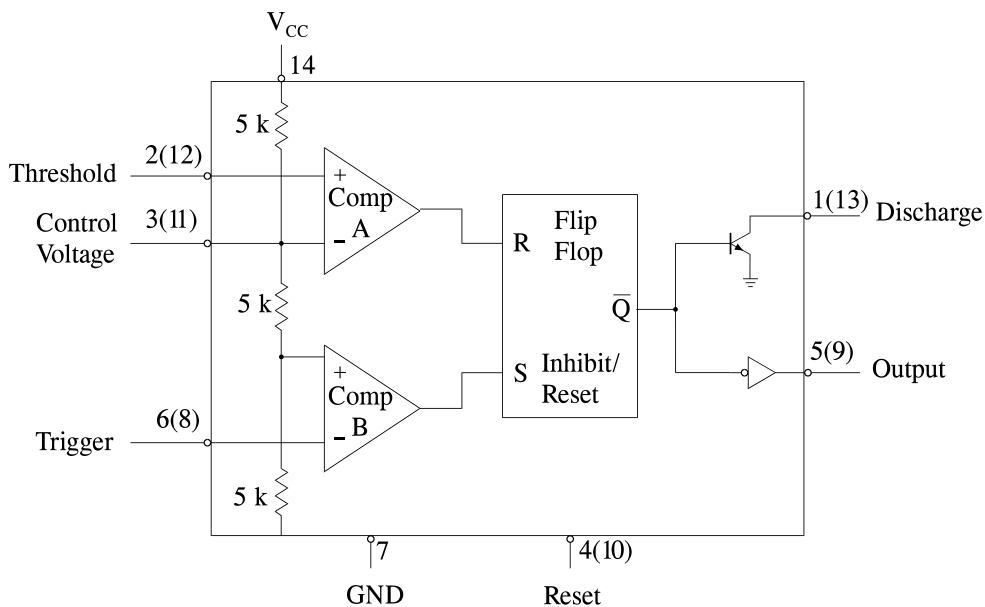

MAXIMUM RATINGS*

Symbol	Parameter	Value	Unit
V _{CC}	Supply Voltage	18	V
T _{stg}	Storage Temperature	-60 to +85	°C

* Stresses beyond those listed under “absolute maximum ratings” may cause permanent damage to the device. These are stress ratings only and functional operation of the device at these or any other conditions beyond those indicated under “recommended operating conditions” is not implied. Exposure to absolute-maximum-rated conditions for extended periods may affect device reliability.

RECOMMENDED OPERATING CONDITIONS

Symbol	Parameter	Min	Max	Unit
V _{CC}	Supply Voltage	4.5	16	V
T _A	Operating Temperature, All Package Types	-10	+70	°C

ELECTRICAL CHARACTERISTICS(T_A =+25°C)

Symbol	Parameter	Test Conditions	Guaranteed Limits		Unit
			Min	Max	
I _{CC}	Supply Current	V _{CC} =5.0 V, R _L =∞ V _{CC} =15 V, R _L =∞		12 30	mA
	Timing Error	R=1.0 kΩ to 100 kΩ Initial Accuracy C = 0.1 μF V _{CC} =5.0 V and V _{CC} =15 V		4	%
V _{th}	Threshold Voltage	V _{CC} =5.0 V V _{CC} =15 V	2.6 9	4.0 11	V
V _T	Trigger Voltage	V _{CC} =5.0 V V _{CC} =15 V	1.1 4.5	2.2 5.6	V
I _T	Trigger Current	V _{06,08} =0 V, V _{CC} =15 V		-2	μA
V _R	Reset Voltage	V _{CC} =15 V	0.4	1.0	V
I _R	Reset Current	V _{04,10} =0 V, V _{CC} =15 V		-0.6	mA
I _{th}	Threshold Current (Note 1)	V _{02,12} =10 V, V _{CC} =15 V		0.25	μA
I _{dis}	Discharge Leakage Current	V _{CC} =15 V, V _{01,13} =15 V		100	nA
V _{REF}	Control Voltage Level	V _{CC} =15 V V _{CC} =5.0 V	9.0 2.6	11 4.0	V
V _{OL}	Output Voltage Low	(V _{CC} =15 V) I _{sink} =10 mA, I _{sink} =50 mA, I _{sink} =100 mA, V _{CC} =5.0 V, I _{sink} =5.0 mA		0.25 0.75 2.3 0.35	V
V _{OH}	Output Voltage High	I _{source} =200 mA, V _{CC} =15 V I _{source} =100 mA, V _{CC} =15 V I _{source} =100 mA, V _{CC} =5.0 V	12 12.75 2.75		V
t _{OLH}	Rise Time of Output	V _{CC} =15 V		300	ns
t _{OHL}	Fall Time of Output	V _{CC} =15 V		300	ns

Note 1. This will determine the maximum value of R_A + R_B for 15 V operation. The maximum total R=20 MΩ.

**N SUFFIX PLASTIC DIP
(MS - 001AA)**

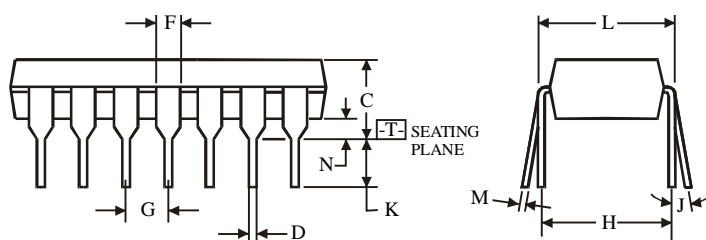
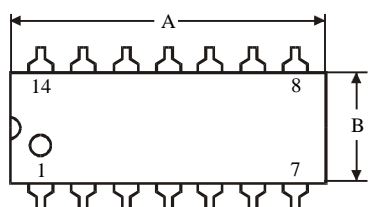
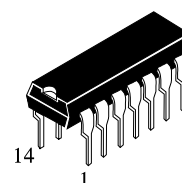

$\oplus 0.25 (0.010) \text{ (M) T}$

NOTES:

- Dimensions "A", "B" do not include mold flash or protrusions.
Maximum mold flash or protrusions 0.25 mm (0.010) per side.

Symbol	Dimension, mm	
	MIN	MAX
A	18.67	19.69
B	6.1	7.11
C		5.33
D	0.36	0.56
F	1.14	1.78
G	2.54	
H	7.62	
J	0°	10°
K	2.92	3.81
L	7.62	8.26
M	0.2	0.36
N	0.38	

**D SUFFIX SOIC
(MS - 012AB)**

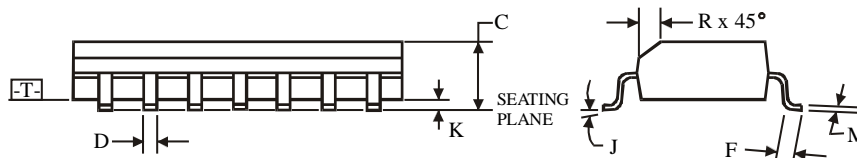
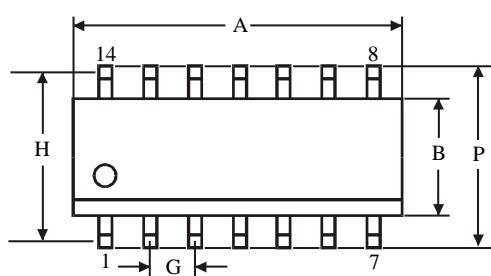
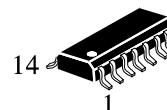

$\oplus 0.25 (0.010) \text{ (M) T C (M)}$

NOTES:

- Dimensions A and B do not include mold flash or protrusion.
- Maximum mold flash or protrusion 0.15 mm (0.006) per side for A; for B - 0.25 mm (0.010) per side.

Symbol	Dimension, mm	
	MIN	MAX
A	8.55	8.75
B	3.8	4
C	1.35	1.75
D	0.33	0.51
F	0.4	1.27
G	1.27	
H	5.27	
J	0°	8°
K	0.1	0.25
M	0.19	0.25
P	5.8	6.2
R	0.25	0.5