

DO NOT SCALE FROM THIS PRINT

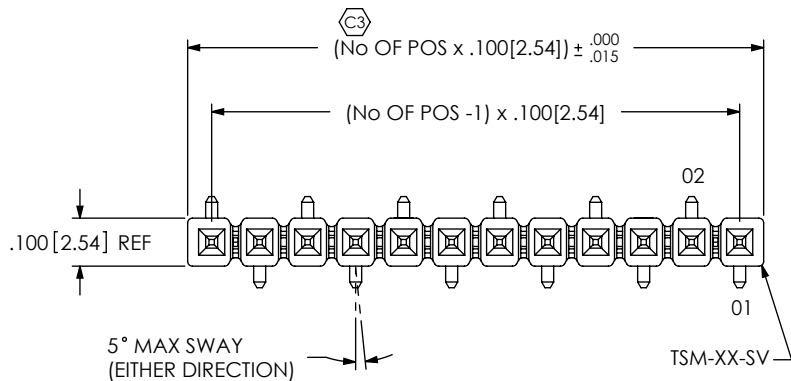

TSM-1XX-XX-XXX-SV-XX-XXX-XX

No OF POSITIONS
-02 THRU -50

LEAD STYLE
SEE TABLE 1

PLATING SPECIFICATION

- T: TIN (USE T-1S6-XX-T-2)
- S: SELECTIVE (USE T-1S6-XX-S-2)
- G: GOLD (USE T-1S6-XX-G-2)
- L: LIGHT SELECTIVE (USE T-1S6-XX-L-2)
- F: FLASH SELECTIVE (USE T-1S6-XX-F-2)
- H: HEAVY GOLD (USE T-1S6-XX-H-2)
- P: GOLD FLASHED PALLADIUM NICKEL (USE T-1S6-XX-P-2)
- TL: TIN / LEAD (USE T-1S6-XX-TL-2) [LEAD STYLE -01 & -02 ONLY]
- STL: SELECTIVE TIN / LEAD (USE T-1S6-XX-STL-2) [LEAD STYLE -01 & -02 ONLY]
- TM: MATTE TIN
- SM: SELECTIVE HEAVY GOLD, MATTE TIN ON TAIL
- LM: SELECTIVE LIGHT GOLD, MATTE TIN ON TAIL
- FM: FLASH SELECTIVE GOLD, MATTE TIN ON TAIL

OPTION #3
-P: PICK & PLACE PAD (SEE FIG. 3) [USE PPP-07] (4 POS MINIMUM OR -02 & -03 POS WITH -TR) (SEE NOTE 7)
-TR: TAPE & REEL (SEE NOTE 7) (-02 THRU -22 POS)

OPTION #2
POLARIZED POSITION: SPECIFY PIN OMITTED

OPTION #1
-LC: LOCKING CLIP (SEE FIG. 1) (SEE NOTE 8) [USE LC-08-TM-02] (-02 THRU -36 POS: 2 PER STRIP -02 POS: 1 PER STRIP)
-A: ALIGNMENT PIN (SEE FIG. 2)

ROW SPECIFICATION
-SV: SINGLE VERTICAL (USE TSM-XX-SV-XX)

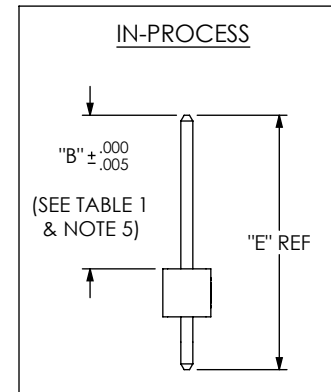
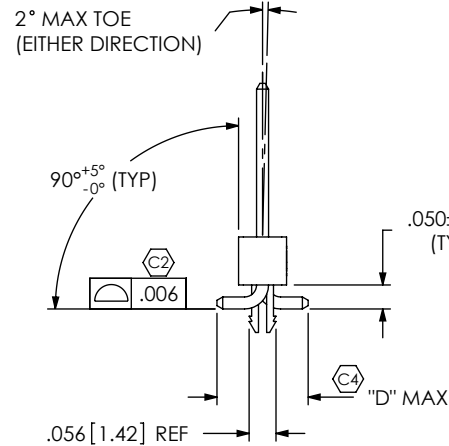
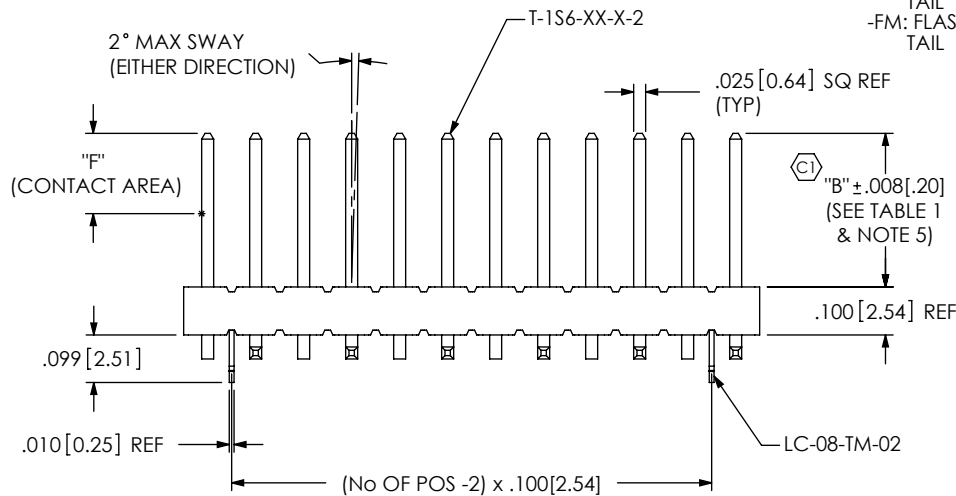

NOTES:

1. Ⓢ REPRESENTS A CRITICAL DIMENSION.
2. COPLANARITY TO BE WITHIN .006[.15].
3. BURR ALLOWANCE: .0015[.038] MAX.
4. MAXIMUM CUT FLASH: .015[.38] MAXIMUM ON TOP & SIDES OF BODY AND .030[.76] MAXIMUM ON SURFACE MOUNT SIDE OF BODY.
5. POST HEIGHT VARIATION BETWEEN ANY TWO PINS: .005[.13] MAXIMUM.
6. MAXIMUM ALLOWABLE BOW: .002[.05] INCH/INCH AFTER ASSEMBLY.
7. LEADS MAY NOT BE VISIBLE FOR CUSTOMER VISUAL INSPECTOIN WITH -P OPTION ON SMALLER POSITIONS PARTS.
8. DUE TO THE HIGH AMOUNT OF INSERTION FORCE NEEDED, THE -LC OPTION IS NOT COMPATIBLE WITH AUTO PLACEMENT. SAMTEC RECOMMENDS MANUAL PLACEMENT FOR ALL ASSEMBLIES WITH THE -LC OPTION.

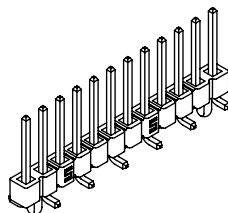

FIG. 1

TSM-112-02-XXX-SV-LC SHOWN

TABLE 1						
STYLE	"B"	"C"	"D" MAX	"E"	"F"	TERMINAL
-01	.230[5.84]	.280[7.11]	.208[5.28]	.445[11.30]	.165 [4.19]	T-1S6-16-X-2
-02	.320[8.13]	.370[9.40]	.193[4.90]	.530[13.46]	.165 [4.19]	T-1S6-08-X-2
-03	.420[10.67]	.470[11.94]	.193[4.90]	.630[16.00]	.165 [4.19]	T-1S6-15-X-2
-04	.120[3.05]	.270[6.86]	.208[5.28]	.335[8.51]	.050 [1.27]	T-1S6-21-X-2
-05	.075[1.91]	.270[6.86]	.223[5.66]	.300[7.62]	.050 [1.27]	T-1S6-18-X-2

UNLESS OTHERWISE SPECIFIED, DIMENSIONS ARE IN INCHES. TOLERANCES ARE:
DECIMALS ANGLES
.XX: ±.01 [.3] 2°
.XXX: ±.005 [.13]
.XXXX: ±.0020 [.051]

PROPRIETARY NOTE

THIS DOCUMENT CONTAINS INFORMATION CONFIDENTIAL AND PROPRIETARY TO SAMTEC, INC. AND SHALL NOT BE REPRODUCED OR TRANSFERRED TO OTHER DOCUMENTS OR DISCLOSED TO OTHERS OR USED FOR ANY PURPOSE OTHER THAN THAT WHICH IT WAS OBTAINED WITHOUT THE EXPRESSED WRITTEN CONSENT OF SAMTEC, INC.

MATERIAL: DO NOT SCALE DRAWING
INSULATOR: LCP, COLOR: BLACK
TERMINAL: PHOS BRONZE

SHEET SCALE: 2.5:1



520 PARK EAST BLVD, NEW ALBANY, IN 47150
PHONE: 812-944-6733 FAX: 812-948-5047
e-Mail: info@SAMTEC.com code 55322

DESCRIPTION: SINGLE ROW .100 SMT ASSEMBLY

DWG. NO. TSM-1XX-XX-XXX-SV-XX-XXX-XX

BY: DEAN P 8/21/2002 SHEET 1 OF 2

FIG. 3
 -P: PICK & PLACE PAD OPTION
 4 POSITION MINIMUM
 [PLACE PAD ON CENTERLINE AS SHOWN]

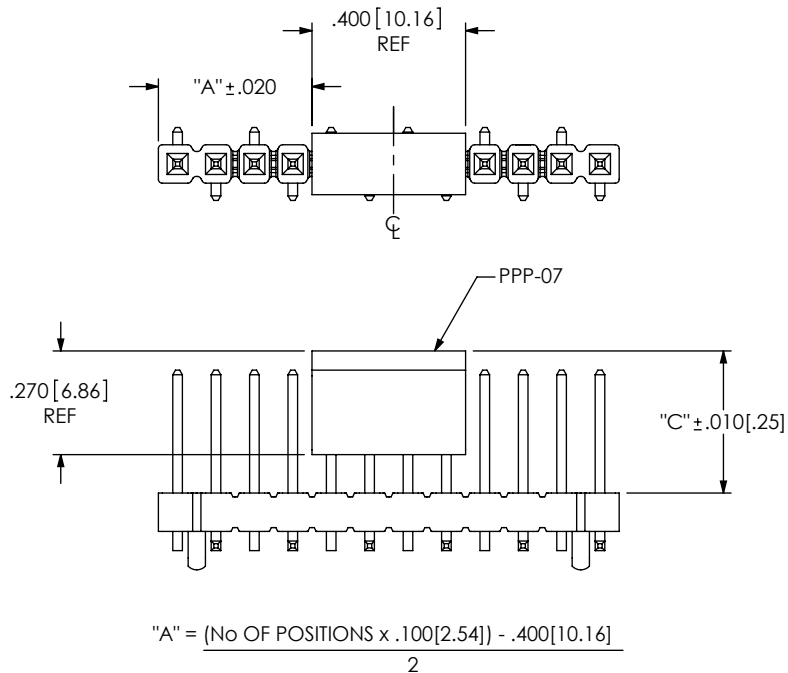

FIG. 2
 -A: ALIGNMENT PIN OPTION
 TSM-112-02-X-SV-A SHOWN
 [DIFFERENT AS SHOWN, OTHERWISE SAME AS FIG. 1]

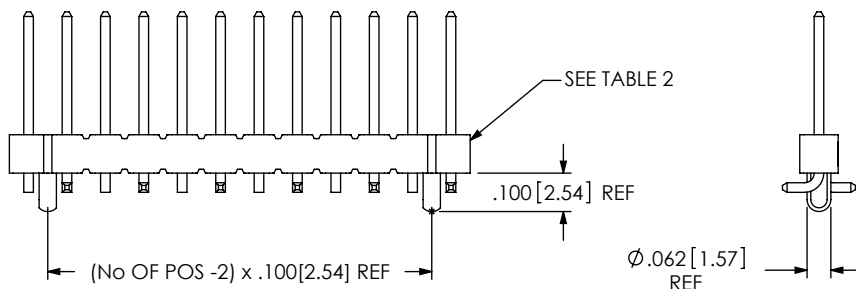

TABLE 2: ALIGNMENT PIN BODY	
POSITION	USE BODY
-02 THRU -03	* TSM-XX-SV-A
-04 THRU -50	TSM-XX-SV-XX

* NOTE: POSITIONS -02 THRU -03 MUST BE MOLD TO POSITION

PACKAGING TABLE			
STYLE	OPTION	TUBE	PLUG
-01	----	PT-1-24-02-29 (SEE NOTE 3)	TP-24
-02, -04, -05	----	PT-1-24-02-29 (SEE NOTE 3)	TP-24
-01, -02, -04, -05	-LC, -A	PT-1-24-02-29 (SEE NOTE 3)	TP-24
-01, -04, -05	-P	PT-1-24-05-29	TP-03
-01, -04, -05	-LC-P, -A-P	PT-1-24-05-29	TP-03
-02	-P	PT-1-24-13-29	TP-03
-02	-LC-P, -A-P	PT-1-24-13-29	TP-03
-03	----	PT-1-24-10-29 (SEE NOTE 3)	TP-24
-03	-LC, -A	PT-1-24-10-29 (SEE NOTE 3)	TP-24
-03	-P	PT-1-24-14-29	TP-09
-03	-LC-P, -A-P	PT-1-24-14-29	TP-09

NOTES:
 1. LOAD PARTS POSITION 1 FIRST IN SAME DIRECTION AS ARROW.
 2. NOTE DELETED
 3. PACKAGE POSITIONS -04 THRU -36.

FIG. 4
 TUBE PACKAGING

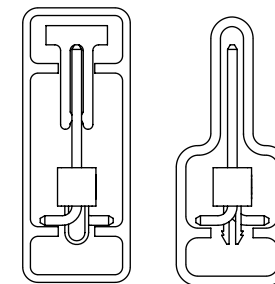
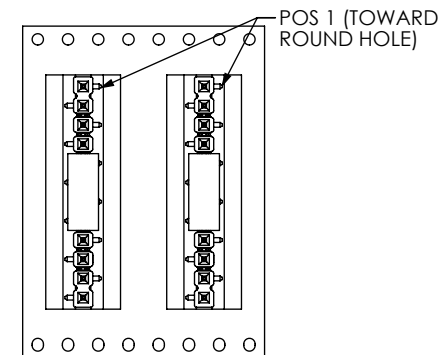
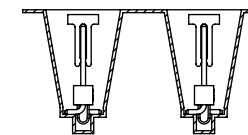

FIG. 5
 -TR: TAPE & REEL PACKAGNG OPTION



USER DIRECTION OF UN-REELING
 POCKET NOT DETAILED



F:\DWG\MISC\MKTG\TSM-1XX-XX-XXX-SV-XX-XXX-XX-MKT.SLDRW

PROPRIETARY NOTE

THIS DOCUMENT CONTAINS INFORMATION CONFIDENTIAL AND PROPRIETARY TO SAMTEC, INC. AND SHALL NOT BE REPRODUCED OR TRANSFERRED TO OTHER DOCUMENTS OR DISCLOSED TO OTHERS OR USED FOR ANY PURPOSE OTHER THAN THAT WHICH IT WAS OBTAINED WITHOUT THE EXPRESSED WRITTEN CONSENT OF SAMTEC, INC.

DO NOT SCALE DRAWING

SHEET SCALE: 2:1



520 PARK EAST BLVD, NEW ALBANY, IN 47150
 PHONE: 812-944-6733 FAX: 812-948-5047
 e-Mail: info@SAMTEC.com code 55322

DESCRIPTION: SINGLE ROW .100 SMT ASSEMBLY

DWG. NO. TSM-1XX-XX-XXX-SV-XX-XXX-XX

BY: DEAN P 8/21/2002 SHEET 2 OF 2