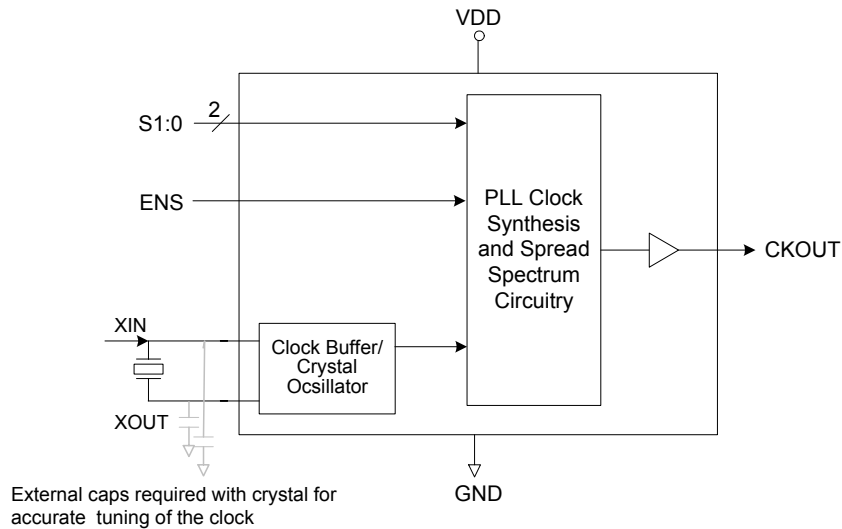

**SPREAD SPECTRUM CLOCK GENERATOR**
**ICS7151**
**Description**

The ICS7151-10, -20, -40, and -50 are clock generators for EMI (Electro Magnetic Interference) reduction (see below for frequency ranges and multiplier ratios). Spectral peaks can be attenuated by slightly modulating the oscillation frequency. Both down and center spread profiles are selectable. Down spread maintains an average frequency less than an unspread clock, and will not exceed the maximum frequency of an unspread clock.

**Features**

- Operating voltage of 3.3 V  $\pm$ 0.3 V
- Packaged in 8-pin SOIC
- Available in Pb (lead) free package
- Input frequency range of 16.5 to 33.4 MHz
- Output frequency ranges of 8.3 to 16.7 MHz, 16.5 to 33.4 MHz, 33.3 to 66.7 MHz, 66.6 to 133.4 MHz
- Provides a spread spectrum clock output ( $\pm$ 0.5%,  $\pm$ 1.5% center spread; -1.0%, -3.0% down spread)
- Multiplication rates of x1/2, x1, x2, and x4
- Advanced, low-power CMOS process

**Block Diagram**

**Product Lineup**

| Product                   | Input Frequency Range | Multiplier Ratio | Output Frequency Range |
|---------------------------|-----------------------|------------------|------------------------|
| ICS7151M-10, ICS7151MI-10 | 16.5 MHz to 33.4 MHz  | X1               | 16.5 MHz to 33.4 MHz   |
| ICS7151M-20, ICS7151MI-20 | 16.5 MHz to 33.4 MHz  | X2               | 33.3 MHz to 66.7 MHz   |
| ICS7151M-40, ICS7151MI-40 | 16.5 MHz to 33.4 MHz  | X4               | 66.6 MHz to 133.4 MHz  |
| ICS7151M-50, ICS7151MI-50 | 16.5 MHz to 33.4 MHz  | X1/2             | 8.3 MHz to 16.7 MHz    |

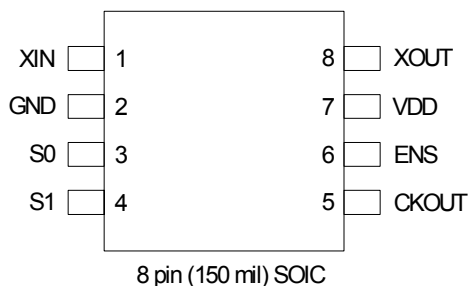
## Pin Assignment



## Spread Direction and Percentage Select Table

| S1<br>Pin 4<br>(note1) | S0<br>Pin 3<br>(note1) | Spread<br>Direction | Spread<br>Percentage (%) |
|------------------------|------------------------|---------------------|--------------------------|
| 0                      | 0                      | Center              | ±1.5                     |
| 0                      | 1                      | Center              | ±0.5                     |
| 1                      | 0                      | Down                | -1.0                     |
| 1                      | 1                      | Down                | -3.0                     |
| ENS<br>(note 2)        |                        | Spread Spectrum     |                          |
| 0                      |                        | OFF                 |                          |
| 1                      |                        | ON                  |                          |

Notes:

1. The modulation rate varies with input frequency.
2. Spread will default to ON when ENS pin is left open.

## Pin Descriptions

| Pin Number | Pin Name | Pin Type | Pin Description   |
|------------|----------|----------|---|
| 1          | XIN      | Input    | Resonator connection pin/clock input pin.                 |
| 2          | GND      | Power    | Connect to ground.  |
| 3          | S0       | Input    | Select pin 0. Modulation rate setting pin.                |
| 4          | S1       | Input    | Select pin 1. Modulation rate setting pin.                |
| 5          | CKOUT    | Output   | Modulated clock output pin.                               |
| 6          | ENS      | Input    | Modulation enable setting pin. Internal pull-up resistor. |
| 7          | VDD      | Power    | Connect to +3.3 V.  |
| 8          | XOUT     | Output   | Resonator connection pin.                                 |

## External Components

The ICS7151 requires a minimum number of external components for proper operation.

### Decoupling Capacitor

A decoupling capacitor of 0.01 $\mu$ F must be connected between GND and VDD on pin 7, as close to this pin as possible. For optimum device performance, the decoupling capacitor should be mounted on the component side of the PCB. Avoid the use of vias in the decoupling circuit.

### Series Termination Resistor

Series termination should be used on the clock output. To series terminate a 50 $\Omega$  trace (a commonly used trace impedance) place a 27 $\Omega$  resistor in series with the clock line, as close to the clock output pin as possible. The nominal impedance of the clock output is 25 $\Omega$ .

## PCB Layout Recommendations

For optimum device performance and lowest output phase noise, the following guidelines should be observed.

- 1) The 0.01 $\mu$ F decoupling capacitor should be mounted on the component side of the board as close to the VDD pin as possible. No vias should be used between the decoupling capacitor and VDD pin. The PCB trace to VDD pin should be kept as short as possible, as should the PCB trace to the ground via.
- 2) To minimize EMI, the 27 $\Omega$  series termination resistor (if needed) should be placed close to the clock output.
- 3) An optimum layout is one with all components on the same side of the board, minimizing vias through other signal layers. Other signal traces should be routed away from the ICS7151. This includes signal traces just underneath the device, or on layers adjacent to the ground plane layer used by the device.

## Crystal Information

The crystal used should be a fundamental mode (do not use third overtone), parallel resonant. Crystal capacitors should be connected from pins X1 to ground and X2 to ground to optimize the initial accuracy. The value of these capacitors is given by the following equation:

$$\text{Crystal caps (pF)} = (C_L - 6) \times 2$$

In the equation,  $C_L$  is the crystal load capacitance. So, for a crystal with a 16 pF load capacitance, two 20 pF  $[(16-6) \times 2]$  capacitors should be used.

## Spread Spectrum Profile

The ICS7151 low EMI clock generator uses a triangular frequency modulation profile for optimal down stream tracking of zero delay buffers and other PLL devices. The frequency modulation amplitude is constant with variations of the input frequency.

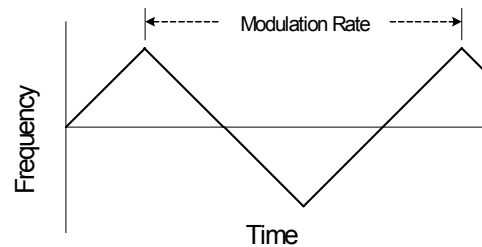

## Absolute Maximum Ratings

Stresses above the ratings listed below can cause permanent damage to the ICS7151. These ratings, which are standard values for ICS commercially rated parts, are stress ratings only. Functional operation of the device at these or any other conditions above those indicated in the operational sections of the specifications is not implied. Exposure to absolute maximum rating conditions for extended periods can affect product reliability. Electrical parameters are guaranteed only over the recommended operating temperature range.

| Item                                       | Rating                                |
|--|---------------------------------------|
| Supply Voltage, VDD                        | 7 V                                   |
| All Inputs and Outputs (referenced to GND) | -0.5 V to VDD+0.5 V                   |
| Ambient Operating Temperature              | -40 to +85° C                         |
| Storage Temperature                        | -55 to +125° C                        |
| Junction Temperature                       | -40 to +125° C                        |
| Soldering Temperature                      | 260° C                                |
| Overshoot ( $V_{IOVER}$ )                  | VDD + 1.0 V ( $t_{OVER} \leq 50$ ns)  |
| Undershoot ( $V_{IUNDER}$ )                | GND - 1.0 V ( $t_{UNDER} \leq 50$ ns) |

### Overshoot/Undershoot

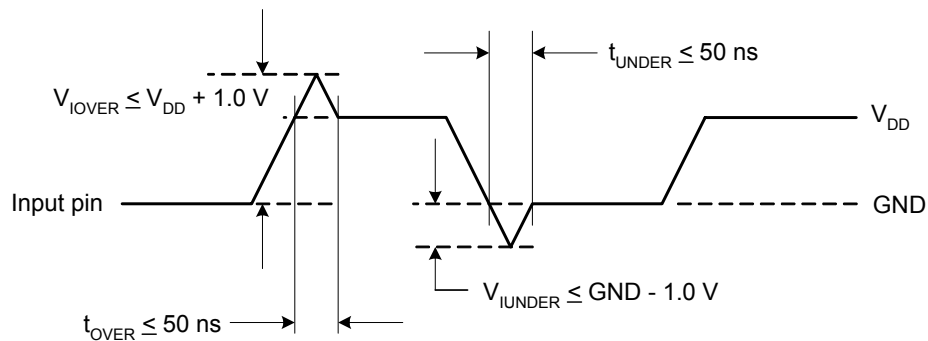

## Recommended Operation Conditions

| Parameter   | Min. | Typ. | Max. | Units |
|---|------|------|------|-------|
| Ambient Operating Temperature                     | -40  |      | +85  | °C    |
| Power Supply Voltage (measured in respect to GND) | +3.0 | 3.3  | 3.6  | V     |

## DC Electrical Characteristics

Unless stated otherwise,  $V_{DD} = 3.3\text{ V} \pm 0.3\text{ V}$ , Ambient Temperature  $-40$  to  $+85^\circ\text{C}$

| Parameter              | Symbol          | Conditions                     | Min.    | Typ. | Max.      | Units |
|------------------------|-----------------|--------------------------------|---------|------|-----------|-------|
| Operating Voltage      | VDD             |                                | 3.0     | 3.3  | 3.6       | V     |
| Supply Current         | IDD             | No load, at 3.3 V              |         | 10   | 20        | mA    |
| Input High Voltage     | V <sub>IH</sub> | XIN, S0, S1, ENS               | VDDx0.8 |      | VDD + 0.3 | V     |
| Input Low Voltage      | V <sub>IL</sub> | XIN, S0, S1, ENS               | 0.0     |      | VDDx0.20  | V     |
| Output High Voltage    | V <sub>OH</sub> | CKOUT, I <sub>OH</sub> = -4 mA | VDD-0.5 |      |           | V     |
| Output Low Voltage     | V <sub>OL</sub> | CKOUT, I <sub>OL</sub> = 4 mA  |         |      | 0.4       | V     |
| Input Capacitance      | C <sub>IN</sub> | XIN, S0, S1, ENS               |         |      | 16        | pF    |
| Load Capacitance       | C <sub>L</sub>  | CKOUT, 8.3 to 66.7 MHz         |         |      | 15        | pF    |
|                        |                 | CKOUT, 66.7 to 100 MHz         |         |      | 10        | pF    |
|                        |                 | CKOUT, 100 to 133.4 MHz        |         |      | 7         | pF    |
| Input Pull-up Resistor | R <sub>PU</sub> | ENS                            | 100     | 240  | 400       | kΩ    |

## AC Electrical Characteristics

Unless stated otherwise,  $V_{DD} = 3.3\text{ V} \pm 0.3\text{ V}$ , Ambient Temperature  $-40$  to  $+85^\circ\text{C}$

| Parameter               | Symbol           | Conditions                               | Min. | Typ. | Max.  | Units |
|-------------------------|------------------|--|------|------|-------|-------|
| Input Crystal Frequency |                  |  | 16.5 |      | 33.4  | MHz   |
| Input Clock Frequency   | f <sub>IN</sub>  |  | 16.5 |      | 33.4  | MHz   |
| Output Frequency        | f <sub>OUT</sub> | CKOUT, Multiply by 1 (ICS7151-10)        | 16.5 |      | 33.4  | MHz   |
|                         |                  | CKOUT, Multiply by 2 (ICS7151-20)        | 33.3 |      | 66.7  | MHz   |
|                         |                  | CKOUT, Multiply by 4 (ICS7151-40)        | 66.6 |      | 133.4 | MHz   |
|                         |                  | CKOUT, 2-frequency division (ICS7151-50) | 8.3  |      | 16.7  | MHz   |
| Input Clock Duty Cycle  |                  | XIN, 16.5 to 33.4 MHz                    | 40   | 50   | 60    | %     |
| Output Clock Duty Cycle | t <sub>DCC</sub> | CKOUT, 1.5 V                             | 40   |      | 60    | %     |
| Output Slew Rate        |                  | CKOUT, 0.4 to 2.4 V, CL = 15 pF          | 0.5  |      | 3.0   | V/ns  |

| Parameter             | Symbol    | Conditions                                       | Min. | Typ. | Max. | Units |
|-----------------------|-----------|--|------|------|------|-------|
| Cycle to Cycle Jitter | $t_{JC}$  | No load, spread off (ICS7151-10, -20)            |      |      | 100  | ps    |
|                       |           | No load, spread off (ICS7151-40)                 |      |      | 150  | ps    |
|                       |           | No load, spread off (ICS7151-50)                 |      |      | 200  | ps    |
| Power-up Time         |           | PLL lock-time from power-up to 1% of final value |      | 2    | 5    | ms    |
| Modulation Frequency  | $f_{MOD}$ | CKOUT  |      | 33   |      | kHz   |

### Input Frequency ( $f_{IN} = 1/t_{IN}$ )

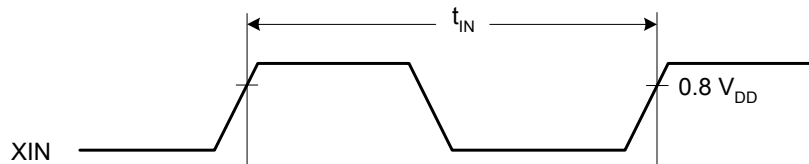

### Output Slew Rate

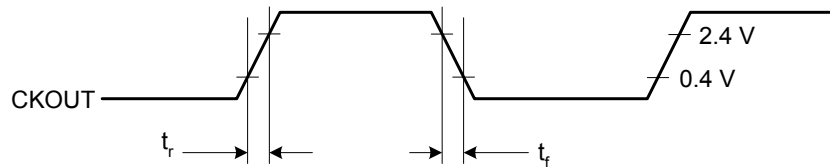

$$SR = (2.4 - 0.4) / t_r, SR = (2.4 - 0.4) / t_r$$

## Thermal Characteristics 8 SOIC

| Parameter                              | Symbol        | Conditions     | Min. | Typ. | Max. | Units         |
|--|---------------|----------------|------|------|------|---------------|
| Thermal Resistance Junction to Ambient | $\theta_{JA}$ | Still air      |      | 150  |      | $^{\circ}C/W$ |
|  | $\theta_{JA}$ | 1 m/s air flow |      | 140  |      | $^{\circ}C/W$ |
|  | $\theta_{JA}$ | 3 m/s air flow |      | 120  |      | $^{\circ}C/W$ |
| Thermal Resistance Junction to Case    | $\theta_{JC}$ |                |      | 40   |      | $^{\circ}C/W$ |

## Package Outline and Package Dimensions (8-pin SOIC, 150 Mil. Body)

Package dimensions are kept current with JEDEC Publication No. 95

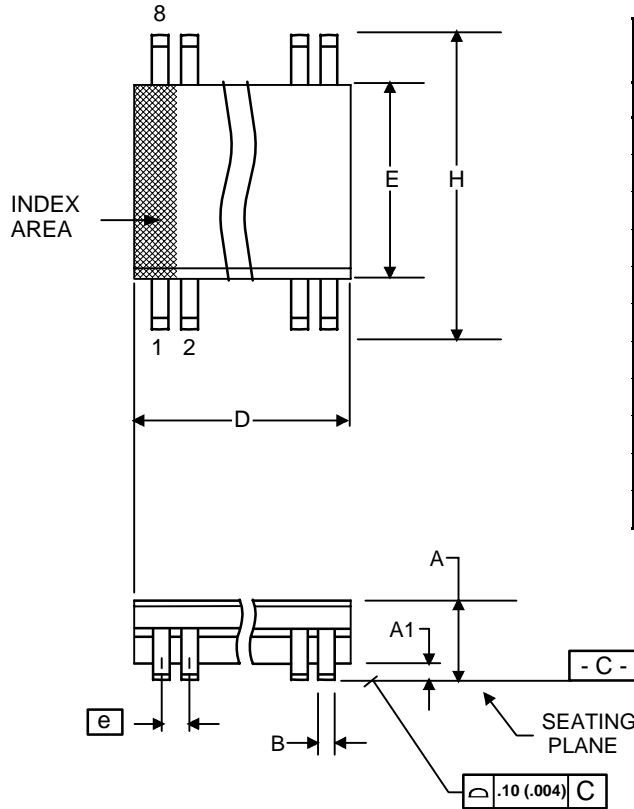

| Symbol   | Millimeters |      | Inches      |       |
|----------|-------------|------|-------------|-------|
|          | Min         | Max  | Min         | Max   |
| A        | 1.35        | 1.75 | .0532       | .0688 |
| A1       | 0.10        | 0.25 | .0040       | .0098 |
| B        | 0.33        | 0.51 | .013        | .020  |
| C        | 0.19        | 0.25 | .0075       | .0098 |
| D        | 4.80        | 5.00 | .1890       | .1968 |
| E        | 3.80        | 4.00 | .1497       | .1574 |
| e        | 1.27 BASIC  |      | 0.050 BASIC |       |
| H        | 5.80        | 6.20 | .2284       | .2440 |
| h        | 0.25        | 0.50 | .010        | .020  |
| L        | 0.40        | 1.27 | .016        | .050  |
| $\alpha$ | 0°          | 8°   | 0°          | 8°    |

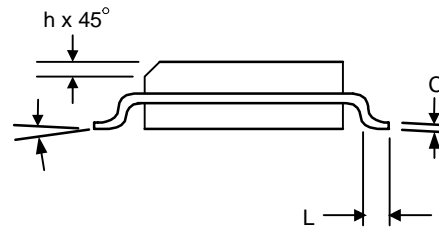

## Ordering Information

| Part / Order Number | Marking  | Shipping Packaging | Package    | Temperature   |
|---------------------|----------|--------------------|------------|---------------|
| 7151M-10            | 7151M-10 | Tubes              | 8-pin SOIC | 0 to +70° C   |
| 7151M-10T           | 7151M-10 | Tape and Reel      | 8-pin SOIC | 0 to +70° C   |
| 7151M-10LF          | 51M-10LF | Tubes              | 8-pin SOIC | 0 to +70° C   |
| 7151M-10LFT         | 51M-10LF | Tape and Reel      | 8-pin SOIC | 0 to +70° C   |
| 7151M-20            | 7151M-20 | Tubes              | 8-pin SOIC | 0 to +70° C   |
| 7151M-20T           | 7151M-20 | Tape and Reel      | 8-pin SOIC | 0 to +70° C   |
| 7151M-20LF          | 51M-20LF | Tubes              | 8-pin SOIC | 0 to +70° C   |
| 7151M-20LFT         | 51M-20LF | Tape and Reel      | 8-pin SOIC | 0 to +70° C   |
| 7151M-40            | 7151M-40 | Tubes              | 8-pin SOIC | 0 to +70° C   |
| 7151M-40T           | 7151M-40 | Tape and Reel      | 8-pin SOIC | 0 to +70° C   |
| 7151M-40LF          | 51M-40LF | Tubes              | 8-pin SOIC | 0 to +70° C   |
| 7151M-40LFT         | 51M-40LF | Tape and Reel      | 8-pin SOIC | 0 to +70° C   |
| 7151M-50            | 7151M-50 | Tubes              | 8-pin SOIC | 0 to +70° C   |
| 7151M-50T           | 7151M-50 | Tape and Reel      | 8-pin SOIC | 0 to +70° C   |
| 7151M-50LF          | 51M-50LF | Tubes              | 8-pin SOIC | 0 to +70° C   |
| 7151M-50LFT         | 51M-50LF | Tape and Reel      | 8-pin SOIC | 0 to +70° C   |
| 7151MI-10           | 7151MI10 | Tubes              | 8-pin SOIC | -40 to +85° C |
| 7151MI-10T          | 7151MI10 | Tape and Reel      | 8-pin SOIC | -40 to +85° C |
| 7151MI-10LF         | 51MI10LF | Tubes              | 8-pin SOIC | -40 to +85° C |
| 7151MI-10LFT        | 51MI10LF | Tape and Reel      | 8-pin SOIC | -40 to +85° C |
| 7151MI-20           | 7151MI20 | Tubes              | 8-pin SOIC | -40 to +85° C |
| 7151MI-20T          | 7151MI20 | Tape and Reel      | 8-pin SOIC | -40 to +85° C |
| 7151MI-20LF         | 51MI20LF | Tubes              | 8-pin SOIC | -40 to +85° C |
| 7151MI-20LFT        | 51MI20LF | Tape and Reel      | 8-pin SOIC | -40 to +85° C |
| 7151MI-40           | 7151MI40 | Tubes              | 8-pin SOIC | -40 to +85° C |
| 7151MI-40T          | 7151MI40 | Tape and Reel      | 8-pin SOIC | -40 to +85° C |
| 7151MI-40LF         | 51MI40LF | Tubes              | 8-pin SOIC | -40 to +85° C |
| 7151MI-40LFT        | 51MI40LF | Tape and Reel      | 8-pin SOIC | -40 to +85° C |
| 7151MI-50           | 7151MI50 | Tubes              | 8-pin SOIC | -40 to +85° C |
| 7151MI-50T          | 7151MI50 | Tape and Reel      | 8-pin SOIC | -40 to +85° C |
| 7151MI-50LF         | 51MI50LF | Tubes              | 8-pin SOIC | -40 to +85° C |
| 7151MI-50LFT        | 51MI50LF | Tape and Reel      | 8-pin SOIC | -40 to +85° C |

Parts that are ordered with a “LF” suffix to the part number are the Pb-Free configuration and are RoHS compliant.

While the information presented herein has been checked for both accuracy and reliability, Integrated Device Technology (IDT) assumes no responsibility for either its use or for the infringement of any patents or other rights of third parties, which would result from its use. No other circuits, patents, or licenses are implied. This product is intended for use in normal commercial applications. Any other applications such as those requiring extended temperature range, high reliability, or other extraordinary environmental requirements are not recommended without additional processing by IDT. IDT reserves the right to change any circuitry or specifications without notice. IDT does not authorize or warrant any IDT product for use in life support devices or critical medical instruments.



Innovate with IDT and accelerate your future networks. Contact:

**www.IDT.com**

**For Sales**

800-345-7015  
408-284-8200  
Fax: 408-284-2775

**For Tech Support**

408-284-4522  
clockhelp@idt.com

---

**Corporate Headquarters**

Integrated Device Technology, Inc.  
www.idt.com



www.IDT.com