

GAU205S-15252 Universal Gate Drive Prototype Board

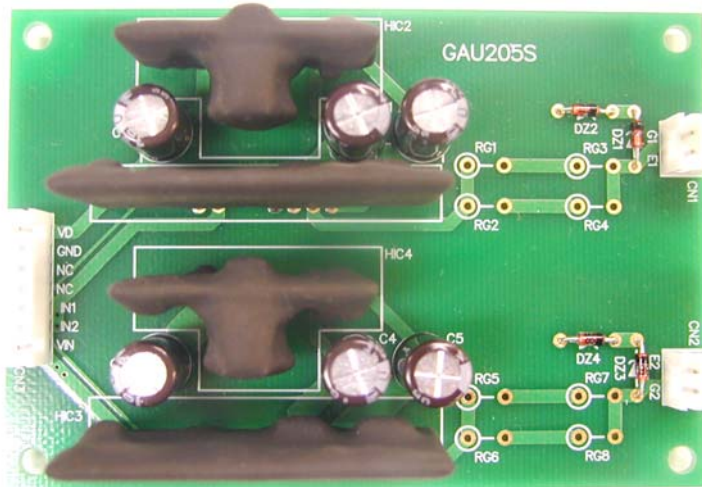

Size : 65 x 95 x 34t

Gate Driver : VLA513-01R

DC-DC Converter : VLA106-15242

FEATURE

- >Built in the isolated DC-DC converter for gate drive
- >Output peak current is +/-5A(max)
- >Electrical isolation voltage is 2500Vrms (for 1 minute)
- >Two way power supply system for drivers and input signal (VD=15V , VIN=5V)
- >CMOS compatible input interface

RECOMMENDED IGBT MODULES

MITSUBISHI NFH series IGBT modules

VCES = 600V series ~ 400A class

VCES = 1200V series ~ 400A class

VCES = 600V series ~ 200A class

VCES = 1200V series ~ 200A class

MITSUBISHI NF series IGBT modules

VCES = 600V series ~ 600A class

VCES = 1200V series ~ 400A class

BLOCK DIAGRAM

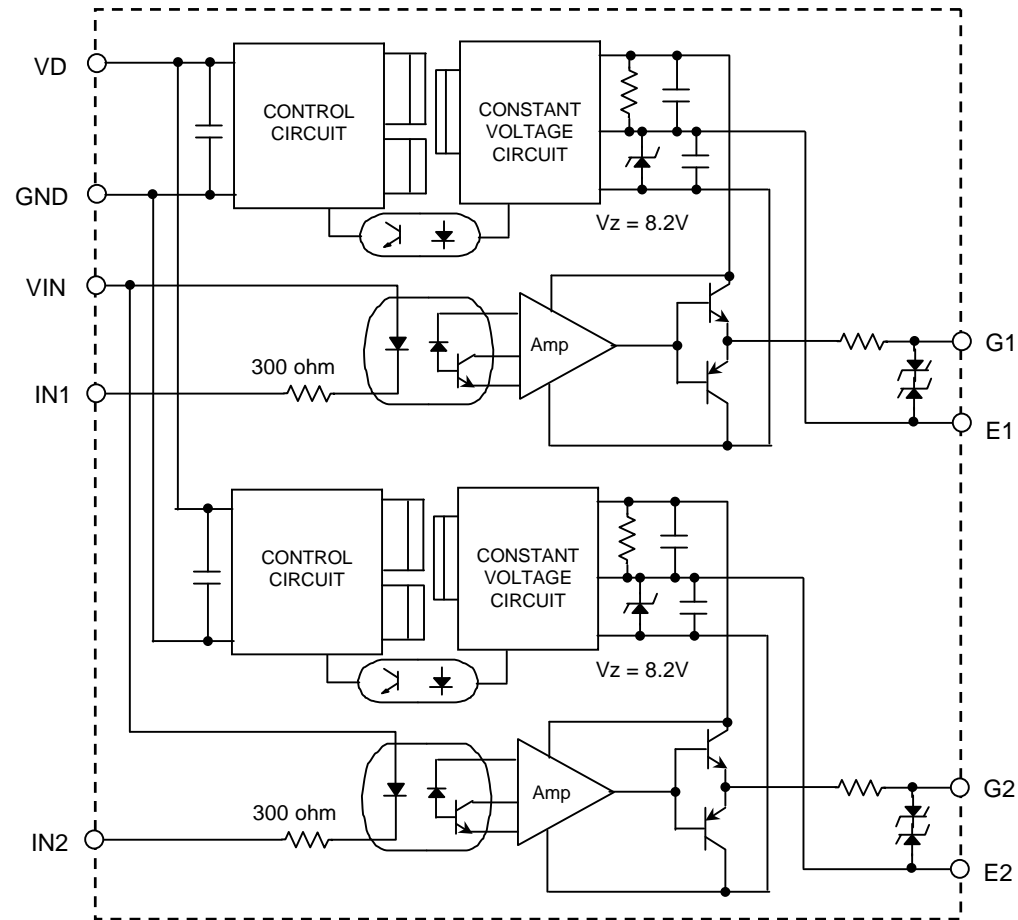

MAXIMUM RATINGS

(unless otherwise noted, Ta=25°C)

Symbol	Parameter	Conditions	Ratings	Unit
VD	Supply voltage	DC	18	V
VI	Input signal voltage	Applied between VIN – IN1,2 50% Duty cycle , pulse width 1ms	-1 ~+7	V
IOHP	Output peak current	Pulse width 2us	-5	A
IOLP			5	A
Viso	Isolation voltage	Sine wave voltage 60Hz, for 1min	2500	Vrms
Topr	Operating temperature	No condensation allowable	-10 ~ 70	°C
Tstg	Storage temperature	No condensation allowable	-25 ~ 85	°C
Idrive	Gate drive current	Gate average current (Per one circuit)	90	mA

ELECTRICAL CHARACTERISTICS

(unless otherwise noted, Ta=25°C, VD=15V)

Symbol	Parameter	Conditions	Limits			Unit
			Min	Typ	Max	
VD	Supply voltage	Recommended range	12	15	18	V
VIN	Pull-up voltage on input side	Recommended range	4.75	5	5.25	V
IIH	"H" input signal current	Recommended range	9.5	10	14	mA
f	Switching frequency	Recommended range	-	-	60	kHz
RG	Gate resistance	Recommended range	2	-	-	ohm
VOH	Plus bias voltage	-	13.5	15	16.5	V
VOL	Minus bias voltage	-	-9.6	-8.0	-6.5	V
tPLH	"L-H" propagation time	IIH = 10mA	-	0.2	0.5	us
tPHL	"H-L" propagation time	IIH = 10mA	-	0.2	0.5	us



INNER CIRCUIT

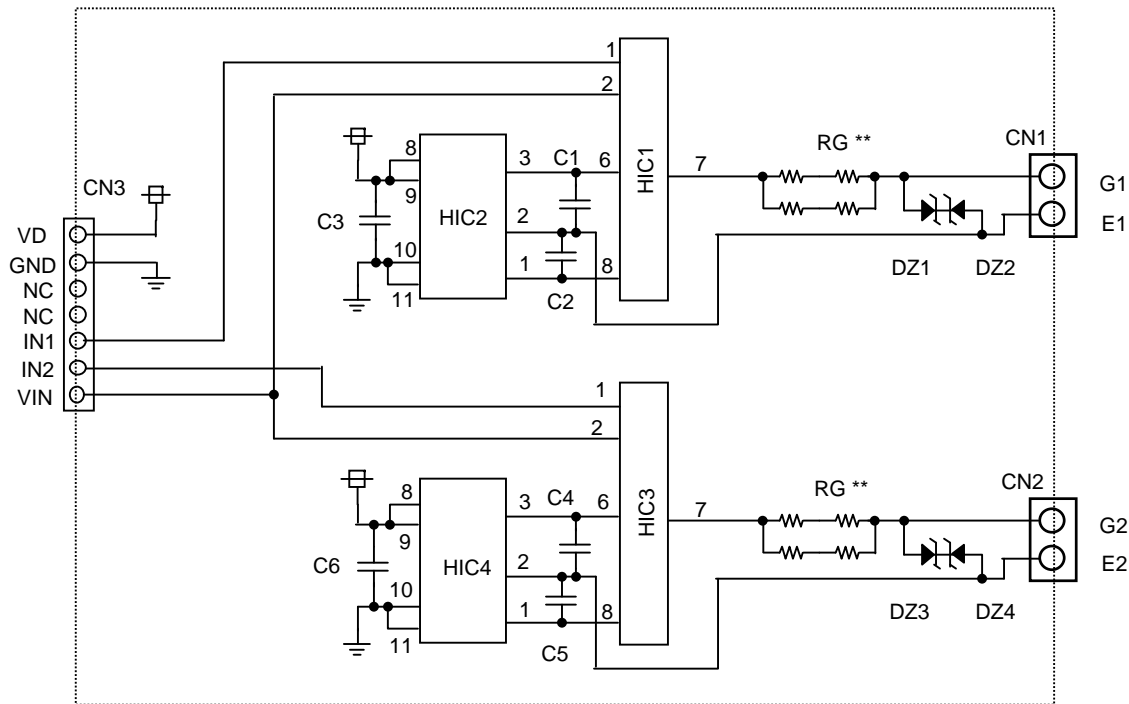

HIC1,3	VLA513-01R	ISAHAYA
HIC2,4	VLA106-15242	ISAHAYA
DZ1,2,3,4	Vz=18V,500mW	
RG	Gate Resistor	
CN1,2	B2B-XH-A	JST
CN3	B7B-XH-A	JST
C1,2,4,5	220uF,35V	Low impedance
C3,6	100uF,50V	Low impedance

****) Gate Resistor is not installed at the time of shipment.
Please solder the chosen resistor.**

APPLICATION EXAMPLE

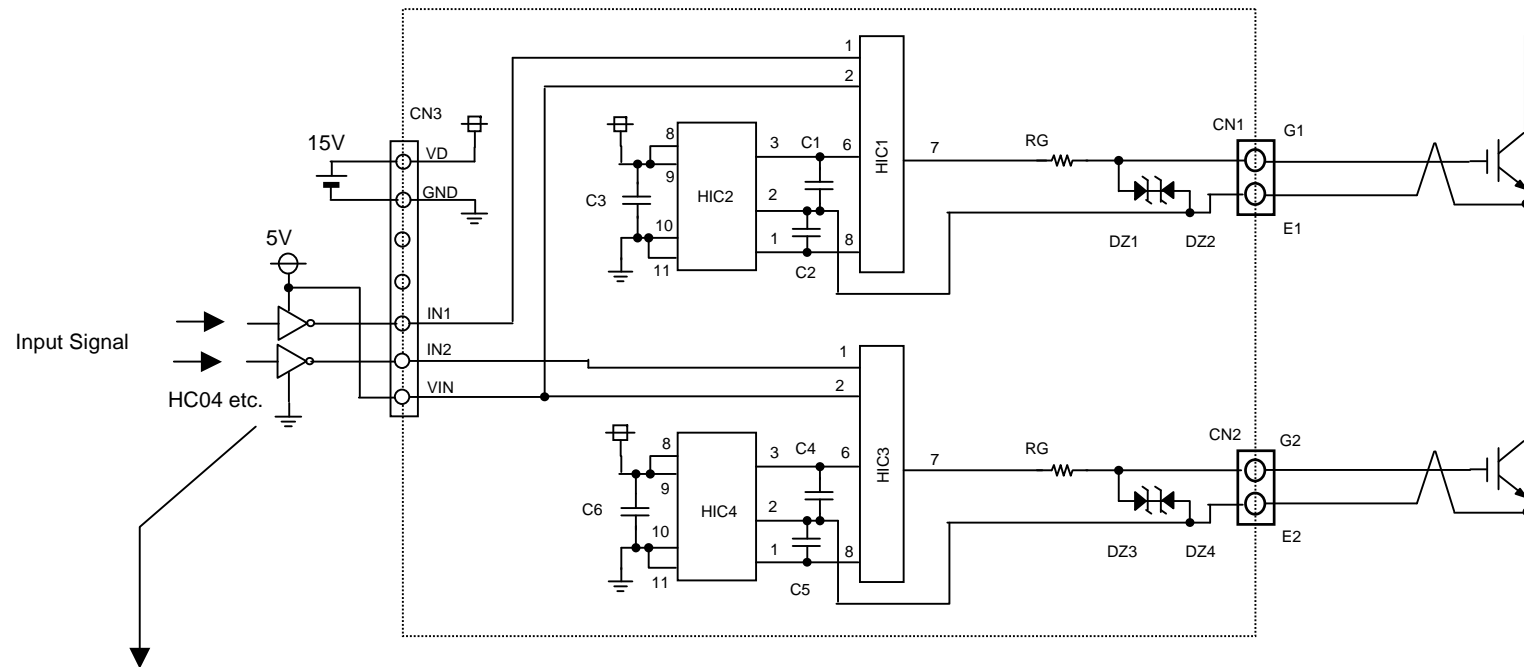

**Open-collector(drain) type is not recommended.

PRECATION

(1) Confirmation of gate average current

The maximum rating of output current capacity per one circuit of the gate power supply built-in this product is 100mA. And the steady-state consumption current of the gate driver is about 10mA. Therefore the gate average current must be less than 90mA.

Please calculate the gate average current by the following expression.

$$I_{drive} = (Q1 + |Q2|) \times f$$

I_{drive} : Gate average current

$Q1$: Gate charge on plus bias (Please read it from data sheet of IGBT)

$Q2$: Gate charge on minus bias (Please read it from data sheet of IGBT)

f : Switching frequency

(2) Electric power setting of gate resistance

At the time of the choice of gate resistance, please choose the resistance which can permit the electric power by the following calculation.

$$P_d = I_{drive} \times V_{24}$$

P_d : Total allowable power loss of gate resistance

I_{drive} : Gate average current

V_{24} : Total output voltage of gate power supply

Part arrangement & Size

