

**SURFACE MOUNT
THYRISTOR SURGE PROTECTIVE DEVICE**

Bi-Directional
VDRM - **58 to 320** Volts
IPP - **100** Amperes

FEATURES

- Oxide Glass Passivated Junction
- Bidirectional protection in a single device
- Surge capabilities up to 100A @ 10/1000us or 400 @ 8/20us
- High off state Impedance and low on state voltage
- Plastic material has UL flammability classification 94V-0

MECHANICAL DATA

- Case : Molded plastic
- Polarity : Denotes none cathode band
- Weight : 0.093 grams

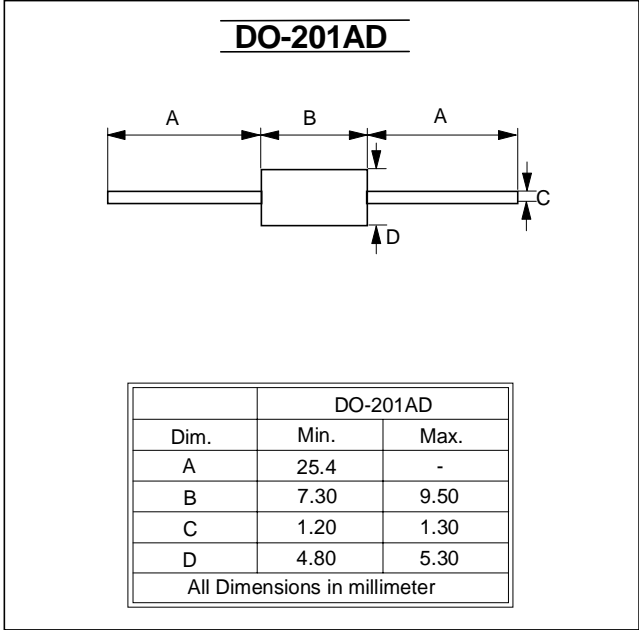

MAXIMUM RATINGS

CHARACTERISTICS	SYMBOL	VALUE	UNIT
Non-repetitive peak impulse current @ 10/1000us	IPP	100	A
Non-repetitive peak On-state current @ 8.3ms (one half cycle)	ITSM	50	A
Junction temperature range	TJ	-40 to +150	°C
storage temperature range	TSTG	-55 to +150	°C

THERMAL RESISTANCE

CHARACTERISTICS	SYMBOL	VALUE	UNIT
Junction to leads	Rth(J-L)	20	°C/W
Junction to ambient on print circuit (on recommended pad layout)	Rth(J-A)	100	°C/W
Typical positive temperature coefficient for brekdown voltage	$\Delta V_{BR}/\Delta T_J$	0.1	%/°C

MAXIMUM RATED SURGE WAVEFORM

WAVEFORM	STANDARD	IPP (A)
2/10 us	GR-1089-CORE	500
8/20 us	IEC 61000-4-5	400
10/160 us	FCC Part 68	250
10/700 us	ITU-T K20/21	200
10/560 us	FCC Part 68	160
10/1000 us	GR-1089-CORE	100

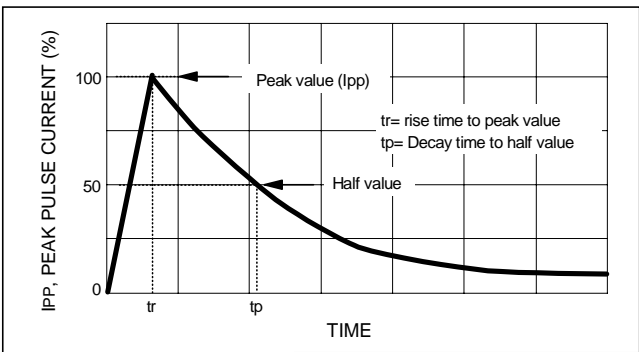

**ELECTRICAL CHARACTERISTICS @ TA= 25°C unless otherwise specified
TL0640H thru TL3500H**



PARAMETER	RATED REPETITIVE OFF-STATE VOLTAGE	OFF-STATE LEAKAGE CURRENT @ VDRM	BREAKOVER VOLTAGE	ON-STATE VOLTAGE @ IT=1.0A	BREAKOVER CURRENT		HOLDING CURRENT		OFF-STATE CAPACITANCE
					IBO-	IBO+	IH-	IH+	
SYMBOL	VDRM	IDRM	VBO	VT	IBO-	IBO+	IH-	IH+	Co
UNITS	Volts	uA	Volts	Volts	mA	mA	mA	mA	pF
LIMIT	Max	Max	Max	Max	Min	Max	Min	Max	Typ
TL0640H	58	5	77	3.5	50	800	150	800	200
TL0720H	65	5	88	3.5	50	800	150	800	200
TL0900H	75	5	98	3.5	50	800	150	800	200
TL1100H	90	5	130	3.5	50	800	150	800	120
TL1300H	120	5	160	3.5	50	800	150	800	120
TL1500H	140	5	180	3.5	50	800	150	800	120
TL1800H	160	5	220	3.5	50	800	150	800	120
TL2300H	190	5	265	3.5	50	800	150	800	80
TL2600H	220	5	300	3.5	50	800	150	800	80
TL3100H	275	5	350	3.5	50	800	150	800	80
TL3500H	320	5	400	3.5	50	800	150	800	80

SYMBOL	PARAMETER
VDRM	Stand-off Voltage
IDRM	Leakage current at stand-off voltage
VBR	Breakdown voltage
IBR	Breakdown current
VBO	Breakover voltage
IBO	Breakover current
IH	Holding current Note: 1
VT	On state voltage
IPP	Peak pulse current
CO	Off state capacitance Note: 2

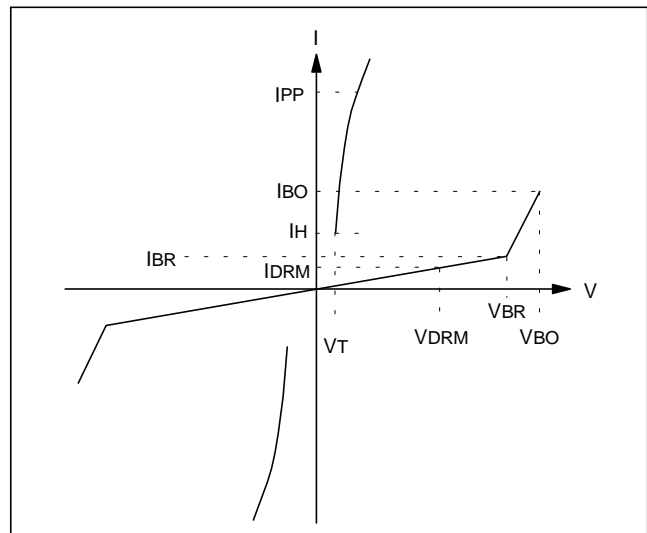

REV. 0, 03-Dec-2001, KDWE01

NOTES: 1. $I_H > (V_L/R_L)$ If this criterion is not obeyed, the TSPD Triggers but does not return correctly to high-resistance state. The Surge recovery time does not exceed 30ms.
2. Off-state capacitance measured at $f=1.0\text{MHz}$; $1.0V_{RMS}$ signal; $V_R=2V_{DC}$ bias.

FIG. 1 - OFF STATE CURRENT vs JUNCTION TEMPERATURE **FIG. 2 - RELATIVE VARIATION OF BREAKDOWN VOLTAGE vs JUNCTION TEMPERATURE**

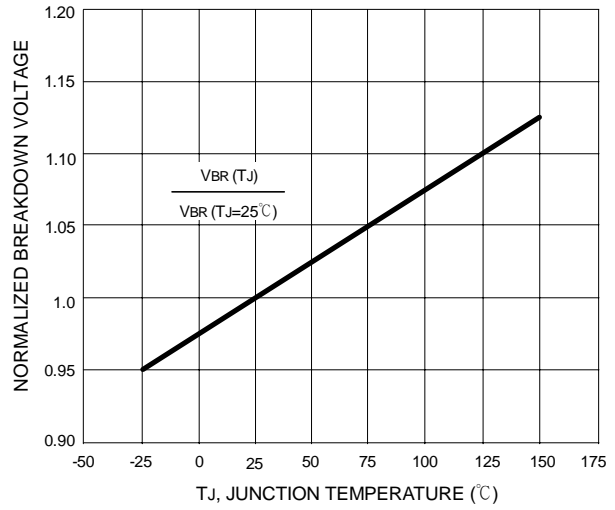
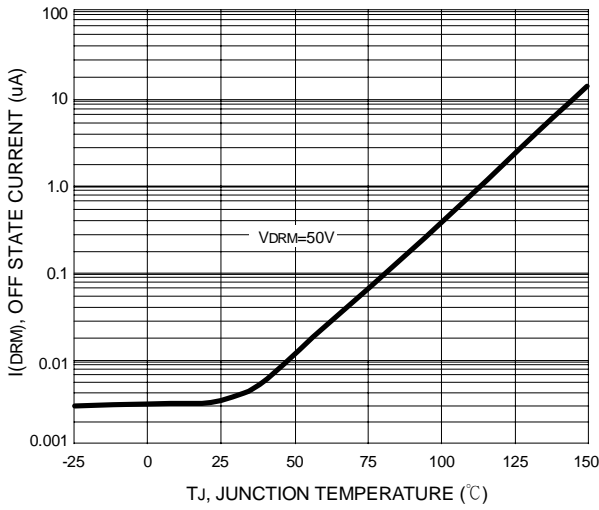

FIG. 3 - RELATIVE VARIATION OF BREAKOVER VOLTAGE vs JUNCTION TEMPERATURE

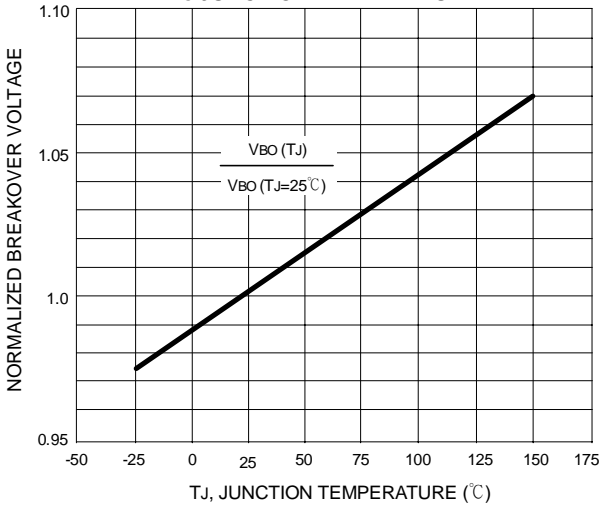

FIG. 4 - ON STATE CURRENT vs ON STATE VOLTAGE

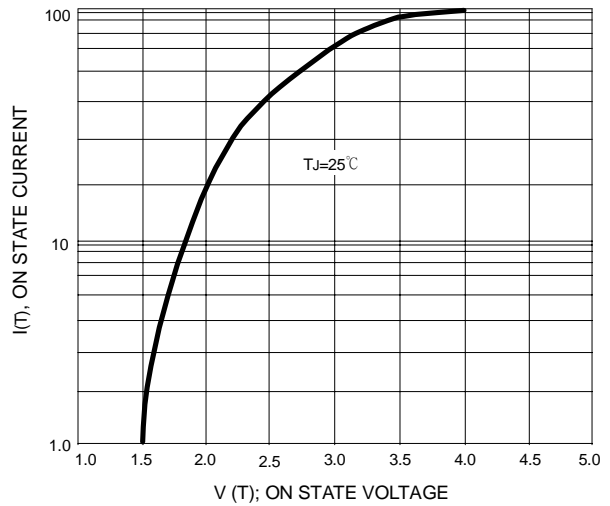

FIG. 5 - RELATIVE VARIATION OF HOLDING CURRENT vs JUNCTION TEMPERATURE

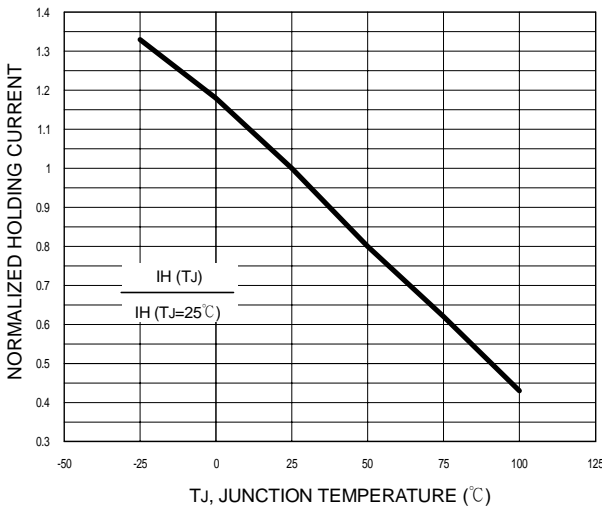
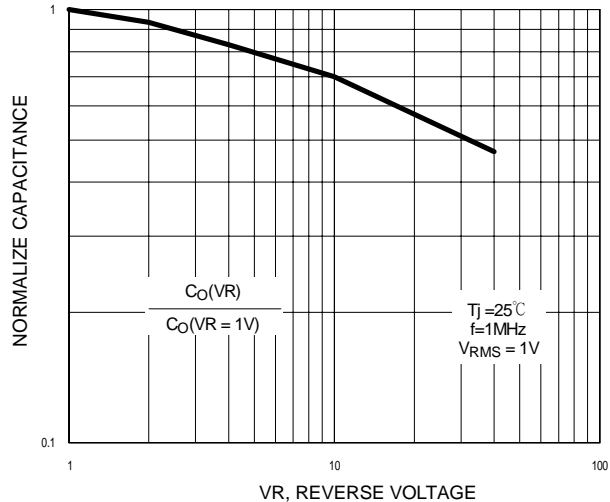
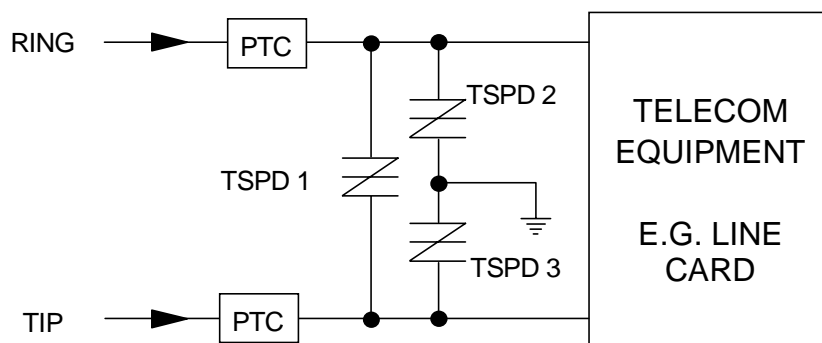
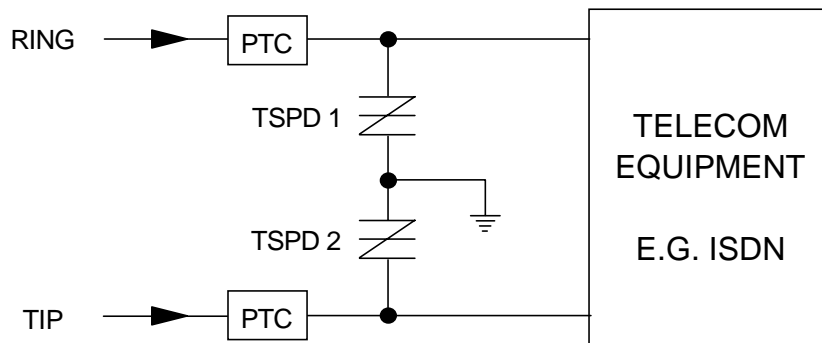
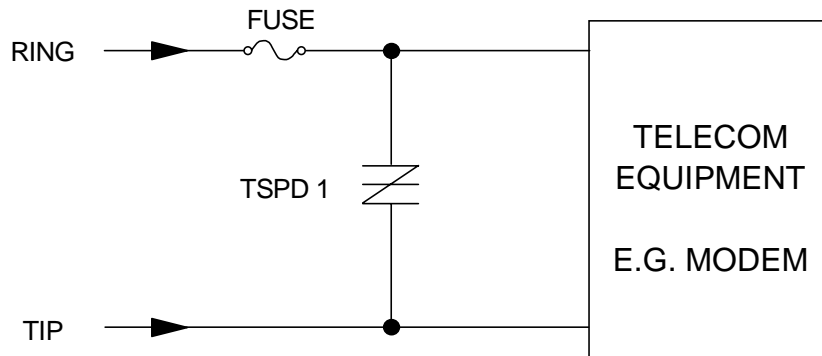

FIG. 6 - RELATIVE VARIATION OF JUNCTION CAPACITANCE vs REVERSE VOLTAGE BIAS





The PTC (Positive Temperature Coefficient) is an overcurrent protection device