

MATED WITH: PASSEND ZU:	LOC A1	DIST —	REVISIONS ÄNDERUNGEN DESCRIPTION BESCHREIBUNG			DATE	DWN	APVD
PROJEKT NR.: —			P	LTR		22MAR11	RK	HMR
			A1	REVISED PER ECO-11-005150				

Customer Drawing  
for PN 1703013

SEE 1703020

RELEASED FOR PUBLICATION  
FREI FÜR VERÖFFENTLICHUNG  
ALL RIGHTS RESERVED.

THIS DRAWING IS UNPUBLISHED.  
VERTRAULICHE UNVERÖFFENTLICHTE ZEICHNUNG.

By —  
COPYRIGHT —

—	—	—	—	—	—	—
CUSTOMER PART NO	PART NO	REV.	PCS.	MATERIAL	SURFACE COLOR	DESCRIPTION

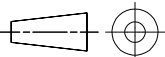
DIMENSIONS: MASSENEHTEINHEITEN mm  TOLERANCES UNLESS OTHERWISE SPECIFIED: ALLGEMEINTOLERANZEN ISO 8015 P. ISO 2768 - MH - E P. DIN 16901 - 140 0 PLC ± - 1 PLC ± - 2 PLC ± - 3 PLC ± - 4 PLC ± - ANGLES / WINKEL ± -	DWN Abraham,G. 04-FEB-04	MATERIAL	FINISH OBERFLÄCHE/FARBE	—
	CHK Goepfel,C. 05-FEB-04	 TE Connectivity		
APVD Bleicher,M. 06-FEB-04	NAME DIA. 1.5mm PIN CONTACT, SINGLE WIRE SEALING DIA 1.5mm Stiftkontakt, Einzeldichtungssystem			
PRODUCT SPEC PRODUKTSPEZ. —	SIZE A4	CAGE CODE 00779	DRAWING NO ZEICHNUNGS-NR. C-1703013	RESTRICTED TO NUR FUER —
APPLICATION SPEC VERARBEITUNGSSPEZ. —	CUSTOMER DRAWING / KUNDENZEICHNUNG			SCALE MASSSTAB
WEIGHT GEWICHT —	SHEET BLATT			1 OF 1 VON
			REV A1	