

2SD1611

■ Features

- High forward current transfer ratio h_{FE}
- High collector-base voltage (Emitter open) V_{CB0}

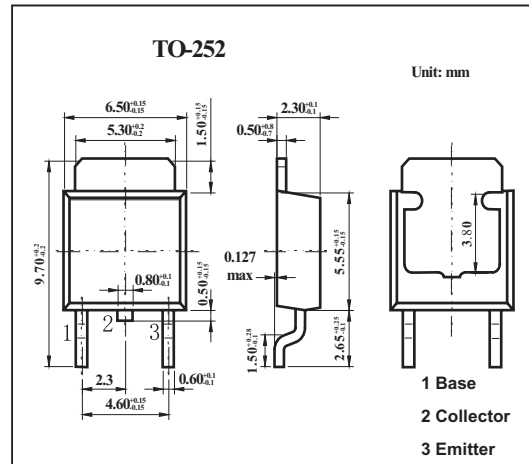

■ Internal Connection

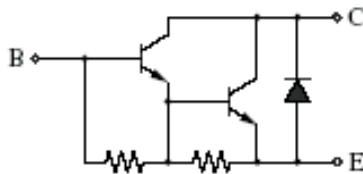

■ Absolute Maximum Ratings $T_a = 25^\circ\text{C}$

Parameter	Symbol	Rating	Unit
Collector-base voltage (Emitter open)	V_{CB0}	500	V
Collector-emitter voltage (Base open)	V_{CE0}	400	V
Emitter-base voltage (Collector open)	V_{EB0}	5	V
Collector current	I_C	6	A
Peak collector current	I_{CP}	10	A
Collector power dissipation $T_a = 25^\circ\text{C}$	P_C	40	A
		1.3	W
Junction temperature	T_j	150	$^\circ\text{C}$
Storage temperature	T_{stg}	-55 to +150	$^\circ\text{C}$

■ Electrical Characteristics Ta = 25°C

Parameter	Symbol	Testconditons	Min	Typ	Max	Unit
Emitter-base voltage (Collector open)	VEBO	IE = 0.1 A, IC = 0	5			V
Collector-emitter sustaining voltage*	VCE0(SUS)	IC = 2 A, L = 10 mH	400			V
Collector-base cutoff current (Emitter open)	ICBO	VCB = 350 V, IE = 0			100	μA
Forward current transfer ratio	hFE	VCE = 2 V, IC = 2 A	500			
Collector-emitter saturation voltage	VCE(sat)	IC = 3 A, IB = 0.06 A			1.5	V
Base-emitter saturation voltage	VBE(sat)	IC = 3 A, IB = 0.06 A			2.5	V
Transition frequency	fT	VCE = 10 V, IC = 1 A, f = 1 MHz		15		MHz

*. VCE0(SUS) Test circuit

