



N-Channel 240-V (D-S) MOSFETs

PRODUCT SUMMARY				
Part Number	$V_{(BR)DSS}$ Min (V)	$r_{DS(on)}$ Max (Ω)	$V_{GS(th)}$ (V)	I_D (A)
TN2410L	240	10 @ $V_{GS} = 4.5$ V	0.5 to 1.8	0.18
VN2406D		6 @ $V_{GS} = 10$ V	0.8 to 2	1.12
VN2406L		6 @ $V_{GS} = 10$ V	0.8 to 2	0.18
VN2410L		10 @ $V_{GS} = 10$ V	0.8 to 2	0.18
VN2410LS		10 @ $V_{GS} = 10$ V	0.8 to 2	0.19

FEATURES

- Low On-Resistance: 3.5 Ω
- Secondary Breakdown Free: 260 V
- Low Power/Voltage Driven
- Low Input and Output Leakage
- Excellent Thermal Stability

BENEFITS

- Low Offset Voltage
- Full-Voltage Operation
- Easily Driven Without Buffer
- Low Error Voltage
- No High-Temperature "Run-Away"

APPLICATIONS

- High-Voltage Drivers: Relays, Solenoids, Lamps, Hammers, Displays, Transistors, etc.
- Telephone Mute Switches, Ringer Circuits
- Power Supply, Converters
- Motor Control

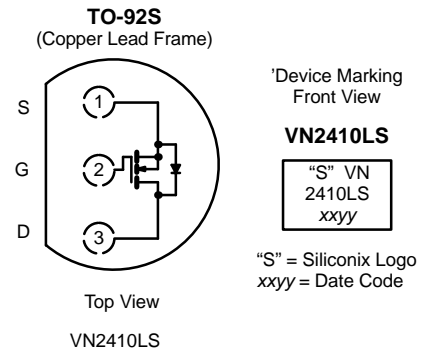
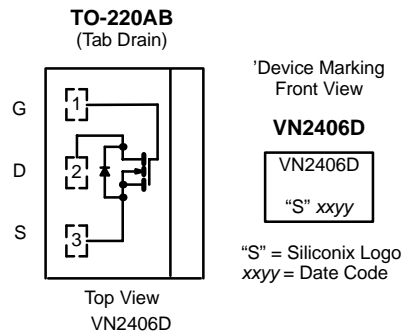
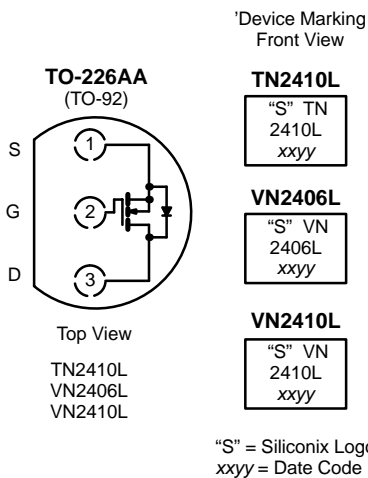

ABSOLUTE MAXIMUM RATINGS ($T_A = 25^\circ\text{C}$ UNLESS OTHERWISE NOTED)							
Parameter	Symbol	TN2410L	VN2406D ^b	VN2406L	VN2410L	VN2410LS	Unit
Drain-Source Voltage	V_{DS}	240	240	240	240	240	V
Gate-Source Voltage	V_{GS}	± 20	± 20	± 20	± 20	± 20	
Continuous Drain Current ($T_J = 150^\circ\text{C}$)	$T_A = 25^\circ\text{C}$	I_D	0.18	1.12	0.18	0.18	A
	$T_A = 100^\circ\text{C}$		0.11	0.7	0.11	0.11	
Pulsed Drain Current ^a	I_{DM}	1	3	1.7	1.7	2	
Power Dissipation	$T_A = 25^\circ\text{C}$	P_D	0.8	20	0.8	0.8	W
	$T_A = 100^\circ\text{C}$		0.32	8	0.32	0.32	
Thermal Resistance, Junction-to-Ambient	R_{thJA}	156	6.25 ^c	156	156	139	$^\circ\text{C/W}$
Operating Junction and Storage Temperature Range	T_J, T_{stg}	-55 to 150					$^\circ\text{C}$

Notes

- Pulse width limited by maximum junction temperature.
- Reference case for all temperature testing.
- Maximum junction-to-case

SPECIFICATIONS (T _A = 25 °C UNLESS OTHERWISE NOTED)										
Parameter	Symbol	Test Conditions	Typ ^a	Limits						Unit
				TN2410L		VN2406D/L		VN2410L/LS		
				Min	Max	Min	Max	Min	Max	
Static										
Drain-Source Breakdown Voltage	V _{(BR)DSS}	V _{GS} = 0 V, I _D = 100 μA	260	240		240		240		V
Gate-Threshold Voltage	V _{GS(th)}	V _{DS} = V _{GS} , I _D = 1 mA	1.4	0.5	1.8	0.8	2	0.8	2	
Gate-Body Leakage	I _{GSS}	V _{DS} = 0 V, V _{GS} = ±15 V					±100		±100	nA
		T _J = 125 °C					±500		±500	
Zero Gate Voltage Drain Current	I _{DSS}	V _{DS} = 192 V, V _{GS} = 0 V	0.01		1					μA
		T _J = 125 °C	1		100					
		V _{DS} = 120 V, V _{GS} = 0 V					10		10	
On-State Drain Current ^b	I _{D(on)}	V _{DS} = 10 V, V _{GS} = 4.5 V	0.8	0.25						A
		V _{DS} = 15 V, V _{GS} = 10 V	1.5			1		1		
Drain-Source On-Resistance ^b	r _{DS(on)}	V _{GS} = 2.5 V, I _D = 0.1 A	7.5				10		10	Ω
		V _{GS} = 3.5 V, I _D = 0.05 A	4.5		15					
		V _{GS} = 4.5 V, I _D = 0.2 A	4		10					
		T _J = 125 °C	7.5		20					
		V _{GS} = 10 V, I _D = 0.5 A	3.5				6		10	
Forward Transconductance ^b	g _{fs}	V _{DS} = 10 V, I _D = 0.2 A	500	100						mS
		V _{DS} = 10 V, I _D = 0.5 A	530			300		300		
Input Capacitance	C _{iss}	V _{DS} = 25 V, V _{GS} = 0 V f = 1 MHz	115		135		135		135	pF
Output Capacitance	C _{oss}		30		50		50		50	
Reverse Transfer Capacitance	C _{riss}		5		20		20		20	
Switching^c										
Turn-On Time	t _{ON}	V _{DD} = 60 V, R _L = 150 Ω I _D ≅ 0.4 A, V _{GEN} = 10 V R _G = 25 Ω	5		35					ns
	t _{d(on)}		3				8		8	
	t _r		2				8		8	
Turn-Off Time	t _{OFF}		26		60					
	t _{d(off)}		20				23		23	
	t _f		6				34		34	

Notes

- a. For DESIGN AID ONLY, not subject to production testing.
- b. Pulse test: PW ≤ 300 μs duty cycle ≤ 2%.
- c. Switching time is essentially independent of operating temperature.

VNDB24



TYPICAL CHARACTERISTICS ($T_A = 25^\circ\text{C}$ UNLESS OTHERWISE NOTED)

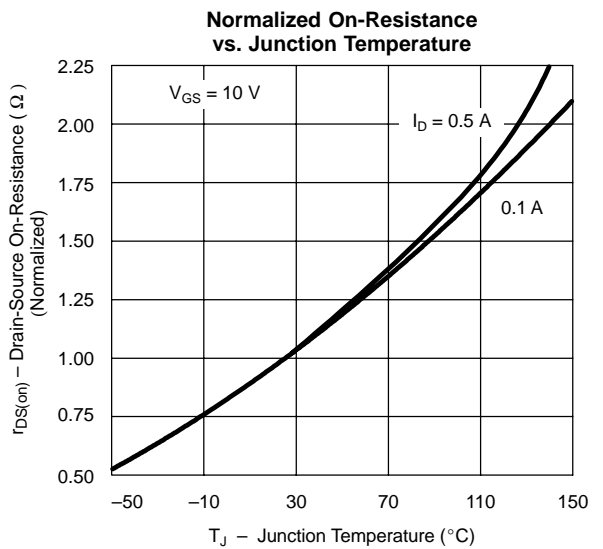
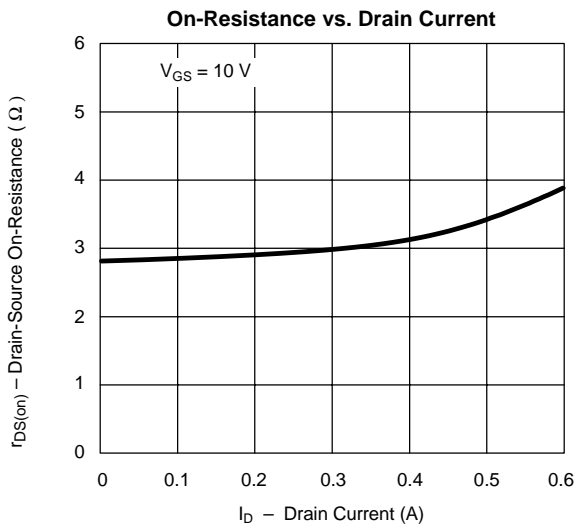
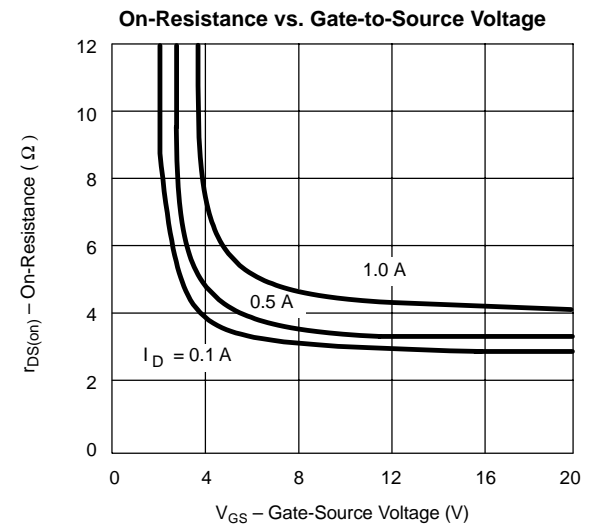
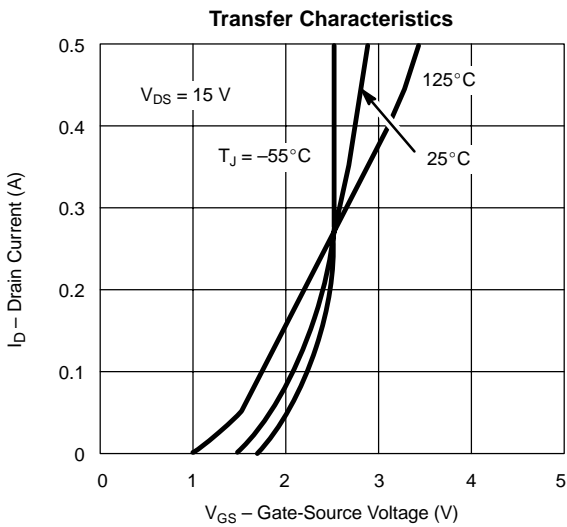
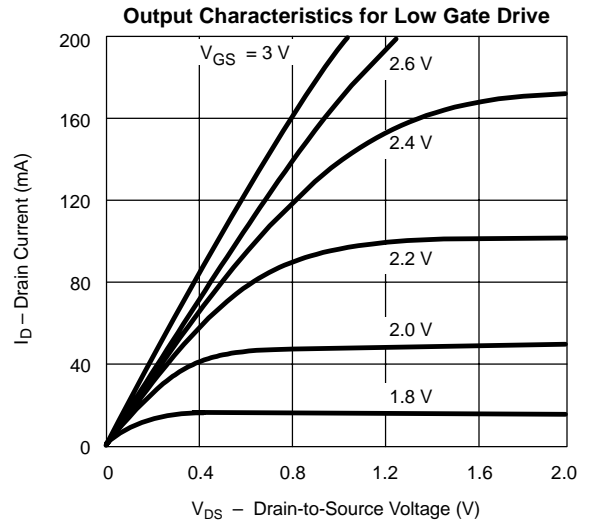
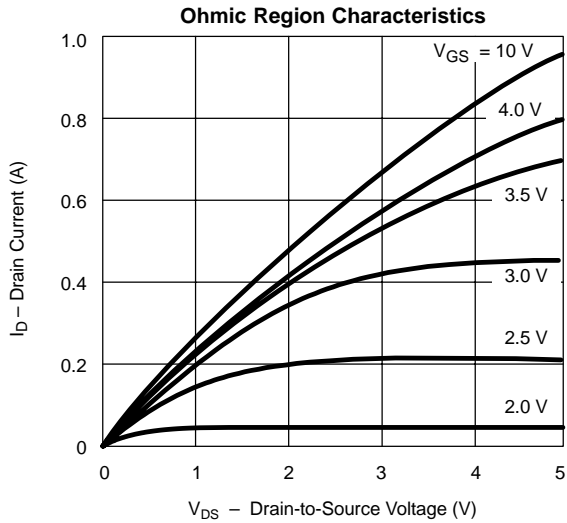

TYPICAL CHARACTERISTICS ($T_A = 25^\circ\text{C}$ UNLESS OTHERWISE NOTED)

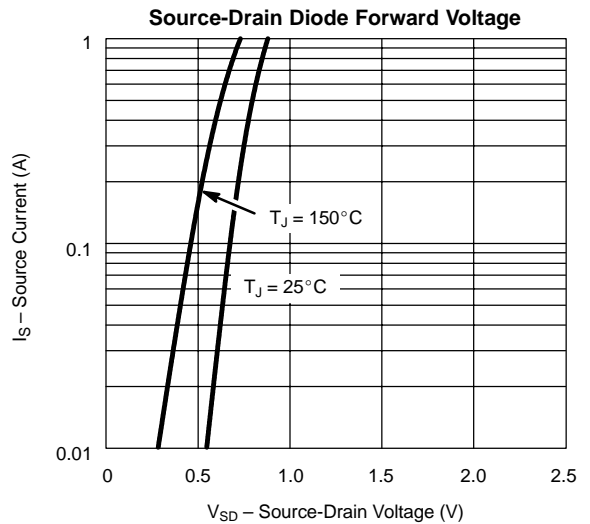
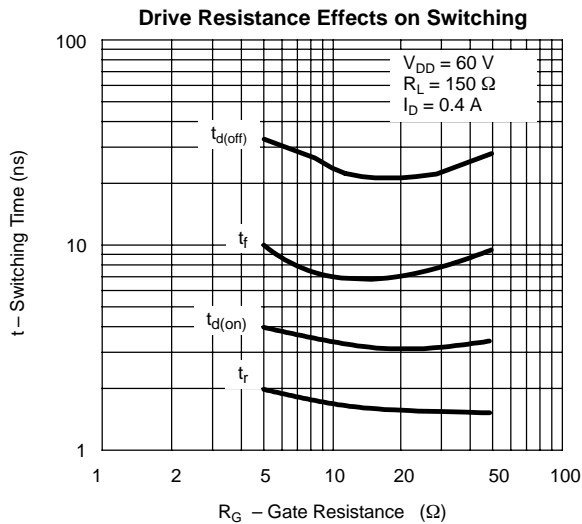
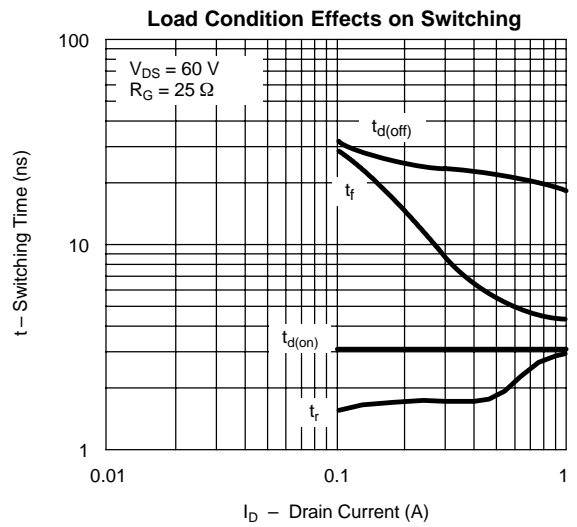
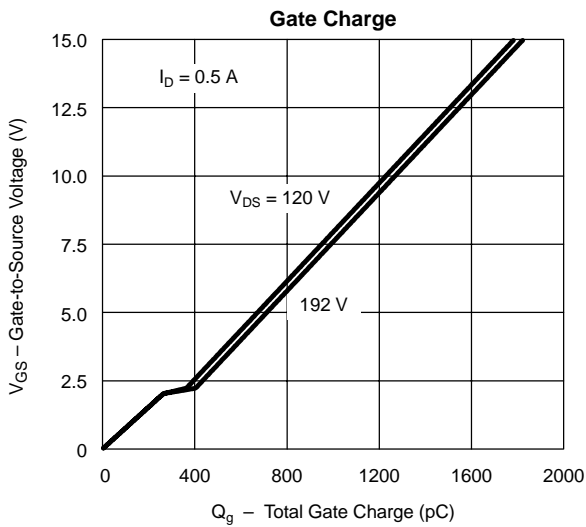
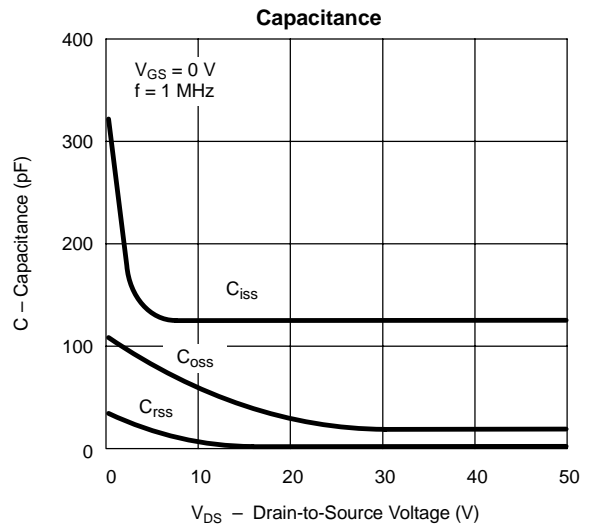
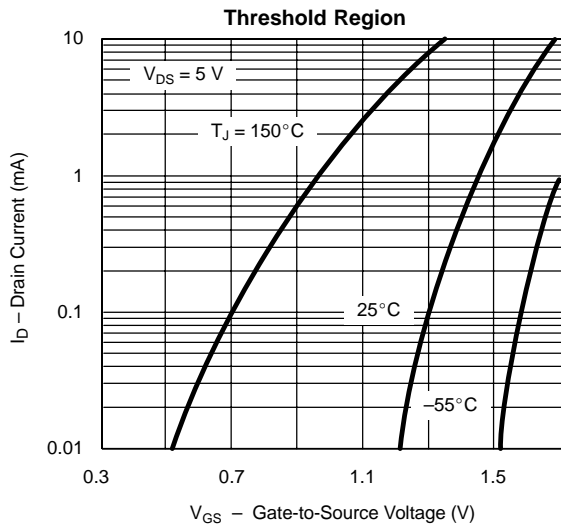



TYPICAL CHARACTERISTICS ($T_A = 25^\circ\text{C}$ UNLESS OTHERWISE NOTED)

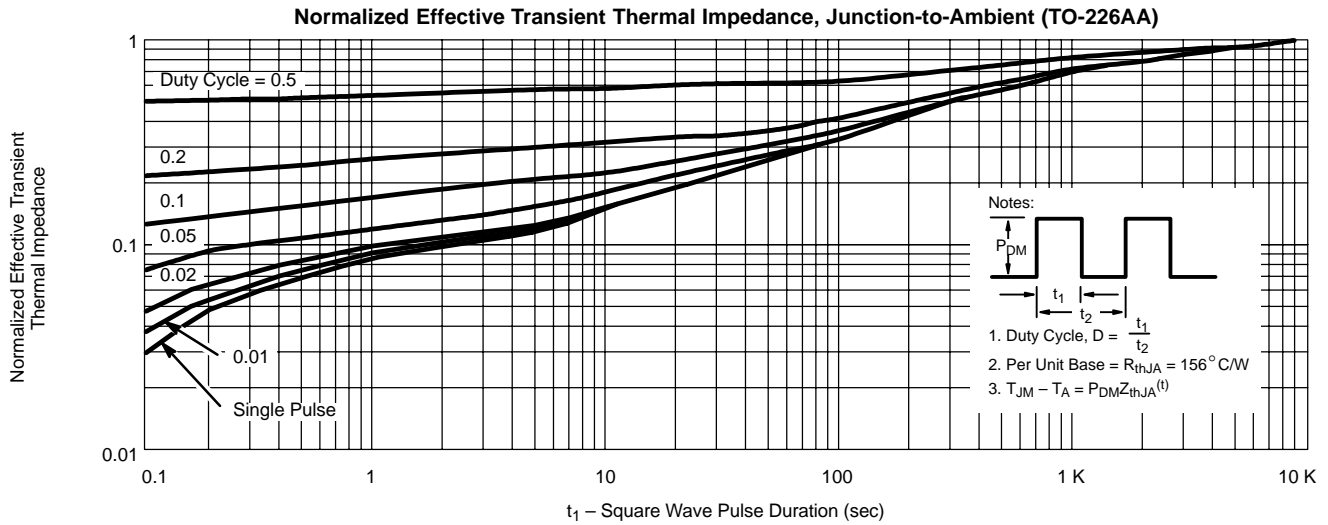



Disclaimer

All product specifications and data are subject to change without notice.

Vishay Intertechnology, Inc., its affiliates, agents, and employees, and all persons acting on its or their behalf (collectively, "Vishay"), disclaim any and all liability for any errors, inaccuracies or incompleteness contained herein or in any other disclosure relating to any product.

Vishay disclaims any and all liability arising out of the use or application of any product described herein or of any information provided herein to the maximum extent permitted by law. The product specifications do not expand or otherwise modify Vishay's terms and conditions of purchase, including but not limited to the warranty expressed therein, which apply to these products.

No license, express or implied, by estoppel or otherwise, to any intellectual property rights is granted by this document or by any conduct of Vishay.

The products shown herein are not designed for use in medical, life-saving, or life-sustaining applications unless otherwise expressly indicated. Customers using or selling Vishay products not expressly indicated for use in such applications do so entirely at their own risk and agree to fully indemnify Vishay for any damages arising or resulting from such use or sale. Please contact authorized Vishay personnel to obtain written terms and conditions regarding products designed for such applications.

Product names and markings noted herein may be trademarks of their respective owners.