

IN-SITU ZIRCONIA OXYGEN ANALYZER <ZIRCOMAT-P>

DATA SHEET

ZFK, ZRM

This oxygen analyzer is used to continuously measure oxygen concentration in combustible exhaust gas of industrial boilers or furnaces, and is ideally suited for combustion monitoring and control.

The detector (ZFK) used with the analyzer is directly inserted into the objects measured, eliminating the need for a sampling device and provides quick response.

The converter (ZRM) features automatic calibration and blowdown functions. The adoption of liquid crystal display facilitates operation and setting in interactive mode.

Besides the general-use type detector, corrosion resisting type and high temperature type are available for selection according to applications.

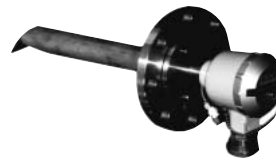

General-use detector



High-temperature detector



Converter

FEATURES

1. Output range easily set

Output range can be easily set in 0.5% increments within the scope of 2 to 50%. When oxygen decreases, incomplete combustion level appears on the display (rich mode; output voltage of oxygen detector), instead of oxygen concentration.

2. Automatic calibration/blowdown function

Automatic calibration and manual/auto blowdown functions are provided as standard functions. An external solenoid valve is required.

3. Easily operated in interactive mode

Interactive mode is adopted to the liquid crystal display for operation and parameter setting, facilitating use even for beginners.

4. Combustion efficiency display function

Combustion efficiency calculated from oxygen concentration and temperature of exhaust gas can be displayed as an optional function, which is useful to improve combustion efficiency.

5. Sampling device is unnecessary

Gas sampling devices such as a gas aspirator, a dehumidifier, etc. are unnecessary because of use of direct-insertion type detector. The adoption of a flow guide tube utilizing the flow of the measured gas assures quick response (less than 7sec).

6. Selection of detector type according to applications

Besides the general-use type detector used under temperatures of less than 600°C, a corrosion-proof detector for measuring incinerator exhaust gas, and a high temperature type detector using heat insulator for the ejector and insertion tube, capable of measuring temperatures up to 1590°C, are available for selection according to applications.

SPECIFICATIONS

General

Measuring object: Oxygen contained in noncombustible gas

Measuring principle:

Direct-insertion zirconia system

Measuring range: 0 to 250 vol% O₂ freely settable (in 0.5% steps)

Repeatability: Within ±0.5% of max. output signal

Linearity: ±2% of full scale

Response time: Within 7sec for 90% response (from calibration gas inlet)

Power supply: 100, 115, 220 or 230V AC, 50/60Hz

Power consumption:
(approx.) 15 + 50VA (at steady state of general-use detector)

15 + 200VA (at start of general-use detector)

Warmup time: Approx. 15min

Oxygen detector (ZFK2,5), ejector (ZTA)

Measuring detector:

For general-use: ZFK2

For corrosive gas: ZFK5

Measured gas temperature:

Flow guide tube system; -20 to +600°C
(for general-use, corrosive gas)
Ejector system; -20 to +1590 °C (for
high-temperature gas)
-20 to +800°C (for general-use)

Measured gas pressure:

-3 to +3kPa (-306 to +306mmH₂O)

Flow guide tube:

With or without blow-down nozzle
Flange; JIS5K 65A FF
(JIS5K-80AFF for high particulate gas)
Insertion length; 0.3, 0.5, 0.75, 1m
(0.8m for high particulate gas)

Ejector (general-use):

Probe for guiding measured gas to de-
tector
Flange; JIS10K 65A RF
Insertion length; 0.5, 0.75, 1, 1.5m
(according to customer's specification)

Ambient temperature:

-20 to +60°C for cable section
-5 to +100°C for ejector section
125°C or less at detector flange surface
with power applied

Structure:

Dust/rain-proof structure(IEC IP55
equivalent)

Filter:

Alumina(filtering accuracy 50μm) and
quartz paper

Main materials of gas-contacting parts:

General-use detector; Zirconia, SUS316,
platinum
Anticorrosive detector; Zirconia, tita-
nium, platinum
Flow guide tube; SUS304 or SUS316
Ejector (general use);SUS316, SUS304
Ejector; (for high temperature) SiC,
SUS316, SUS304

Calibration gas inlet:

SUS316

Reference air inlet (option):

Rc1/8 or NPT1/8

Detector mounting:

Horizontal plane ±45°, ambient sur-
rounding air should be clean.

Outer dimensions: (L x max. dia.) 210mm x 100mm

(detector)

Mass (approx.) {weight}:

Detector; 1.6kg
Ejector; 15kg (insertion length 1m)
Flow guide tube (general-use, 1m); 5kg

Finish color:

Silver and SUS metallic color

Ejector air inlet flow rate:

5 to 10 ℓ /min

Blowdown air inlet pressure:

200 to 300kPa {2 to 3 kgf/cm²}

Ejector exhaust gas processing:

Within furnace, returned to flue

Heater temperature drop alarm output (ejector):

Alarm output when below 100 °C
Mechanical thermostat
N.O. (1a) contact, 200V AC, 2A

Oxygen converter (ZRM)

Measuring range: 0 to 250 vol% O₂ freely settable
(in 0.5% O₂ steps)

Repeatability: ±0.5% of full scale

Linearity: ±1.0% of full scale

Indication: Oxygen concentration; 3-digit LED
Operation/setting display: 16-digit, 2-line
LCD
Mode display: 3pcs LED

Oxygen concentration output signal:

4 to 20mA DC (allowable load resistance:
500Ω or less)
or 0 to 1V (output resistance: 100Ω or
less)
Isolated output, linear

Contact output signal:

(1) Contact specification; 4 points, N.O. (1a), 250V AC, 2A

(2) Contact function;

- Under maintenance
- Under blowdown
- Span calibrating gas
- Zero calibration gas

Following functions freely selected

- High limit alarm
- Low limit alarm
- High/low limit alarm
- Fault (abnormal)

Contact input signal:

Auto. calibration start (auto. calibration
starts when contact closes)

Calibration disable (calibration disabled
when contact closes)

Contact specification; isolated, ON at
1kΩ or less

Calibration method:

(a) Manual calibration with key operation
(b) Auto. calibration (standard function)
Calibration cycle; 00 day 00 hour to 90
days 60 hours

Calibration gas:

• Range settings
Zero gas; 0.010 to 50.000% O₂
Span gas; 8.000 to 23.000% O₂

- Recommended calibration gas concen-
tration

Zero gas; 0.25 to 2.0% O₂
Span gas; 20.6 to 21.0% O₂
(oxygen concentration in the
air)

Blowdown:

A function for blowing out with com-
pressed air dust that has deposited in the
flow guide tube. Blowdown can be
performed for a predetermined time and
at predetermined intervals.

Blowdown cycle; 00 hour 00 minute to
99 hours 60 minutes

Blowdown time; 0 minute 00 second to
9 minutes 60 seconds

Output signal hold:

Output signal is held during calibration
and blowdown. The hold function can
also be released.

Transmission function (option):

RS-485
Transmission distance; Max. 500m total
Number of units connected; Max. 8 units
Half-duplex bit serial transmission, start-
stop synchronization.

Remark: When connecting via an RS-232C interface, a RS232 ↔ RS 485 converter should be used.

Combustion efficiency display (option):

This function calculates and displays combustion efficiency from oxygen concentration and measured gas temperature.

Thermocouple (K or R) is required for temperature measurement.

Rich mode display:

When the detector output voltage exceeds 200mV (0.0023% O₂), the rich mode (fuel rich) is indicated in LCD where the LED showing the detector output voltage flickers.

Self-diagnosis function:

Provided for detector temperature fault, zero calibration fault, span calibration fault, calibration disable, and detector output fault.

Ambient temperature:

-10 to +50°C

Ambient humidity: 90% RH or less

Power supply: 90 to 220 or 230 V AC, 50/60Hz

Construction: Dust-proof, rainproof construction (corresponding to IP53 of IEC)

Material: Steel

Outer dimensions (H x W x D):

220 X 193 X 89mm

Mass (weight): Approx. 3.5kg (excluding cable and detector)

Finish color: Munsell 2.5Y8.4/1.2

Mounting method: Mounted flush on panel or on pipe

Electrical Safety:

Overvoltage category

; II power supply input

; I relay interfaces

(IEC1010-1)

External overcurrent protective device

; 10A

Equipment interfaces are safety separated (SELV)

The product conforms to the requirements of the Electromagnetic compatibility Directive 89/336/EEC as detailed within the technical construction file number TZ734575. The applicable standards used to demonstrate compliance are :

EN 55011 : 1992 CLASSA Conducted and Radiated emissions

EN 50082-1 : 1992 Radiated immunity, ESD and FBT

CODE SYMBOLS

(Detector)

ZFK	4	5	6	7	8	9	10	11	12	13	14	Description
					4							Description
												Application
		2										General use
		5										For corrosive gas (refuse incinerator)
												Kinds
											R	Standard
												Cal. gas inlet
											1	For ϕ 6mm tube
											2	For ϕ 1/4 inch tube
												Power supply
											1	100/115VAC 50/60Hz
											3	200/220VAC 50/60Hz
											5	230VAC 50/60Hz (CE-marking approved)
												Flow guide tube
												flange application length
											0 Y 0	None
											5 A 3	SUS304 general use 300mm
											5 A 5	SUS304 general use 500mm
											5 A 7	SUS304 general use 750mm
											5 A 1	SUS304 general use 1000mm
											5 B 3	SUS316 for corrosive gas 300mm
											5 B 5	SUS316 for corrosive gas 500mm
											5 B 7	SUS316 for corrosive gas 750mm
											5 B 1	SUS316 for corrosive gas 1000mm
											5 C 3	SUS316 with blow-down nozzle 300mm
											5 C 5	SUS316 with blow-down nozzle 500mm
											5 C 7	SUS316 with blow-down nozzle 750mm
											5 C 1	SUS316 with blow-down nozzle 1000mm
											6 D 3	SUS316 for high particulate 300mm
											6 D 5	SUS316 for high particulate 500mm
											6 D 7	SUS316 for high particulate 750mm
											6 D 1	SUS316 for high particulate 1000mm
											6 E 3	SUS316 for high particulate with cover 300mm
											6 E 5	SUS316 for high particulate with cover 500mm
											6 E 7	SUS316 for high particulate with cover 750mm
											6 E 1	SUS316 for high particulate with cover 1000mm
											Z Z Z	Others
												Protection cover
											Y	Without
											A	With
												Reference air inlet
											Y	Non
											A	Rc1/8
											B	NPT1/8
												Non-standard spec.
											Z	Other non-standard items

(Replacement Detector element)

ZFK	4	5	6	7	8	9	10	11	12	13	Description	
					4						Description	
											Application	
		2									General use (TC516041)	
		5									For corrosive gas (refer to incinerator) (TC516042)	
											Kinds	
											R	Standard
												Cal. gas inlet
											6	Polypropylene joint for ϕ 6 tube
											7	Brass joint for ϕ 1/4 inch tube
												Power supply
											1	100/115VAC 50/60Hz
											3	200/220VAC 50/60Hz
											5	230VAC 50/60Hz

(Ejector)

Z T A	1	2	3	4	5	6	7	8	Description
									Description
									Measured gas temperature
									For high temperatures (+1590°C max.)
									General-use (+800°C max.)
									Insertion length [mm]
									B 500
									C 750
									D 1000
									E 1500
									Power supply
									1 100V/115V AC 50/60Hz
									3 200V/220V AC 50/60Hz
									5 230VAC 50/60Hz

(Converter)

Z R M	1	2	3	4	5	6	7	8	9	Description
										Description
										Output signal
										B 4 to 20mA DC
										E 0 to 1V DC
										Optional functions
										Y None
										A Serial communication (RS-485)
										B Combustion efficiency display
										C Transmission function + Combustion efficiency display
										Power supply
										1 90 to 220V AC 50/60Hz
										5 230VAC 50/60Hz (CE marking approved)
										Mounting method
										1 Panel mounting
										2 Pipe mounting

Note: Specify the detector type.
(ZFK 2 or 5, R-type or K-type thermocouple)

(Exclusive-special cable)

Z R Z M	1	2	3	4	5	6	7	8	9	Description
										Description
										Connectable devices
										M For ZRM
										Types
										R For R thermocouple
										Conduit length Cable length
										YA None 6m
										YB None 10m
										YC None 15m
										YD None 20m
										YE None 30m
										YF None 40m
										YG None 50m
										YH None 60m
										YJ None 70m
										YK None 80m
										YL None 90m
										YM None 100m
										AA 6m 6m
										BB 10m 10m
										CC 15m 15m
										DD 20m 20m
										Cable end treatment
										0 None
										1 One side (detector side)
										2 Both sides

Note: For connection between detector and converter, the conduit to be used should be rainproof flexible type.

CONFIGURATION

Flow guide tube system

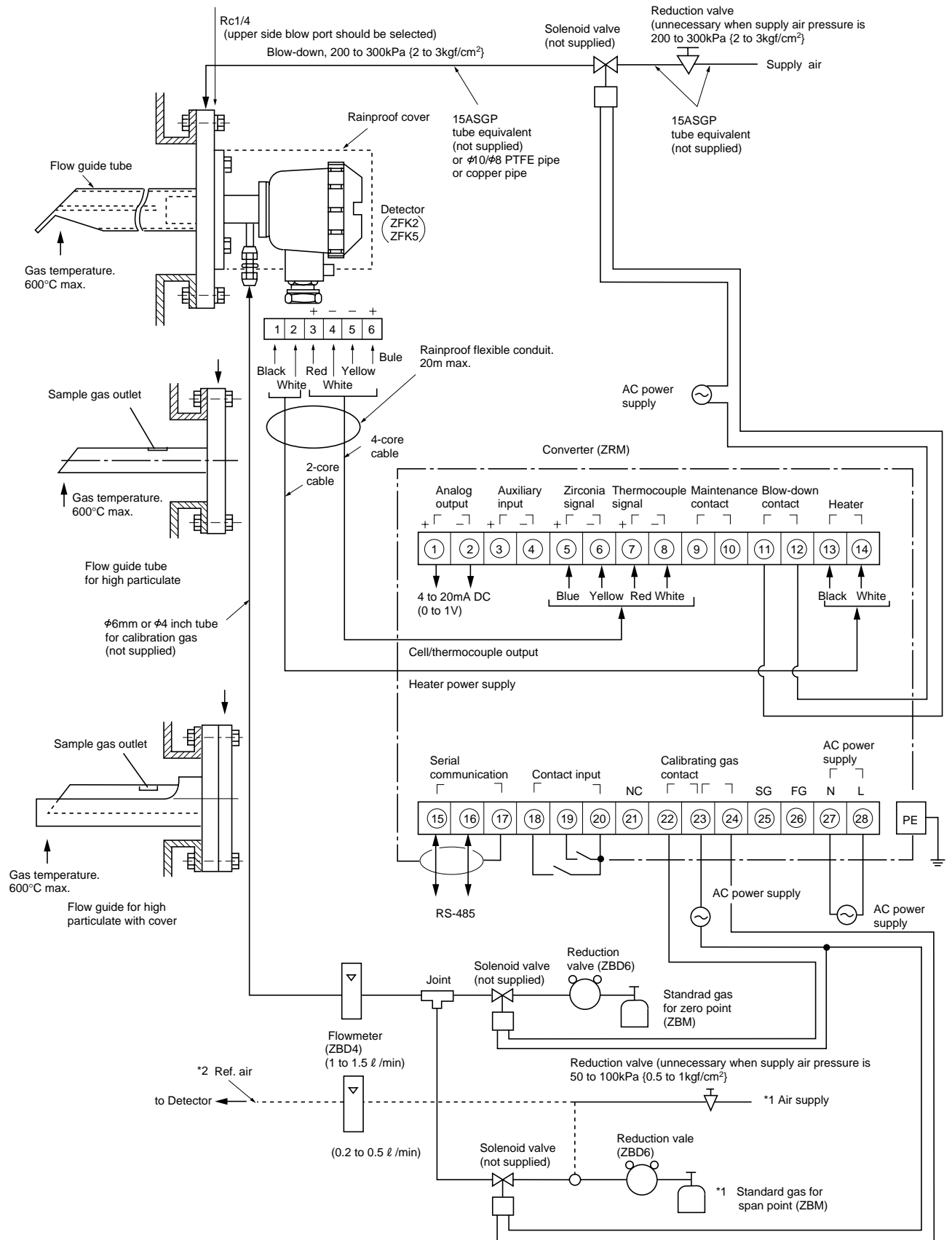

- Note
- *1 Standard gas or instrumentation air can be used in place of span gas.
 - *2 Instrument quality air or bottled air is available as reference air instead of ambient air.

Ejector system

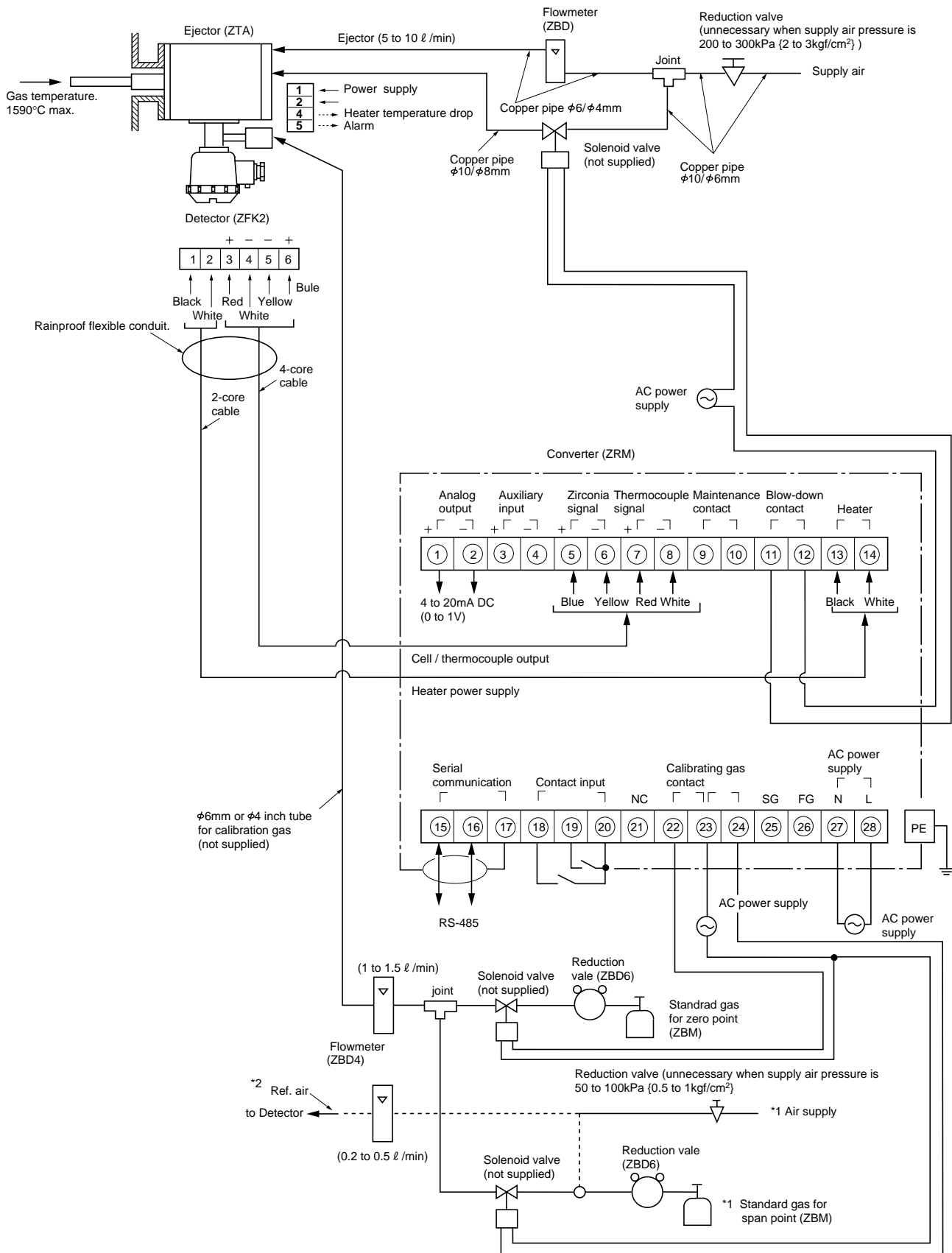

Note: *1 Standard gas or instrumentation air can be used in place of span gas.
 *2 Instrument quality air or bottled air is available as reference air instead of ambient air.

SCOPE OF DELIVERY

Detector:	Detector main unit x 1, Viton O ring x 2, mounting screw (M5mm x 16) x 6, thermal sticker x 1, flow guide tube (as specified) x 1, ceramic filter x 1, rainproof cover (as specified) x 1
Converter:	Converter main unit x 1, mounting bracket set, (according to specification) x 1 Accessories (AC250V 500mA T fuse x 2, AC250V 3.15A T fuse x 2)
Ejector:	Ejector main unit x 1, insertion tube x 1, M16mm nut, and washer x 4, packing x 1

Items to be prepared separately:

- (1) Standard gas for calibration
 - Type ZBM□NSH4-01 (up to 5% O₂ range)
 - Type ZBM□NSJ4-01 (over 5% O₂ range)
- (2) Reduction valve for standard gas (type ZBD61003)
- (3) Flowmeter
 - Type; ZBD42203, 0.2 to 2 ℓ /min (for calibrating gas)
 - Type; ZBD42403, 1 to 10 ℓ /min (for ejector)

CAUTIONS

- If combustible gas (CO, H₂ etc.) exists in the measured gas, error will occur due to burning at the sensor section. The inclusion of corrosive gas (Si vapor, alkaline metal, P, Pb etc.) will shorten the life of the sensor.
- When the measured gas temperature is high (+300°C or higher), the flange should be separated from the furnace wall in order to bring the detector flange surface temperature below the specified value +125°C). The flow guide should be attached in the direction in which the gas flow to the detector decreases.
- When much dust is included in the gas, the flow guide tube should be attached at an inclination so that the flow goes from below to above. And the flow guide should be attached in the direction in which the gas flow to the detector decreases.
- In the case of a refuse incinerator, automatic blow down of the flow guide should not be performed (to prevent corrosion of the flow guide tube due to drainage). Blow-down should be performed manually when change in the indication has become very little with the furnace stopped.

DEVICE CONFIGURATION

The device to be combined differ according to the conditions of the gas to be measured. Select the devices to be combined with reference to the following table.

Measured gas						Device configuration		
Application	Temperature	Gas Flow	DUST	Protection cover	Note	Detector type	Converter type	Ejector type
General-use (boiler)	600°C or less	5 to 20m/s	Less than 0.2g/mm ³	—	Fuel; gas, oil	ZFK2R□□4-□A□□□	ZRM	—
			Less than 10g/Nm ³	—	Fuel: coal with blow down	ZFK2R□□4-□C□□□	ZRM	—
For corrosive gas (refuse incinerator)	600°C or less	5 to 20m/s	Less than 1g/Nm ³	—	Included low moisture	ZFK5R□□4-□B□□□	ZRM	—
			Less than 10g/Nm ³	—	Included low moisture with blow down	ZFK5R□□4-□C□□□	ZRM	—
			Less than 25g/Nm ³	no	Included low moisture with blow down	ZFK5R□□4-□D□□□	ZRM	—
			Less than 25g/Nm ³	yes	Included high moisture with blow down	ZFK5R□□4-□E□□□	ZRM	—
General-use (boiler)	800°C or less	Less than 1m/s	Less than 1g/Nm ³	—	SUS316 tube with blow down	ZFK2R□□4-OYO□□	ZRM	ZTA2
	1590°C or less	Less than 1m/s	Less than 1g/Nm ³	—	SIC tube with blow down	ZFK2R□□4-OYO□□	ZRM	ZTA1

Note (1) Dust volume is approximate value.

(2) Instrument quality air or bottled air is available as reference air by selecting detector with reference air inlet.

OUTLINE DIAGRAM (Unit:mm)

Detector (ZFK2)

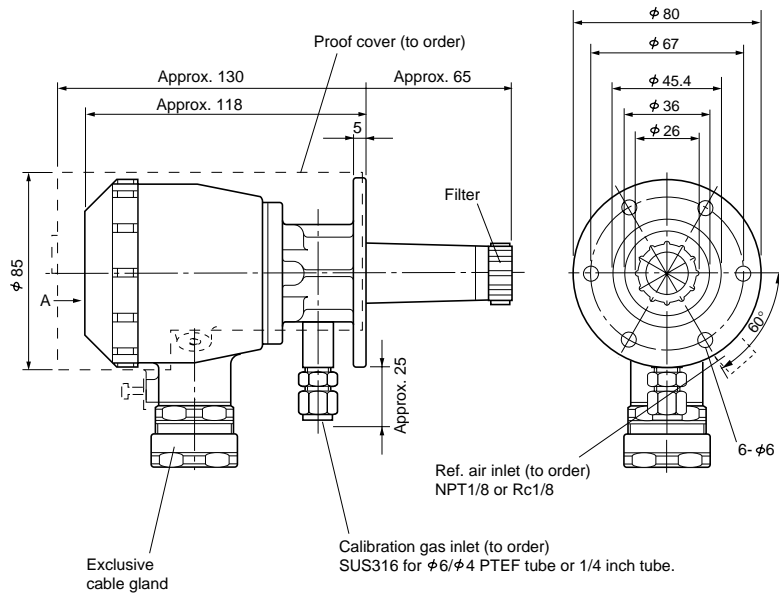

EXTERNAL CONNECTION DIAGRAM

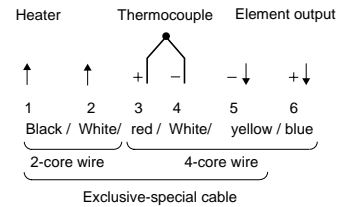

Flow guide tube

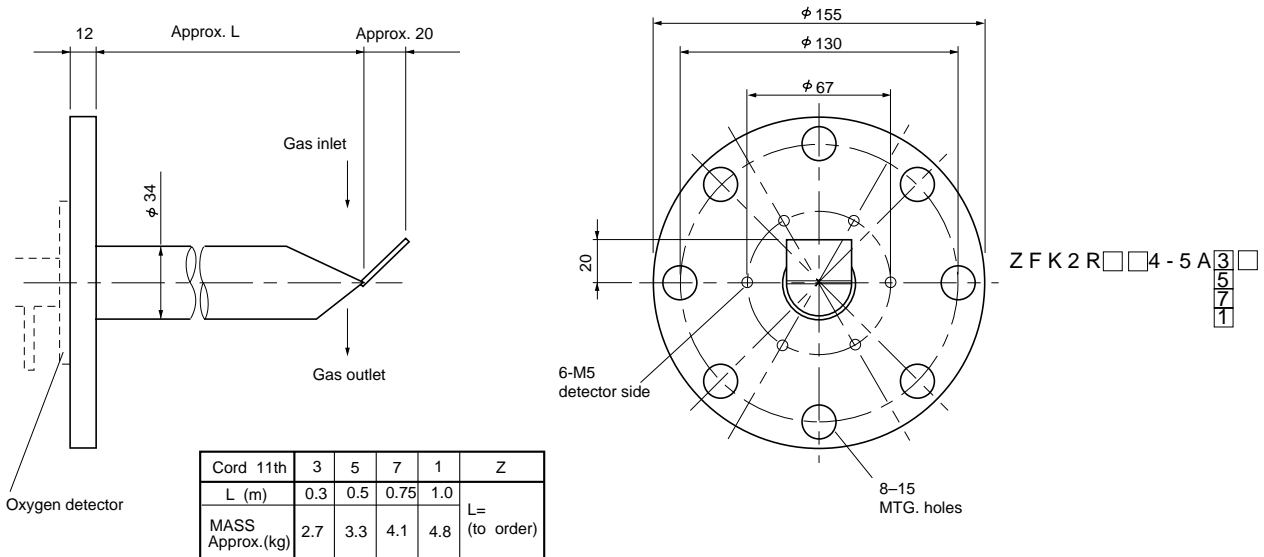

Flow guide tube (with blow-down nozzle)

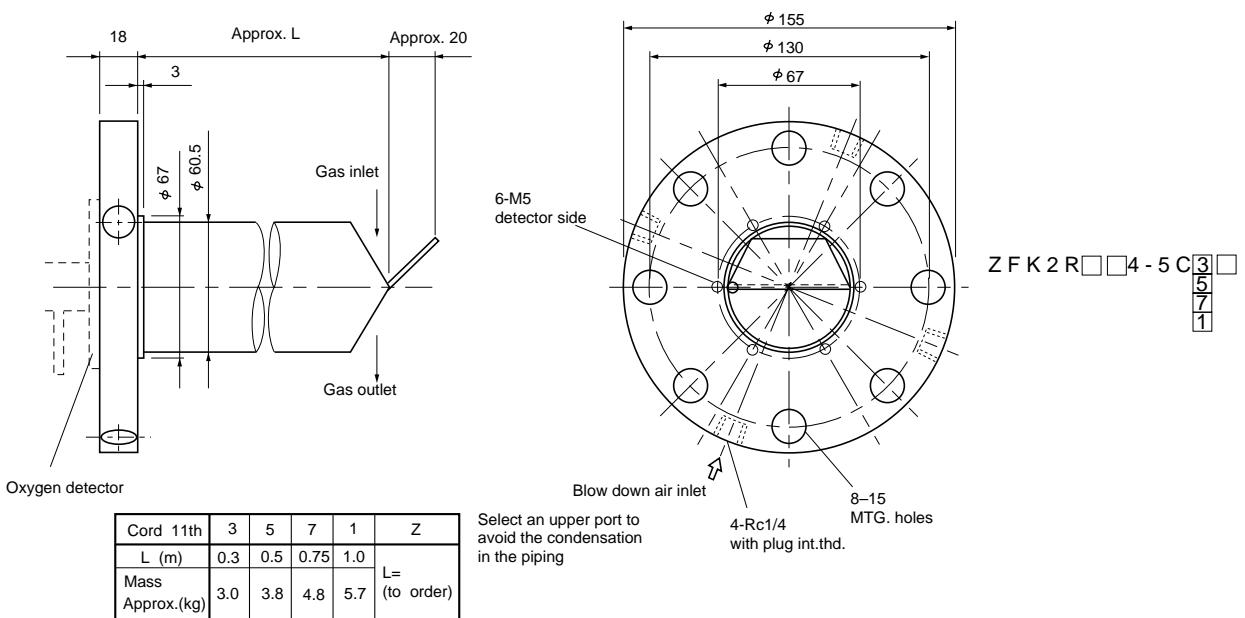

Flow guide tube (for high particulate)

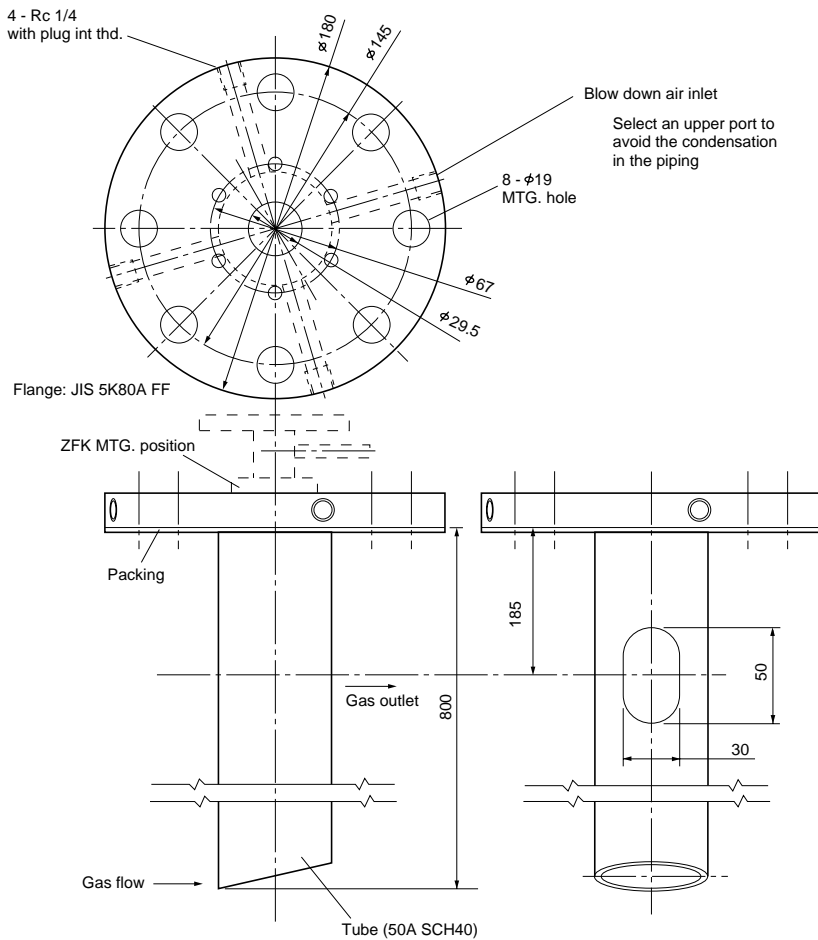

ZFK2R□□4-6D³₅₇₁

Cord 11th	3	5	7	1	Z
L (m)	0.3	0.5	0.75	1.0	L= (to order)
Mass Approx.(kg)	4.5	5.6	7.0	8.3	

Flow guide tube (for high particulate with cover)

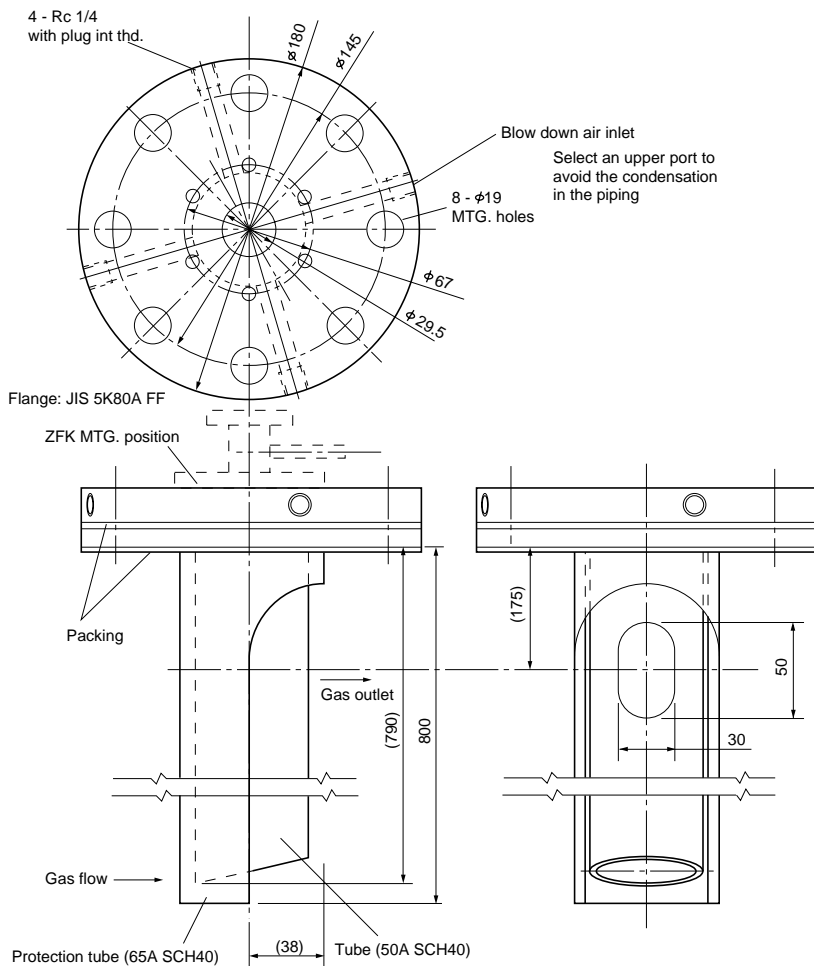

ZFK2R□□4-6E³₅₇₁

Cord 11th	3	5	7	1	Z
L (m)	0.3	0.5	0.75	1.0	L= (to order)
Mass Approx.(kg)	7.1	9.0	11.4	13.6	

Detector (ZFK5)

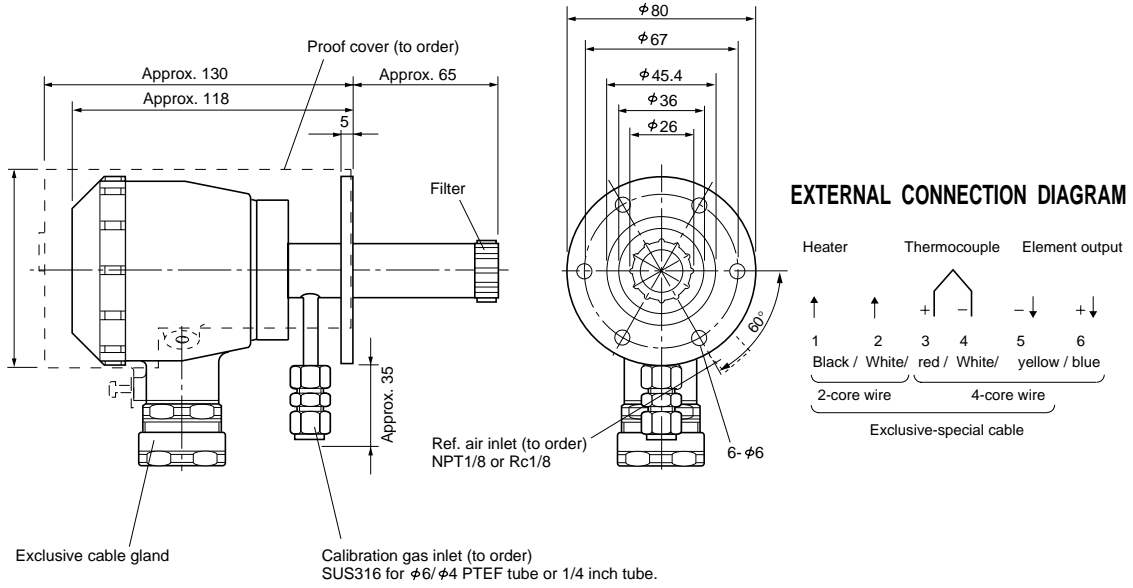

Flow guide tube

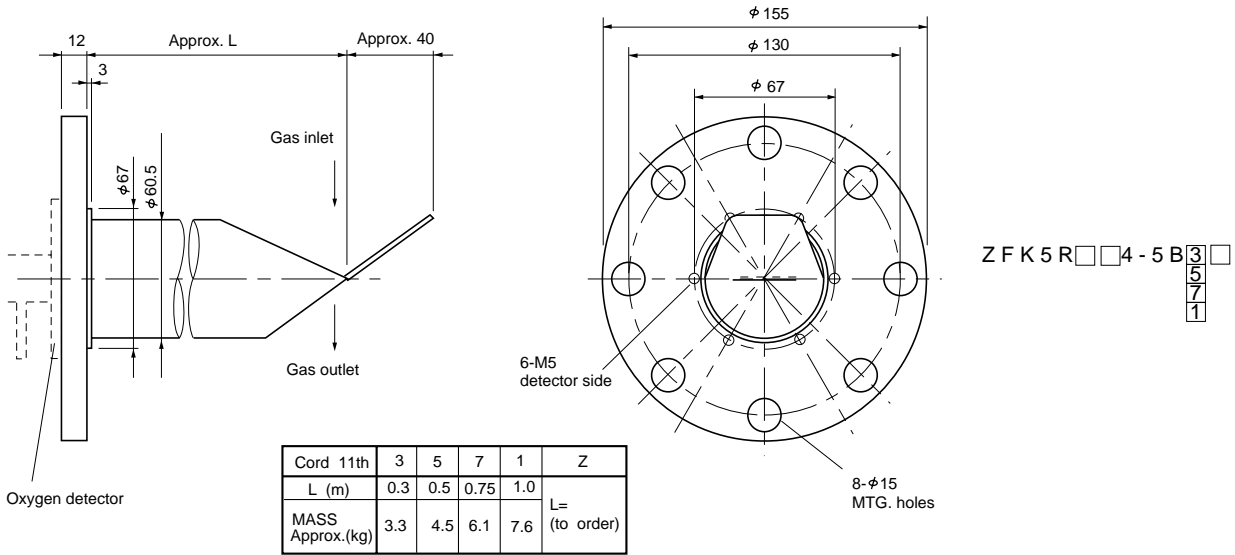

Flow guide tube (with blow - down nozzle)

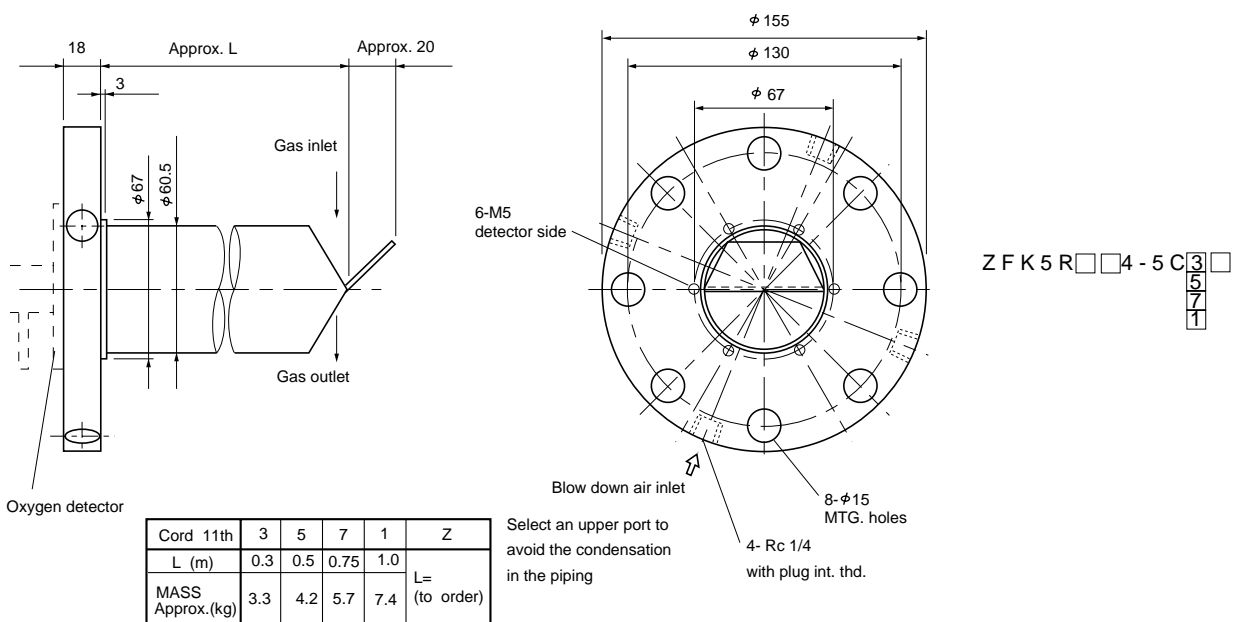

Flow guide tube (for high particulate)

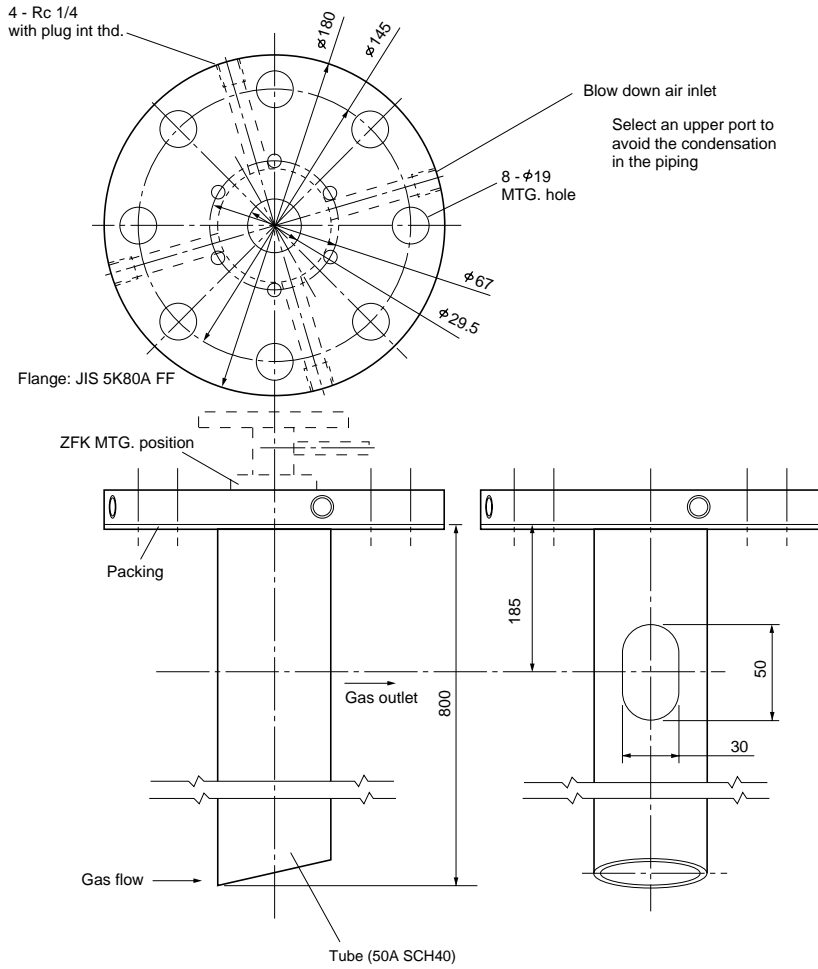

Z F K 5 R □ □ 4 - 6 D $\begin{matrix} 3 \\ 5 \\ 7 \\ 1 \end{matrix}$ □

Cord 11th	3	5	7	1	Z
L (m)	0.3	0.5	0.75	1.0	L= (to order)
MASS Approx.(kg)	4.5	5.6	7.0	8.3	

Flow guide tube (for high particulate with cover)

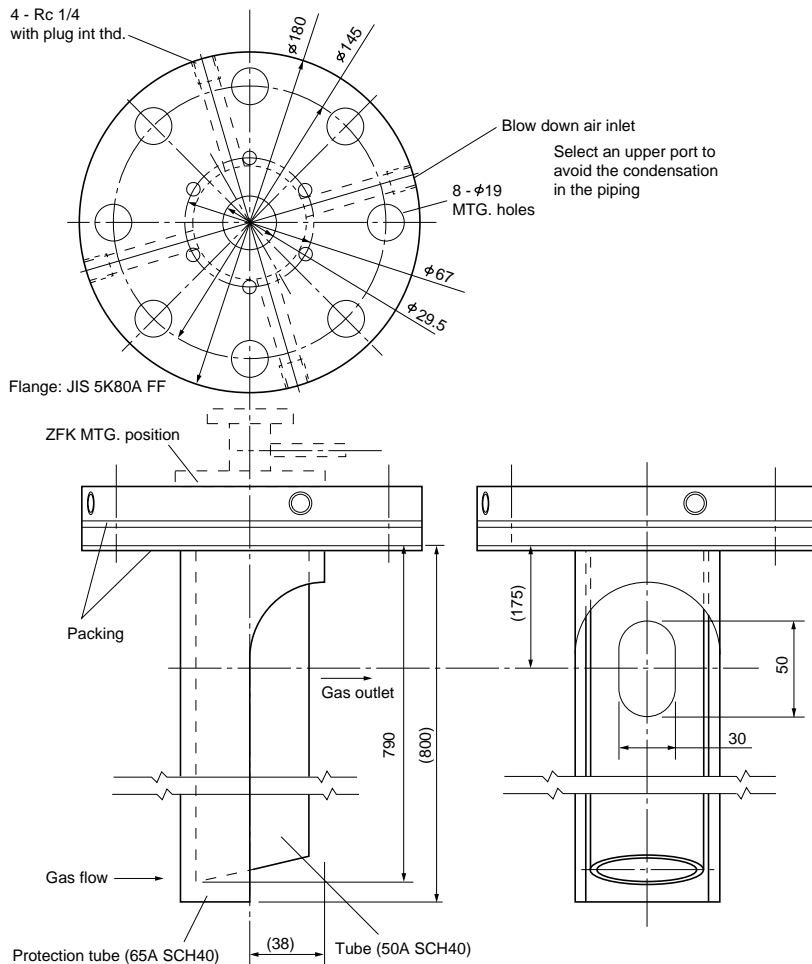

Z F K 5 R □ □ 4 - 6 E $\begin{matrix} 3 \\ 5 \\ 7 \\ 1 \end{matrix}$ □

Cord 11th	3	5	7	1	Z
L (m)	0.3	0.5	0.75	1.0	L= (to order)
MASS Approx.(kg)	7.1	9.0	11.4	13.6	

Converter (ZRM)

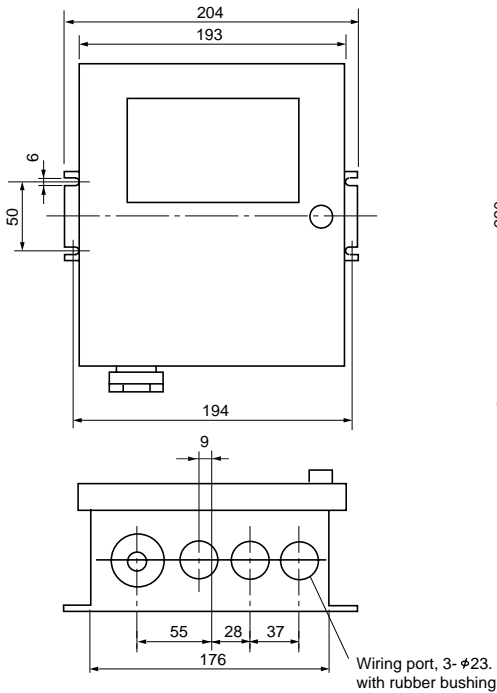

Panel flush mounting

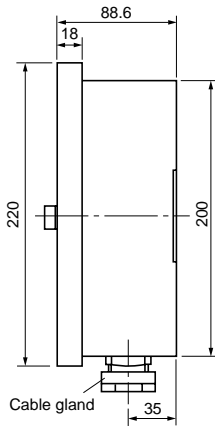

Pipe mounting

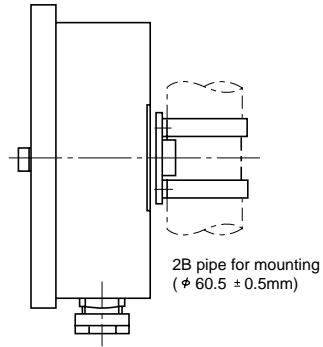

EXTERNAL CONNECTION DIAGRAM

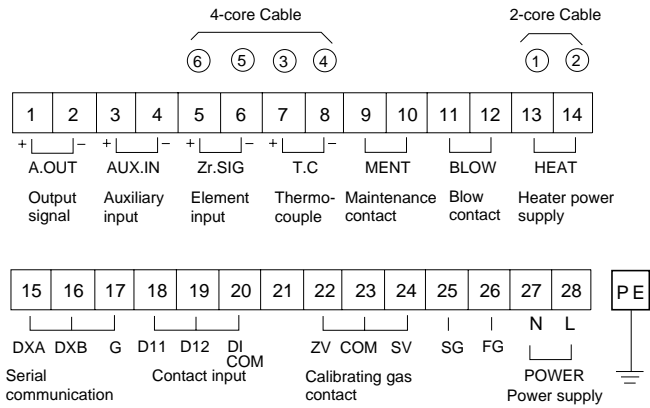

Note (1) : The numbers ① through ⑥ denote detector terminal No. for exclusive - special cables.
 (2) : M3 terminal screws are used for the terminal block.

Ejector (ZTA)

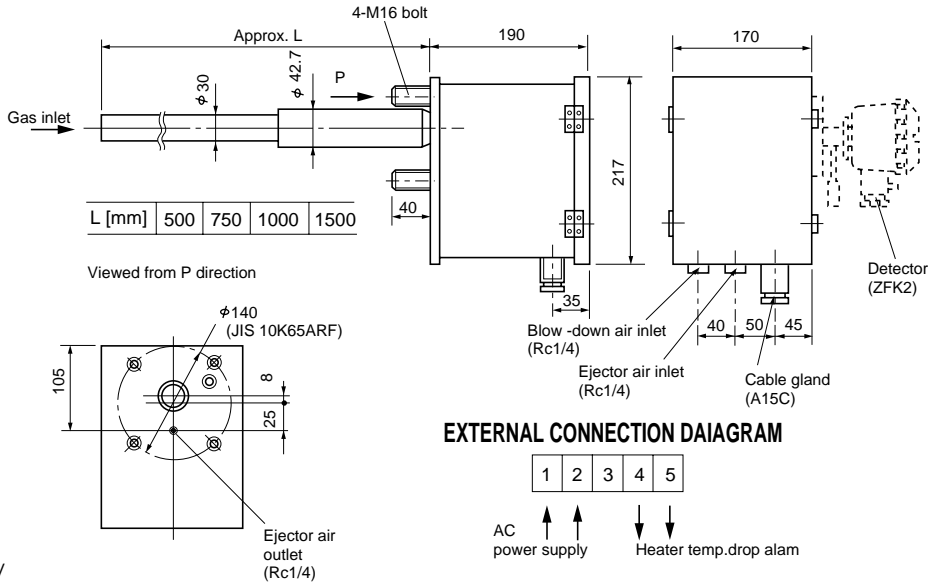

⚠ Caution on Safety

*Before using this product, be sure to read its instruction manual in advance.

Fuji Electric Systems Co.,Ltd.

Head Office

6-17, Sanbancho, Chiyoda-ku, Tokyo 102-0075, Japan
<http://www.fesys.co.jp/eng>

Sales Div.

International Sales Dept.

No.1, Fuji-machi, Hino-city, Tokyo, 191-8502 Japan
 Phone: 81-42-585-6201, 6202 Fax: 81-42-585-6187
<http://www.fic-net.jp/eng>