

KA336-5.0/KA336B-5.0

Programmable Shunt Regulator

Features

- Low temperature coefficient
- Adjustable 4V to 6V
- Wide operating range current of 400mA to 10mA
- Three lead transistor package (TO-92)
- 0.6 ohm dynamic impedance
- ±1.0% initial tolerance available
- Guaranteed temperature stability
- Easily trimmed for minimum temperature drift
- Fast turn on

Description

The KA336-5.0/KA336B-5.0 integrated circuits are precision 5.0V shunt regulators. The monolithic IC voltage reference operates as a low temperature coefficient 5.0V zener with 0.6ohm dynamic impedance. A third terminal on the KA336-5.0/KA336B-5.0 allow the reference voltage and temperature coefficient to be trimmed easily. The KA336-5.0/KA336B-5.0 are useful as a precision 5.0V low voltage references it convenient in obtaining a stable reference from low voltage supplies. Further, since the KA336-5.0/KA336B-5.0 operate as shunt regulators, they can be used as either a positive or negative voltage reference.

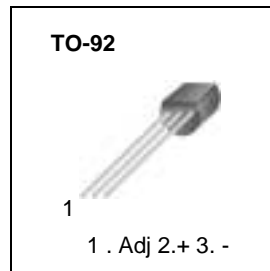

Internal Block Diagram

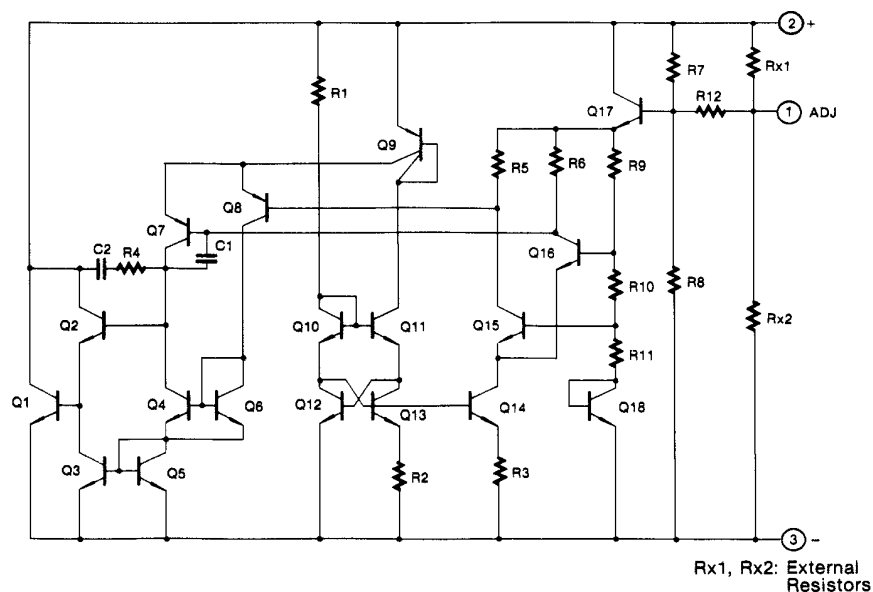

Absolute Maximum Ratings

Parameter	Symbol	Value	Unit
Reverse Current	I_R	15	mA
Forward current	I_F	10	mA
Operating Temperature Range KA336-5.0/KA336B-5.0	T_{OPR}	0 ~ +70	°C
Storage Temperature Range	T_{STG}	-60 ~ +150	°C

Electrical Characteristics

(0°C ≤ T_A ≤ +70°C unless otherwise specified)

Parameter	Symbol	Conditions	KA336-5.0			KA336B-5.0			Unit
			Min.	Typ.	Max.	Min	Typ.	Max.	
Reverse Breakdown Voltage	V_R	T _A = 25°C, I _R = 1mA	4.8	5.0	5.2	4.9	5.0	5.1	V
Reverse Breakdown Change with Current	$\Delta V_R/\Delta I_R$	T _A = 25°C 600μA ≤ I _R ≤ 10mA	-	6	20	-	6	20	mV
Reverse Dynamic Impedance	Z_D	T _A = 25°C, I _R = 1mA	-	0.6	2	-	0.6	2	Ω
Temperature Stability	ST_T	I _R = 1mA	-	4	12	-	4	12	mV
Reverse Breakdown Change with Current	$\Delta V_R/\Delta I_R$	600μA ≤ I _R ≤ 10mA	-	6	24	-	6	24	mV
Reverse Dynamic Impedance	Z_D	I _R = 1mA	-	0.8	2.5	-	0.8	2.5	Ω
Long Term Stability In Reference Voltage	ST	I _R = 1mA	-	20	-	-	20	-	ppm/Khr

Typical Performance Characteristics

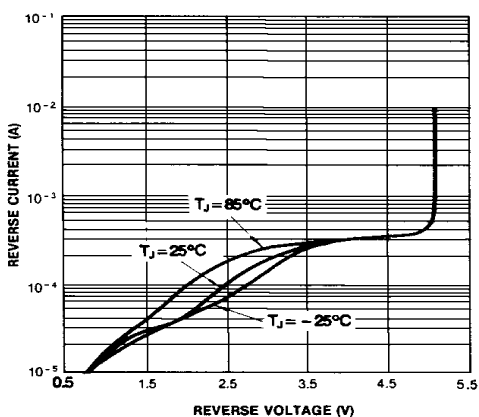

Figure 1. Reverse Characteristics

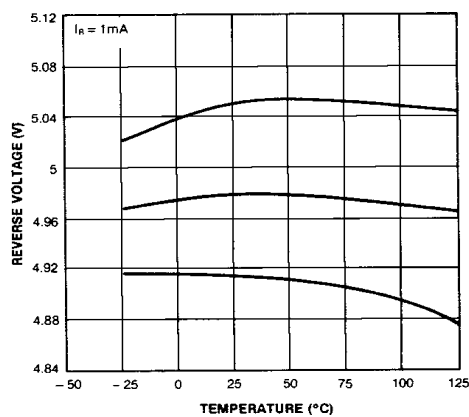

Figure 2. Temperature Drift

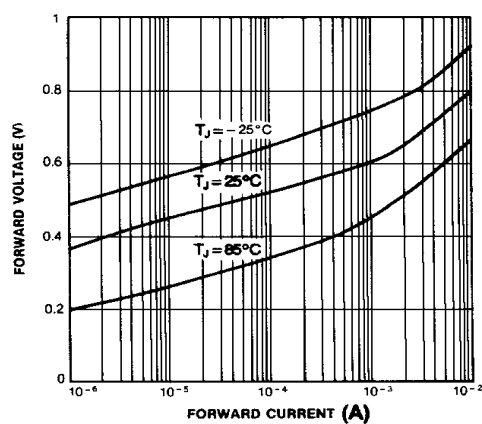

Figure 3. Forward Characteristics

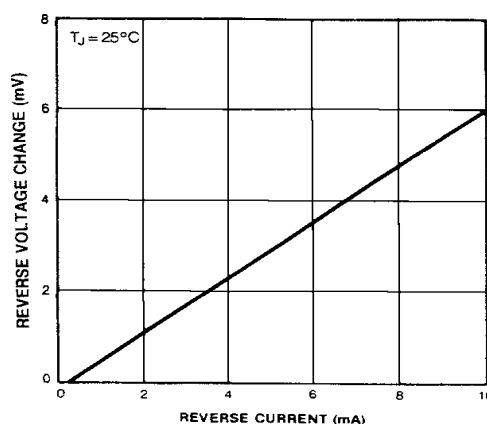
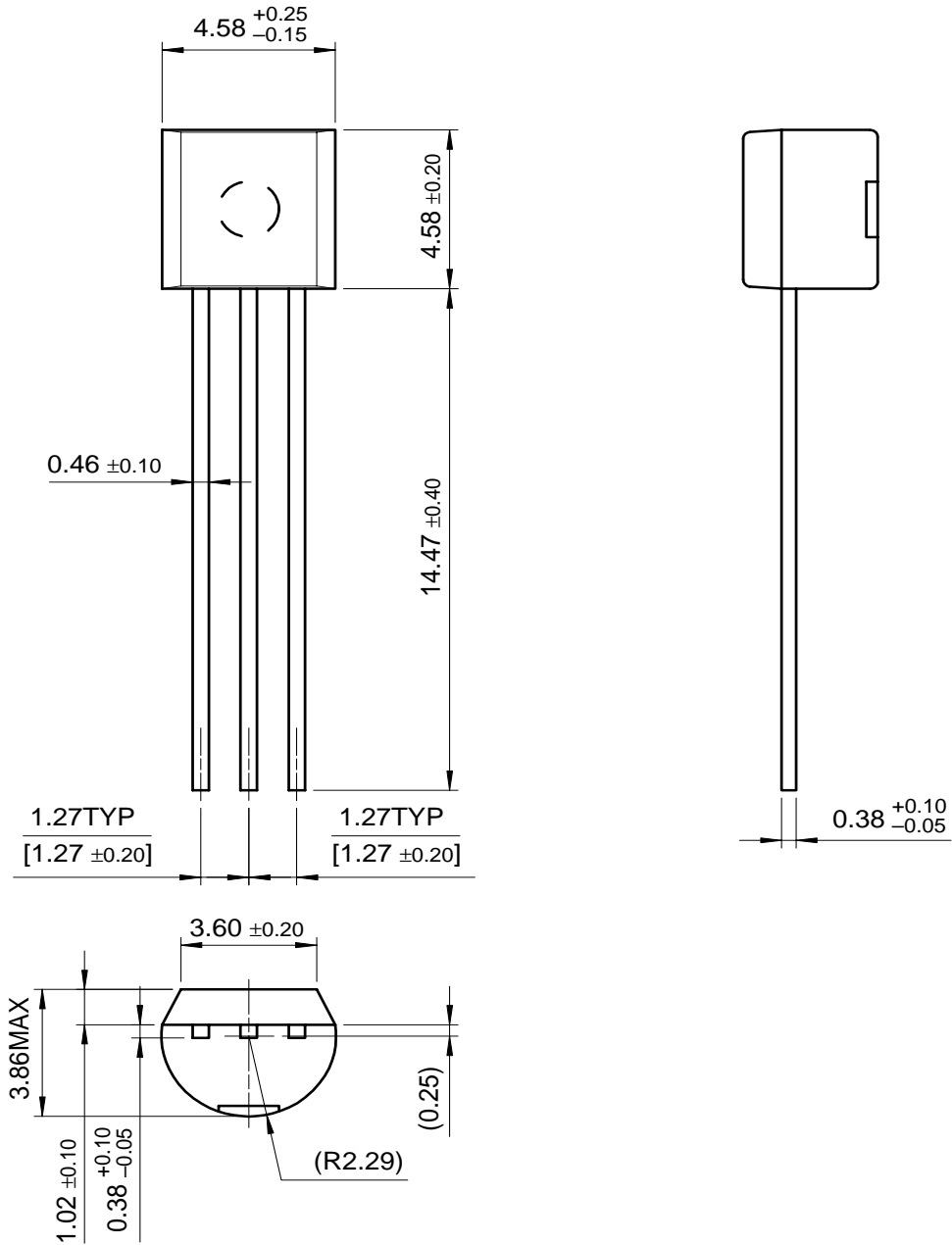

Figure 4. Reverse Voltage Change

Mechanical Dimensions

Package

TO-92



Ordering Information

Product Number	Package	Operating Temperature
KA336Z-5.0	TO-92	0~+70°C
KA336BZ-5.0		

DISCLAIMER

FAIRCHILD SEMICONDUCTOR RESERVES THE RIGHT TO MAKE CHANGES WITHOUT FURTHER NOTICE TO ANY PRODUCTS HEREIN TO IMPROVE RELIABILITY, FUNCTION OR DESIGN. FAIRCHILD DOES NOT ASSUME ANY LIABILITY ARISING OUT OF THE APPLICATION OR USE OF ANY PRODUCT OR CIRCUIT DESCRIBED HEREIN; NEITHER DOES IT CONVEY ANY LICENSE UNDER ITS PATENT RIGHTS, NOR THE RIGHTS OF OTHERS.

LIFE SUPPORT POLICY

FAIRCHILD'S PRODUCTS ARE NOT AUTHORIZED FOR USE AS CRITICAL COMPONENTS IN LIFE SUPPORT DEVICES OR SYSTEMS WITHOUT THE EXPRESS WRITTEN APPROVAL OF THE PRESIDENT OF FAIRCHILD SEMICONDUCTOR CORPORATION. As used herein:

1. Life support devices or systems are devices or systems which, (a) are intended for surgical implant into the body, or (b) support or sustain life, and (c) whose failure to perform when properly used in accordance with instructions for use provided in the labeling, can be reasonably expected to result in a significant injury of the user.
2. A critical component in any component of a life support device or system whose failure to perform can be reasonably expected to cause the failure of the life support device or system, or to affect its safety or effectiveness.