

THX202H

【Switching Power Controller IC】

Contents

Introduction, characteristics and application field	3
Reference frame of interior circuit.....	4
Description of pins' function	4
Ultimate parameters	5
Recommended working condition	5
Electric parameters	5
Principal Discription.....	7
Definition of Electric Parameters	8
Application information	9
Typical application circuit	11
Components Listing	12
Making coils for transformer	13
Test data	14
Wave-form of main experimental units	15
Parameters of thermal resistance and junction temperature.....	19
Dimensional chart of encapsulation.....	20

Introduction

PWM controller of high-performance current mode is specially designed for AC/DC transformer with high performance and price ratio, which supplies continuous output power of 5W within the range of wide-voltage between 85V and 265V, the output power of peak value can be up to 18W. The combination of optimized reasonable circuit design and bipolar faature technology with high performance and price ratio economizes the whole cost ultimately. The power controller can be applied to the typical flyback circuit topology so as to form a simple AC/DC transformer. The startup circuit inside IC is designed as a particular current inhalation way, so it can start up with the magnification function of the power switch tube itself, which lessens the power consumption for starting the resistance remarkably; when the output power is lower, IC will reduce the working frequency automatically, therefore, the standby power consumption becomes extremely low. When the power tube is closed, the interior circuit will bias it reversely, utilize the characteristic of high pressure resistance CB of bipolar transistor directly, and improve its pressure resistance capacity to the high voltage of 700V, which ensures the security of the power tube.

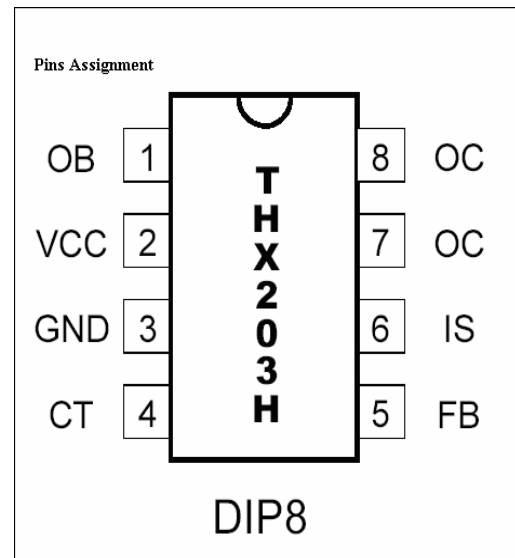

Meanwhile, the perfect function of overload and saturation prevention is provided inside of IC, which can keep away some abnormal status, such as overload, saturation of transformer, and output short circuit, so as to improve the reliability of the power supply. Besides, there is a 2.5V voltage reference integrated inside IC for providing precise voltage to the clock circuit, and clock frequency can be set up by an exterior timing capacity.

Now the standard encapsulation and the environmental protection leadless encapsulation that meets European standard of DIP8 are supplied.

Characteristics

- Set-in high-voltage power switch tube of 700V and few peripheral components
- With the modulation of lock pulse width, the testing is according to the pulse limit current.
- With the function of output frequency reduction, the non-output power consumption can be less than 25W.
- Inner-built ramp and anti-feedback compensation function
- The independent upper-limit current testing controller deals with over-current and over-load of the controller real-timely.
- The period emission pole is turned off and it outputs by deflected voltage, and the pressure resistance of the power tube is improved.
- Set-in current limit resistance with temperature compensation, which makes the current limit precise
- Set-in heat protection circuit
- Startup is accomplished with the magnification function of the switch power tube, and the power consumption of startup resistance is reduced more than 10 times.
- Few peripheral components
- Low startup and operating current
- VCC over-voltage automatic limit
- Wide-voltage output power reaches 5W, and the narrow-voltage output power reaches 8W.

Applied Field

- Adaptor (for example, travel charger, out power station)
- As internal power source of environmental-protection and energy-saving type of household appliances (such as electromagnetic oven and microwave oven)

Reference Frame of Interior Circuit

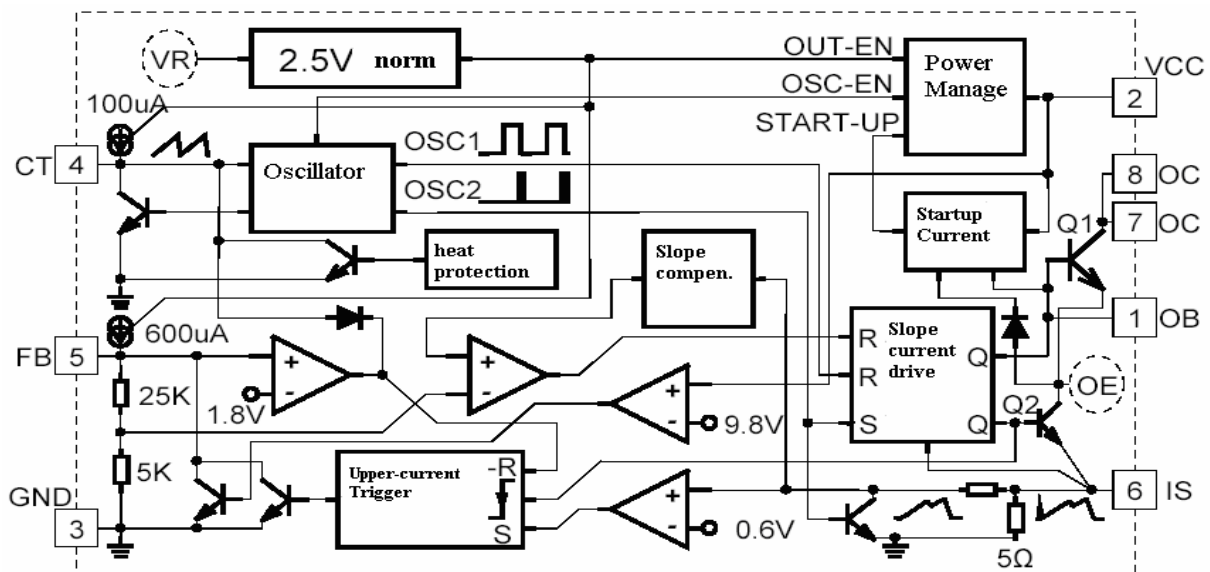

Figure 1. Frame of Interior Current

Description of Pins' function

Pins	Symbol	Pins Description
1	OB	base electrode of power tube, control terminal of start-up current, external startup resistance
2	CT	oscillate capacitance pins, external timing capacitance
3	GND	meet grounding pins
4	FB	feedback pins
5	VCC	supply electric pins
6	NC	OE pins to be hanged in application
7,8	OC	output pins, meet switching transformer

*: During PCB layout, Pin6 should be treated with hanging method and the security distance should be kept more than 1mm between Pin6 and Pin7, so as to avoid discharging.

Limit parameter

Power supply voltage VCC	16V
Startup input voltage	16V
Pins input voltage	VCC+0.3V
Endurance voltage of OC collector	-0.3-700V
Switching current of peak value	300mA
Total dissipation power	1000mW
Operating temperature range	0---+125°C
Deposit temperature range	-55---+150°C
Welding temperature	+260°C,10S

Recommended working condition

Item	Minimum	Typical	Maximum	Unit
Power supply voltage, VCC	4.8	5.5	9.0	V
Pins input voltage	-0.3	-	Vcc	V
Reverse voltage of peak value	-	-	500	V
Switching current of peak value	-	-	250	MA
Timing capacitance	270	330	680	PF
Oscillating frequency	32	61	81	KHz
Operating temperature	0		70	°C

Electric Parameter ($T_a=25^{\circ}\text{C}$, $V_{cc}=5.5-7.5\text{V}$, $C_t=330\text{PF}$)**Output**

Item	Testing condition	Minimum	Typical	Maximum	Unit
Maximum pressure resistance of switching tube	$I_{oc}=10\text{mA}$	700	-	-	V
on-saturation pressure drop	$I_{oc}=250\text{mA}$	-	-	1	V
Output rise-time	$C_L=1\text{nF}$	-	-	75	ns
Output fall-time	$C_L=1\text{nF}$	-	-	75	ns
Output limit current	$T_j=0-100^{\circ}\text{C}$	250	270	290	mA
OE clamp voltage	$O_E=0.001-0.29\text{A}$	-	1.5	-	V

Reference

Item	Testing condition	Minimum	Typical	Maximum	Unit
Reference output voltage	$I_o=1.0\text{mA}$	2.4	2.5	2.6	V
power adjustment ratio	$V_{cc}=5.5-9\text{V}$	-	2	20	mV
Load adjustment ratio	$I_o=0.1-1.2\text{mA}$	-	-	3	%
Temperature stability		-	0.2	-	mV/ $^{\circ}\text{C}$
Output noise voltage	$F=10\text{Hz}-10\text{KHz}$	-	-	50	μV
Long-term stability	Operate 1000h under the condition of $T=85^{\circ}\text{C}$	-	5	-	mV

Oscillator

Item	Testing condition	Minimum	Typical	Maximum	Unit
Oscillating frequency	$C_t=330\text{PF}$	59	66	73	KHz
Frequency change ratio with voltage	$V_{cc}=5.5-9\text{V}$	-	-	1	%
Frequency change rate with temperature	$T_a=0-85^{\circ}\text{C}$	-	-	1	%
Vibration amplitude of oscillator(V_{p-p})		-	2.2	-	V
Drop edge of oscillator	$C_t=330\text{PF}$	-	800	-	ns

Feedback

Item	Testing condition	Minimum	Typical	Maximum	Unit
Input impedance	Pull-up current	-	0.50	0.60	mA
	pull-down resistance	-	30	-	$\text{K}\Omega$
Power supply rejection ratio	$V_{cc}=5.5-9\text{V}$	-	60	70	dB

Current sampling

Item	Testing condition	Minimum	Typical	Maximum	Unit
Current sampling limit		0.55	0.60	0.65	V
upper limit current prevention		0.25	0.27	0.29	A
Power supply rejection ratio		-	60	70	dB
transmission delay		-	150	250	ns

Modulation of pulse width

Item	Testing condition	Minimum	Typical	Maximum	Unit
Maximum duty cycle		53	57	61	%
Minimum duty cycle		-	-	3.5	%

Power current

Item	Testing condition	Minimum	Typical	Maximum	Unit
Startup acceptance current		1.6	2.4	2.3	mA
Startup static current		-	55	80	μ A
Static current	V _{cc} =8V	-	2.8	-	mA
Startup voltage		8.6	8.8	9.0	V
Close voltage of oscillator		4.0	4.2	4.5	V
Restart voltage		-	3.6	-	V
Over-voltage limit margin		9.5	10	10.5	V

Description of the Principle

- During start-up phase, VR is closed when electrified; FB pull-up power source is closed, the start-up current is input from power tube to VCC through OE; OB controls the base current of power tube and limits the current of power tube collector (namely, THX202H starts the acceptance current), accordingly, the security of the power tube is ensured; when VCC voltage goes up to 8.8V, the start-up phase is ended, and it comes into the normal phase.
- During normal phase, VCC voltage shall keep at 4.8~9.0V, VR outputs 2.5V benchmark; FB pull-up current source starts up; the oscillator output OSC1 decides the maximum duty cycle, output OSC2 tries to touch off the power supply to enter open cycle to enter the open cycle, and shield flashing peak current of the power tube; if FB is less than 1.8V (about between 1.2-1.8V), the cycle of the oscillator will increase with it, the less FB is, the wider the cycle of the oscillator is, until the oscillation stops (This characteristic reduces the standby power consumption of the switching power.) ; if the peripheral feedback tries to make VCC more than 10V, the in-circuit is fed back to FB and makes VCC stabilize the voltage at 9.8V (According to this characteristic, we can may not adopt peripheral feedback circuit, and stabilize the output voltage by in-circuit, but the precision of stabilizing voltage is low); During the open cycle, OB supplies base current

for the power tube, OE pulls down the emitter of the power tube to IS, and OB adopts the driving parameter of ramp current (it refers to that OB on-current is the parameter of IS, when IS is 0V, OB on-current is about 24mA, then OB on-current increases linearly with IS, when IS increases to 0.6V, OB on-current is about 24mA, this characteristic makes effective use of the output current of OB, decreases the power consumption of THX202H), if IS detects that the specified current FB, it will come into the close cycle; during the close cycle, OB pulls down, the power tube will not shut off immediately, but OE clamps 1.5V (after the power tube is shut off, the base will be biased reversely, which improves the voltage endurance); during open or close cycle, if the power tube is detected beyond the upper limit current, the trigger of the upper limit current will be placed preferentially and forces FB to drop, the duty cycle will become less so as to protect the power tube and transformer; at the beginning of next close cycle or when FB is less than 1.8V, the trigger of the upper limit current will reset. In addition, THX202H is installed over heat protection internally, when the internal temperature is higher than 125°C, it will broaden the cycle of the oscillator and makes the temperature of THX202H less than 135°C; The ramp compensation is also placed internally, when THX202H is in a big duty cycle or in the mode of constant current, it can stabilize the open/close cycle.

- If VCC declines to 4.2V or so, the oscillator will shut off, OSC1 and OSC2 are in the low level, and the power supply keeps at close cycle; when VCC goes on declining to 3.6V or so, THX201 will come into the start-up phase once again.

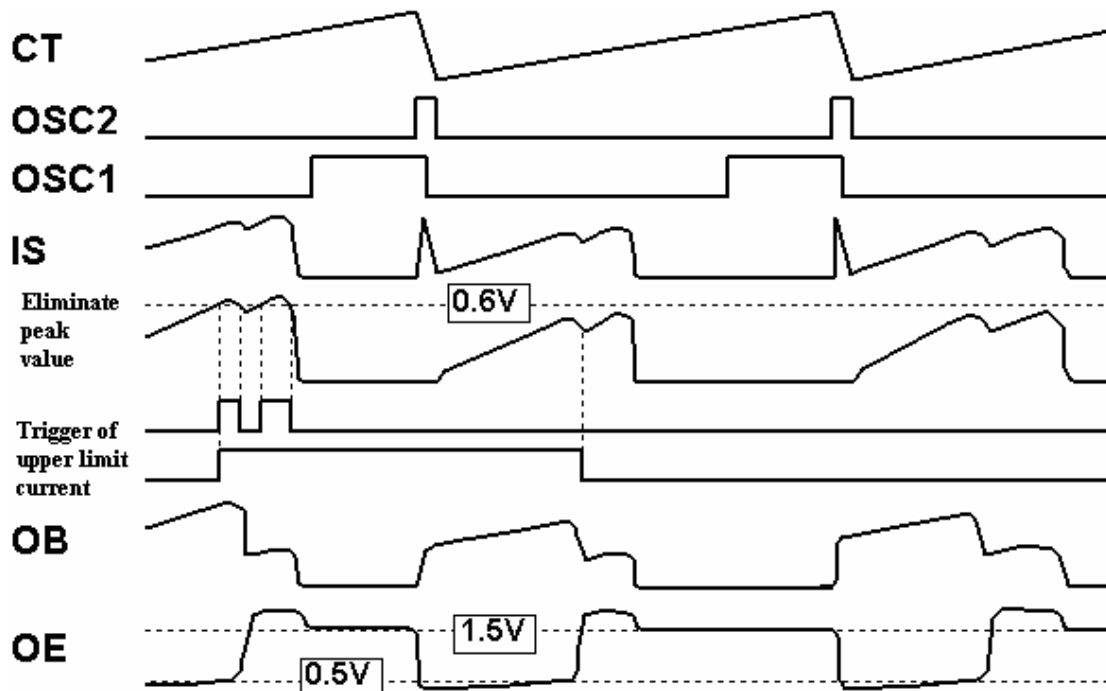

Fig.2 Waveform Graph of Open and Close Cycle at Normal Phase

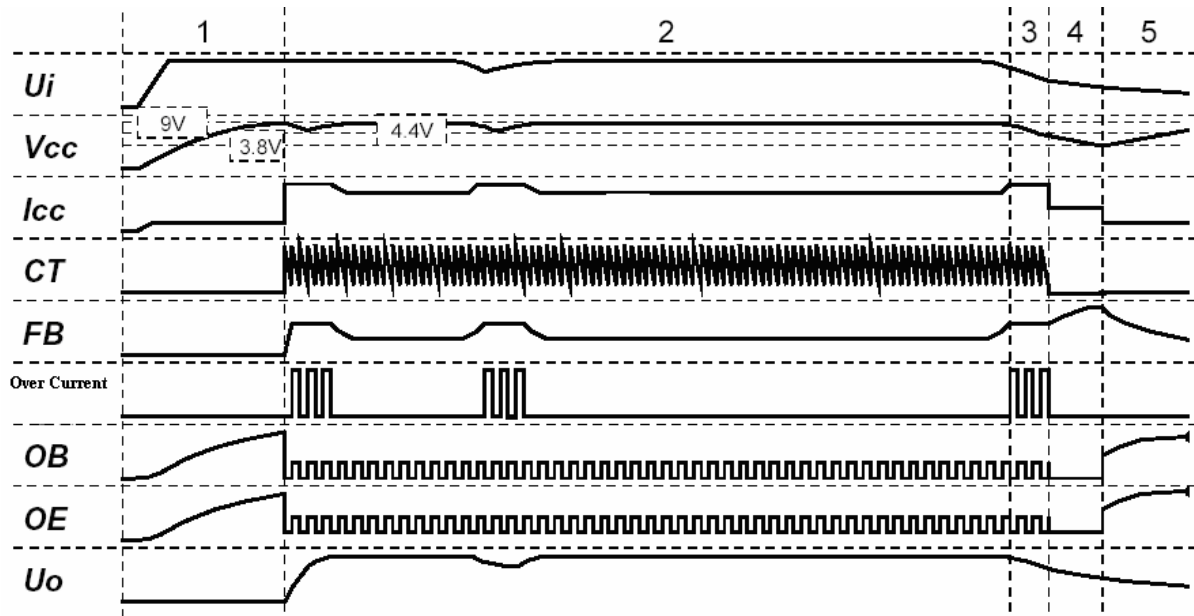

Fig.3 Overall Waveform Graph of THX202H

Definition of Electric Parameter

- Start-up acceptance current: the current on OC when OB inputs 0.5mA during the start-up phase
- Start-up Quiescent Current: the current of minimum current source that can make VCC oscillate (namely finish the start-up of THX202H) when VCC meets filter capacitance and adjustable current source, CT meets 330PF, and other pins hang in the air.
- Start-up Voltage: Maximum VCC value of above VCC oscillation.
- Re-start Voltage: Minimum VCC value of above VCC oscillation.
- Close Voltage of Oscillator: VCC value that makes RC oscillator stop oscillating when the above VCC oscillates the falling edge.
- Quiescent Current: VCC power current when FB is grounded with 1.0K of resistance at normal phase.
- Pull-up/pull-down Current of the Oscillator: at normal phase, FB is 2.5V, CT is 1.25V, and CT is in pull-up/pull-down current.
- FB Pull-up Current: Pull-up current on FB at normal phase when FB is 2.5V, IS is 0V.
- FB Upper Limit Current Prevention: The pull-down current on FB at normal phase when FB is 6V, IS is 0.3V.
- Internal Feedback Power Voltage: VCC value of THX202H power supply of the circuit without peripheral standby at normal phase
- OC Upper Limit Voltage: the minimum OC current of pull-down current on FB when FB is 6V
- Ramp current drive: it refers to the power tube base drive OB on-current is the function of IS, when IS is 0V, on-current OB is about 24mA, then on-current OB will increase linearly with IS, when IS is increased to 0.6V, on-current OE is about 40mA.

Application Information:

1. Relationship between CT timing capacitance and switching frequency

CT capacitance is charged by 50uA constant current through internal current source to for the rise-up edge, when the voltage is charged to 1.6V, the internal circuit will discharge CT with 1.9mA of pull-down current to form the fall-down edge of the clock, and accomplish a clock cycle, which is about:

$$T=CT*48000 (S)$$

$$Fs=1/T (Hz)$$

Although the bipolar circuit can work under higher frequency, but for the switch of bipolar power, the influence caused by switch loss for the storage time is still be considered. Generally, the appropriate switching frequency is about below 70KHz. Under common application situation, CT capacitance of THX202H can be configured by 330PF, when the relevant working frequency is around 66KHz.

2. FB feedback and control

In normal working state, the voltage of FB will decide the value of the maximum switching current, the higher the voltage is, the bigger the switching current is (it is only limited at the peak value). FB pins pull up 600uA power source internally, the pull-down resistance is about 23KΩ (it approximates the equivalent value). In addition, when FB voltage is less than 1.8V, the oscillating cycle will be enlarged, the switching frequency will declined, the more it is less than 1.8V, the lower the switching frequency is. The external FB capacitance will influence

the feedback bandwidth, so some external parameters will be affected, such as transient-state characteristic.

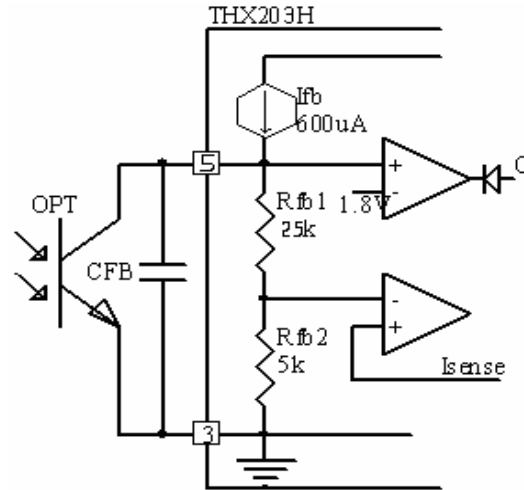

As for the value of CFB capacitance, the typical application can be selected according to the frequency character of feedback circuit between 10nF and 100nF. It is recommended to use 22nF.

3. Over temperature protection

The interior of IC integrates the function of over temperature protection. When the internal temperature of the chip reaches 125 °C , the over-heat protection circuit will work, it will pull down the clock signal, the switching frequency will fall until the oscillator is turned off.

As shown in the following figure,

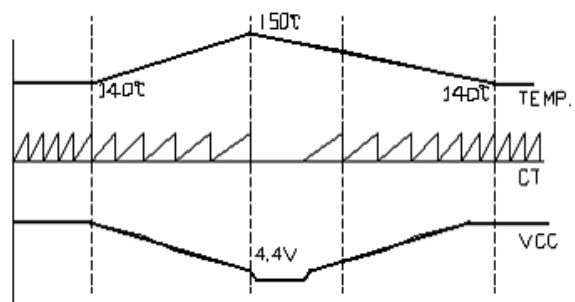

4. Driving characteristic and high voltage endurance bias technology of power tube

The power tube adopts the ramp current drive, the driving current will increase with the output power, when FB is 0, the current of OB is about 24mA, when FB is 6V, the current of OB is about 40mA, and the driving power consumption will decrease remarkably when the output is low.

The interior of IC integrates the particular bias technology, when the power tube is shut, the output of OB will be pulled down to the ground, meanwhile, it will bias the output of OE to 1.5V or so, bias the emitter junction, accelerate the decreasing speed of Ic current, expand the effective safe working area, the switching tube affords the reverse voltage CB, therefore, the endurance characteristic of the switching tube can be up to 700V. For more detail information for the voltage endurance characteristic of the switching tube, please refer to the relevant technical data.

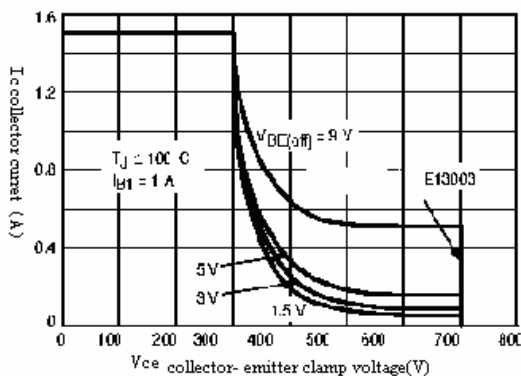

The bias waveform is shown as follows:

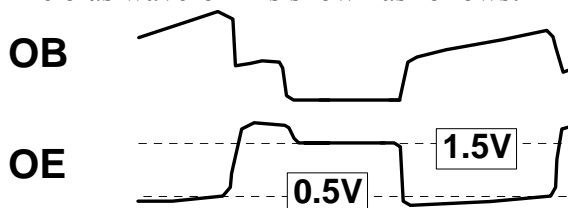

5. Over-voltage and under-voltage protection

IC has the function of slow-moving

under-voltage protection, when the voltage of VCC reaches 8.8V, IC will set out to start, the initial start-up voltage is provided by the driving resistance, the high voltage of input will be injected into the base of the switching tube through Ic current, consequently, the driving voltage is formed. When IC works normally, the voltage of VCC should be keep between 4.8V and 9V (including the situation of full load output), if the voltage of VCC falls to 4.2V, the oscillator will enter the state of shutoff, when it decreases to 3.6V further, IC will begin to reset.

As shown in the following figure:

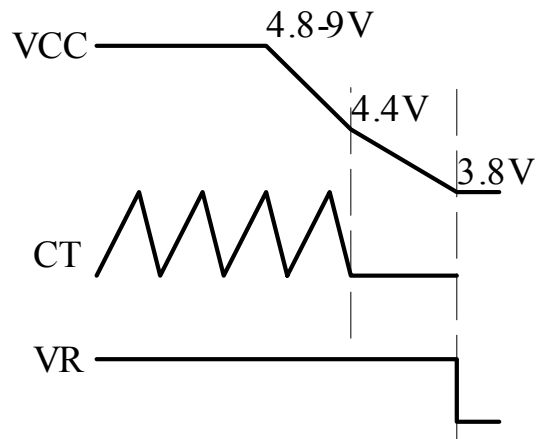

VCC in side IC is provided with a comparator controller of the upper limit voltage, if VCC tries to be more than 10V, the comparator will work, FB will be pulled down, and it will lock VCC to 10V, and reach the limit function of over voltage, by which the voltage feedback function of the front terminal can be accomplished conveniently, the rising phenomenon of the output voltage in large extent can be avoided when the open-loop is output, so as to guarantee the security of the load. Because of the existence of this characteristic, the design of VCC shall be kept at the proper range, so as to avoid VCC rising excessively high when the output is high, and make the output voltage escape from

decreasing when IC over-voltage limit works.

6. Maximum switching current limit

IC has the function of current limit cycle by cycle. It will test every switching current in every switching cycle, if the current fixed by FB or upper limit current prevention is reached, it will come into the close cycle, and the detection of the current has the function of real-time foreland hide, it can shield the switching peak, and avoid the wrong detection of the switching current. Then the reasonable temperature compensation eliminates the influence of temperature, comparing with normal MOSFET (the alteration of R_{on} will be large when the temperature changes) switching chip, the switching current can always be very accurate in a larger range, thus not too much allowance is needed to match a larger working temperature range for the designer when he designs the scenario, and the security of the circuit for use can be improved.

The typical maximum limit value of switching current for THX202H is 0.25A. When designing a flyback power with 80V of emitter voltage, it can accomplish the output power of more than 5W easily, and meet the broad temperature range.

7. Requirement of heat elimination

As for a typical power switch, it must have necessary heat elimination

Typical application circuit(input 85-265V, output 5V 1A):

measures, so as to avoid that the excessive heat leads to heat protection. The primary heat inside IC is produced by the on-off wasting of the switching tube, so appropriate heat elimination position is Pin7-8 pin of IC, one wields way is to pave PCB copper foil of a certain area on Pin7-8 pin, what's more, plating tin on the copper foil will improve the heat elimination ability greatly. For an input of 85-265V, the typical application of 5W output and 100mm² copper foil are necessary.

Reference wiring is as the following figure:

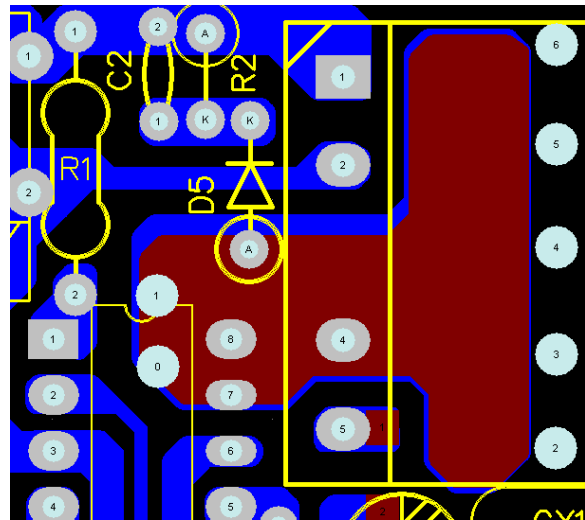

No.	Component Name	Spec./Model	encapsulation	Amount	Sign	
1	Resistance	100R	0805	1	R5	
2		1K	0805	1	R6	
3		4.7K	1206	2	R1	R9
4		10K,1%	0805	1	R7	
5		10.5K,1%	0805	1	R8	
6		75K	1206	1	R4	
7		1M	1206	2	R2	R3
8	Capacitance	331J/50V	0805	1	C4	
9		222/1KV	1206	1	C5	
10		223/50V	0805	1	C3	
11		681J/50V	0805	1	C7	
12		104/50V	0805	1	C8	
13	Capacitance Y	222M/400V	CT7,Y1	1	CY1	
14	ELCC	6.8uF/400V	EC3.5-8	2	C1	C2
15		22uF/16V	EC3-5	1	C6	
16		220uF/16V	EC3-6.3	1	C9	
17		470uF/16V	EC3.5-8	1	C10	
18	Diode	1N4001	DO-35	1	D3	
19		FR107	DO-41	1	D2	
20		SR260	DO-41	1	D4	
21	Rectification bridge	DF06S	DF-S	1	D1	
22	Luminous tube	LED2.5	D2.5	1	D5	
23	Induction of color code	EC-332K	D4*8mm	1	L1	
24	Power inductance	DR6*8,10uH	DR6*8	1	L2	
25	Transformer	EE16	EE16-P10	1	T1	
26	Insurance tube	F1A/250V	D4*10mm	1	RF1	
27	voltage-dependent resistance	7D471K	CT7	1	TZ1	
28	IC	THX202H	DIP8	1	IC1	
29		TL431	TO92	1	IC3	
30		PC817B	DIP4	1	IC2	

31	Circuitry panel	PCB,28x53mm		1		

Coils of the Transformer:

1. Parameters of magnetic core

Core : EF16,TDK PC40 $A_e=19.8mm^2$ $A_w=39.8mm^2$

Bobbin : EF16, 10PIN, 4+6PIN,VELOX 420-SEO , 94V0

$L_p=3.1mH\pm 10\%$

2. Bobbin diagram

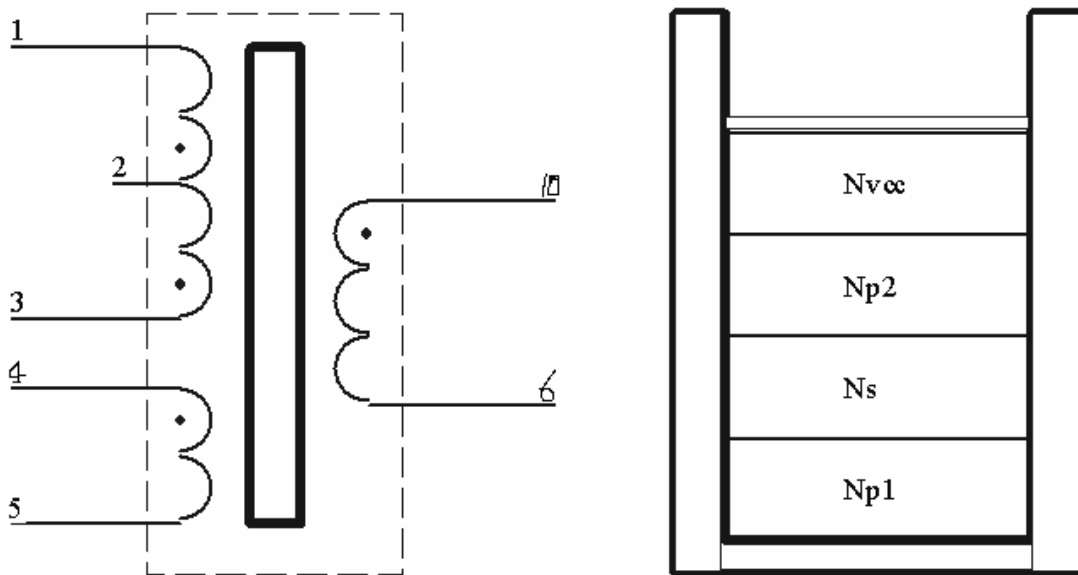

3. Bobbin data

No.	Name	Spec.	Direction	coil/layer	Note
1	Np1, 1 st segment of main coil	F0.2mm*1P,2UEW	2-1	80TS	Thick coiling
2	insulated adhesive paper	3M,No.1350	--	3 tiers	--
3	Ns, output coil	F0.50mm*1P,3UEW	7-8	11TS	Thin coiling
4	insulated adhesive paper	3M,No.1350	--	3 tiers	--
5	Np2, 2nd segment of main coil	F0.2mm*1P,2UEW	3-2	80TS	Thick coiling
6	insulated adhesive paper	3M,No.1350	--	2 tiers	--
7	Nvcc, ICp power supply coil	F0.2mm*1P,2UEW	5-6	13TS	Thin coiling

8	insulated adhesive paper	3M, No.1350	--	3 tiers	--
---	--------------------------	-------------	----	---------	----

Note: the transformer is coiled with copper skin 1.1TS and welded to meet Pin6.

Testing data:

Testing item	Testing data	Unit	Input Voltage (V)					
			85	110	135	180	220	265
Input power (standby power) when $I_o=0A$		W	0.06	0.07	0.08	0.11	0.14	0.21
Output voltage when $I_o=0A$		V	5.13	5.12	5.13	5.13	5.13	5.13
Output ripple when $I_o=0A$		mV	15.4	13.0	12.8	15.4	16.8	16.4
Output voltage when $I_o=1A$		V	5.13	5.12	5.12	5.12	5.12	5.12
Output ripple when $I_o=1A$		mV	15.6	14.0	13.4	13.0	13.4	13.4
Switch power when $I_o=1A$		%	70.5	73.1	73.9	75.2	73.7	73.1
Output voltage when $I_o=0.75A$		V	5.12	5.13	5.12	5.12	5.12	5.12
Output ripple when $I_o=0.75A$		mV	11.8	10.2	11.0	11.0	10.2	10.8
Switch efficiency when $I_o=0.75A$		%	71.2	76.0	73.9	74.7	73.3	72.7
Output voltage when $I_o=0.5A$		V	5.12	5.12	5.12	5.12	5.12	5.12
Output ripple when $I_o=0.5A$		mV	11.6	10.8	11.8	10.8	11.8	11.6
Switch efficiency when $I_o=0.5A$		%	70.5	73.2	74.4	72.9	71.9	70.9
Output voltage when $I_o=0.25A$		V	5.12	5.13	5.12	5.12	5.12	5.12
Output ripple when $I_o=0.25A$		mV	10.6	10.8	11.0	10.6	12.4	11.4
Switch power when $I_o=0.25A$		%	68.5	70.1	70.7	69.6	67.7	65.3
Input power when the output suffers from short circuit		W	0.44	0.71	0.89	1.28	1.63	1.92

Electric load: PROGIGIT 3310D, power meter: GW GPM-8212, Oscillograph: Taike TDS-2014

Primary waveform of testing point:

1. Vce waveform diagram

Vin=85V, Io=0.5A

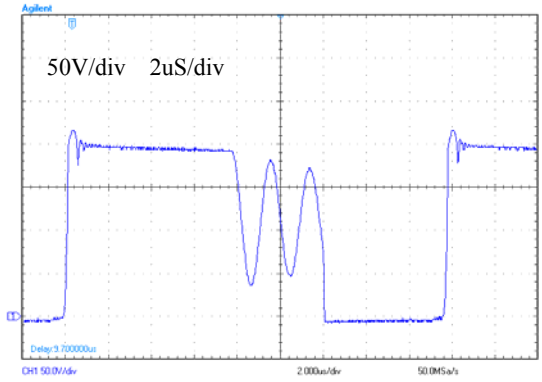

Vin=85V, Io=1A

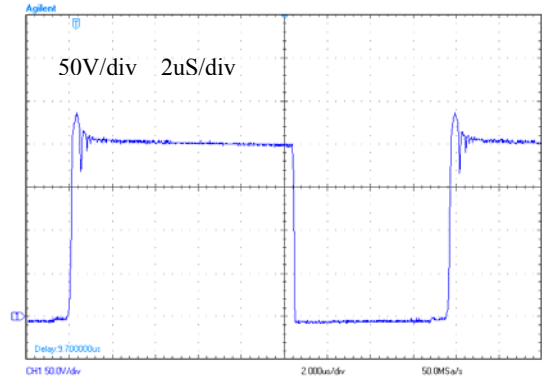

Vin=110V, Io=0.5A

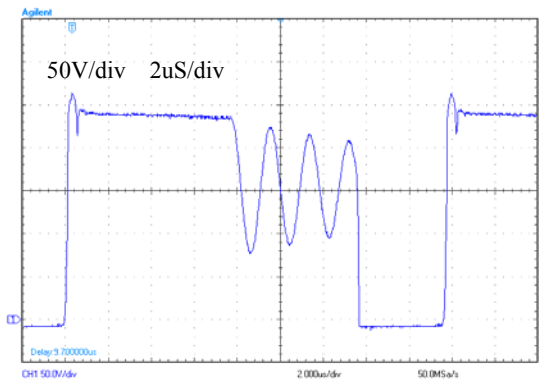

Vin=110V, Io=1A

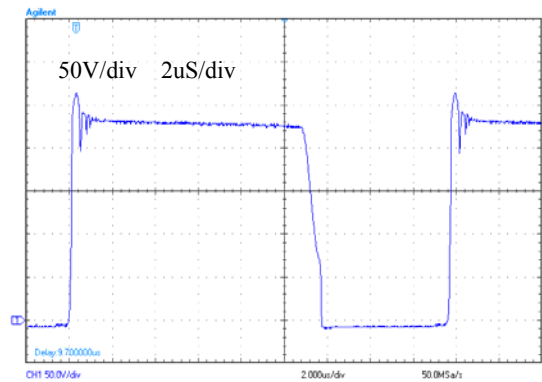

Vin=220V, Io=0.5A

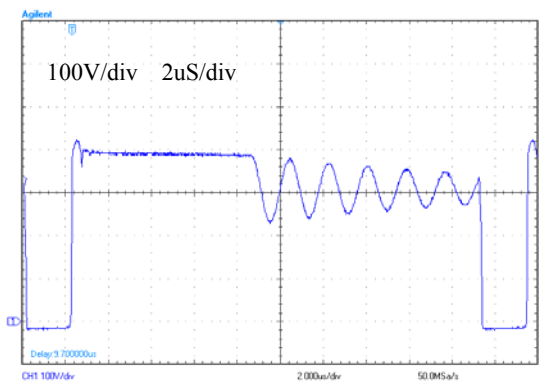

Vin=220V, Io=1A

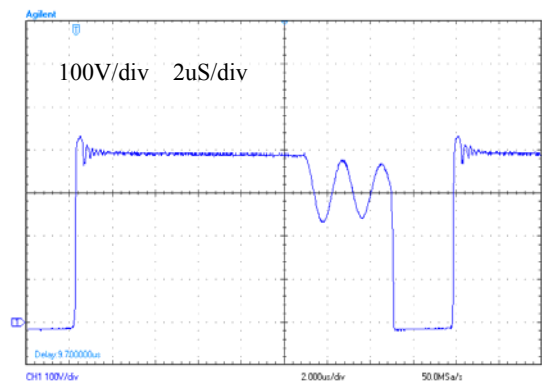

Vin=265V, Io=0.5A

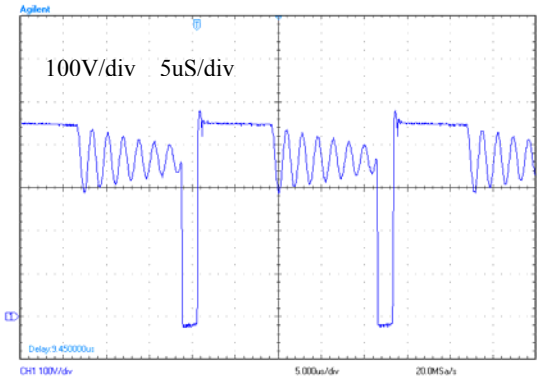

Vin=265V, Io=1A

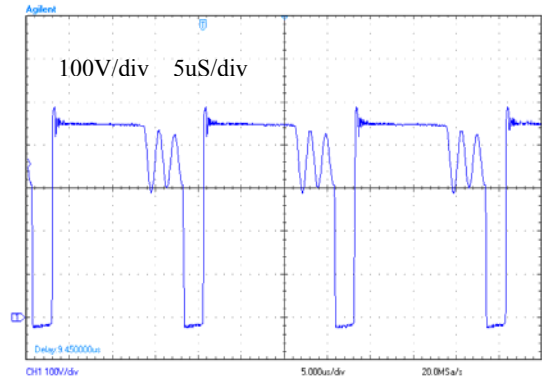

2. Output noise waveform

Vin=85V, Io=1A

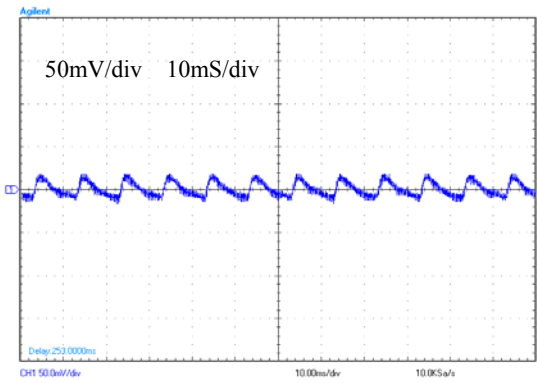

Vin=265V, Io=1A

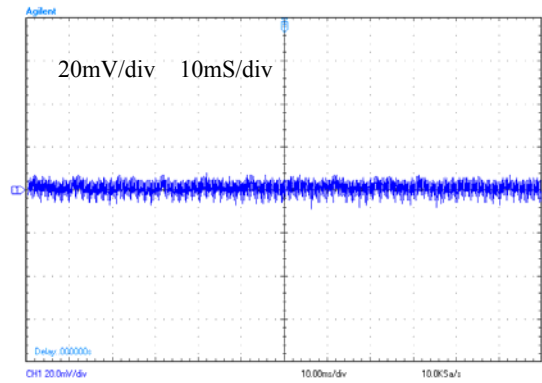

3. Output ripple waveform

Vin=85V, Io=1A

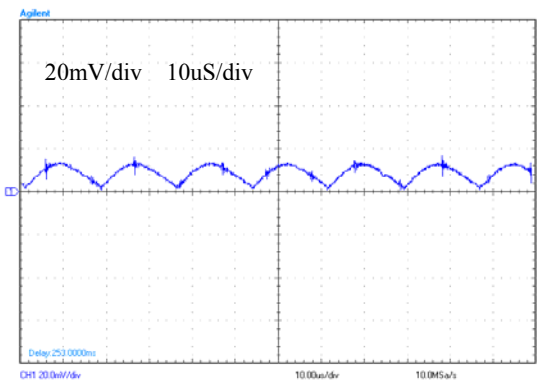

Vin=265V, Io=1A

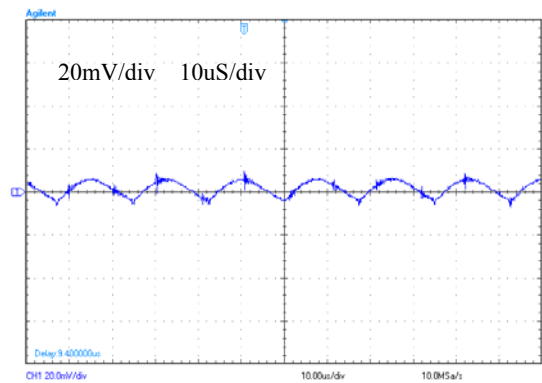

4. Output waveform on start-up

Vin=85V, Io=1A

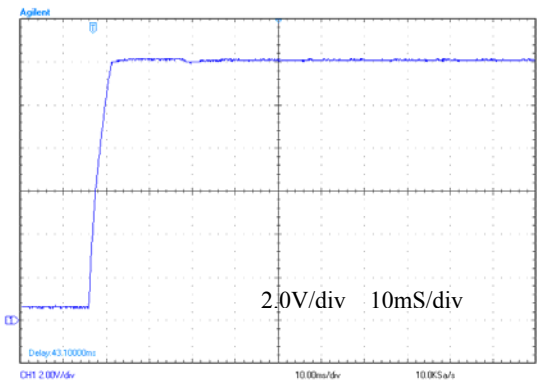

Vin=265V, Io=1A

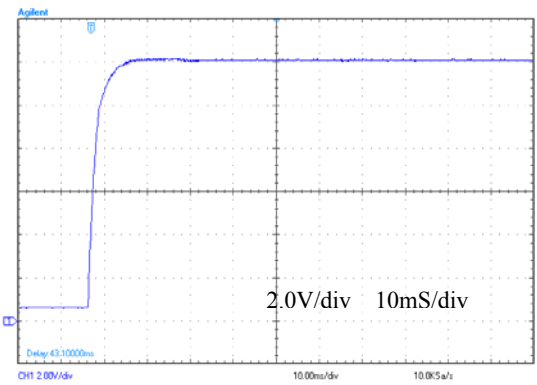

5. Vce and Vo waveform on start-up

Vin=85V, Io=1A

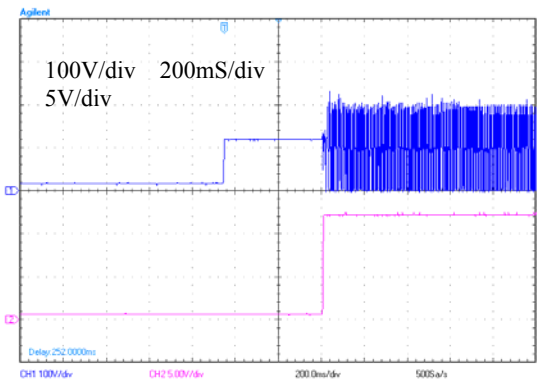

Vin=265V, Io=1A

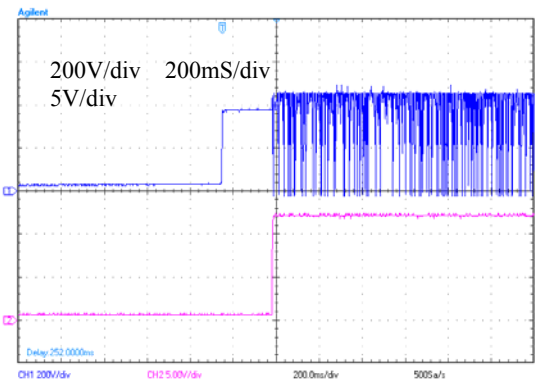

6. Vce waveform when the output suffers short circuit

Vin=85V, Io=Short

Vin=265V, Io=Short

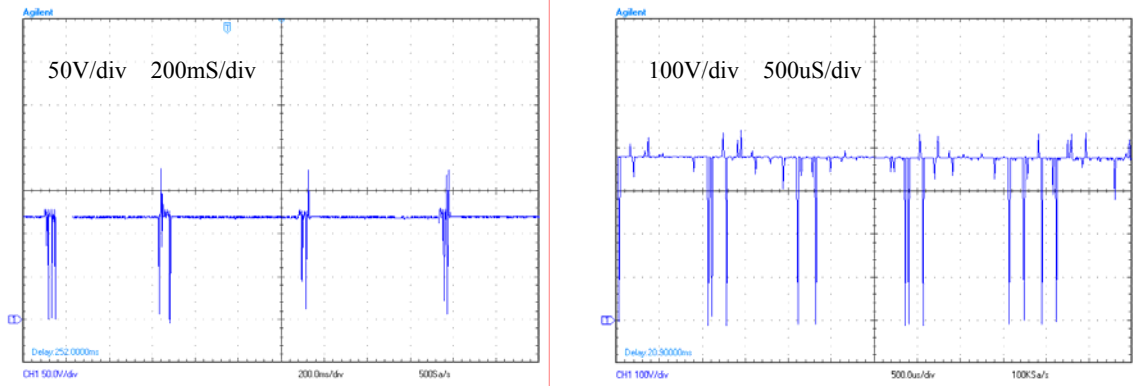

Efficiency curve under various conditions of input and output

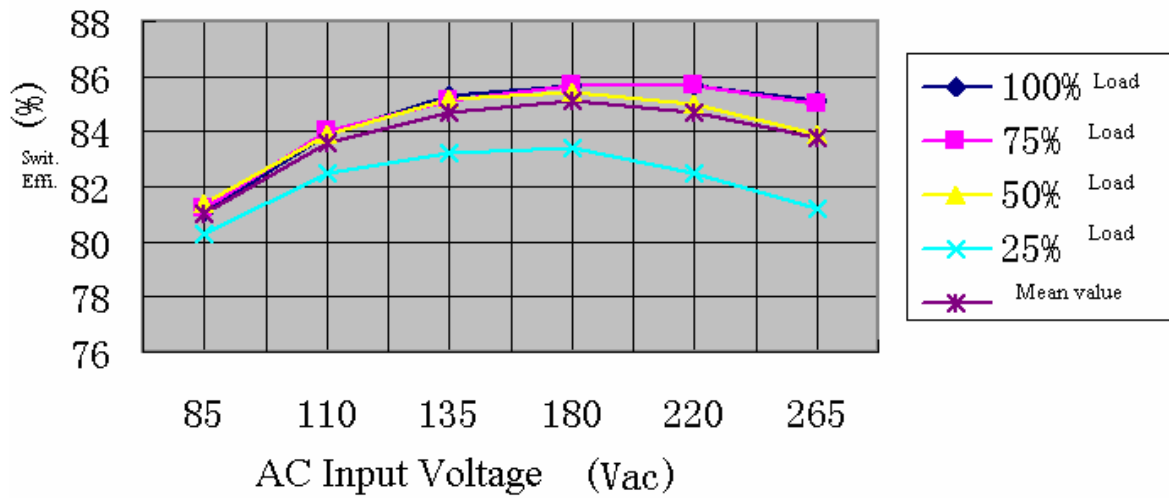

Input power curve during non-load

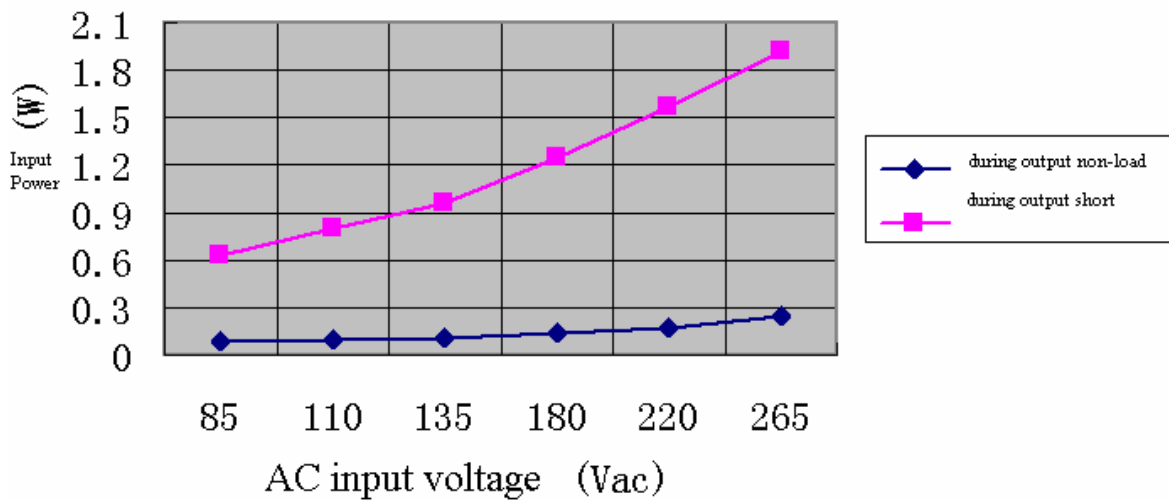

Bland for this page)

IC reference junction temperature and heat resistance	
Data of DIP8 encapsulation junction temperature (reference)	
$(\theta_{JC})^1$	20°C/W
$(\theta_{JA})^2$	70°C/W
Note: 1. the testing point is where Pin7,8 approaches the encapsulation cover	
2. Pin7, 8 is connected on two ounces of tinning copper, and the area of copper is not less than 200mm ² .	

Diagram of the dimension of encapsulation (DIP8)

DIP-8

Unit: mm(inch)

