

## Advanced Power Management Unit

### FEATURES

- Three Step-Down DC/DC Converters
- Four Low-Dropout Linear Regulators
- I<sup>2</sup>C™ Serial Interface
- Advanced Enable/Disable Sequencing Controller
- Minimal External Components
- Tiny 4x4mm TQFN44-32 Package
  - 0.75mm Package Height
  - Pb-Free and RoHS Compliant

### GENERAL DESCRIPTION

The ACT8892 is a complete, cost effective, highly-efficient *ActivePMU™* power management solution that is ideal for a wide range of high performance portable handheld applications such as tablet or pad devices.

This device features three step-down DC/DC converters and four low-noise, low-dropout linear regulators.

The three DC/DC converters utilize a high-efficiency, fixed-frequency (2MHz), current-mode PWM control architecture that requires a minimum number of external components. Two DC/DCs are capable of supplying up to 1150mA of output current, while the third supports up to 1300mA. All four low-dropout linear regulators are high-performance, low-noise, regulators that supply up to 320mA.

The ACT8892 is available in a compact, Pb-Free and RoHS-compliant TQFN44-32 package.

### TYPICAL APPLICATION DIAGRAM

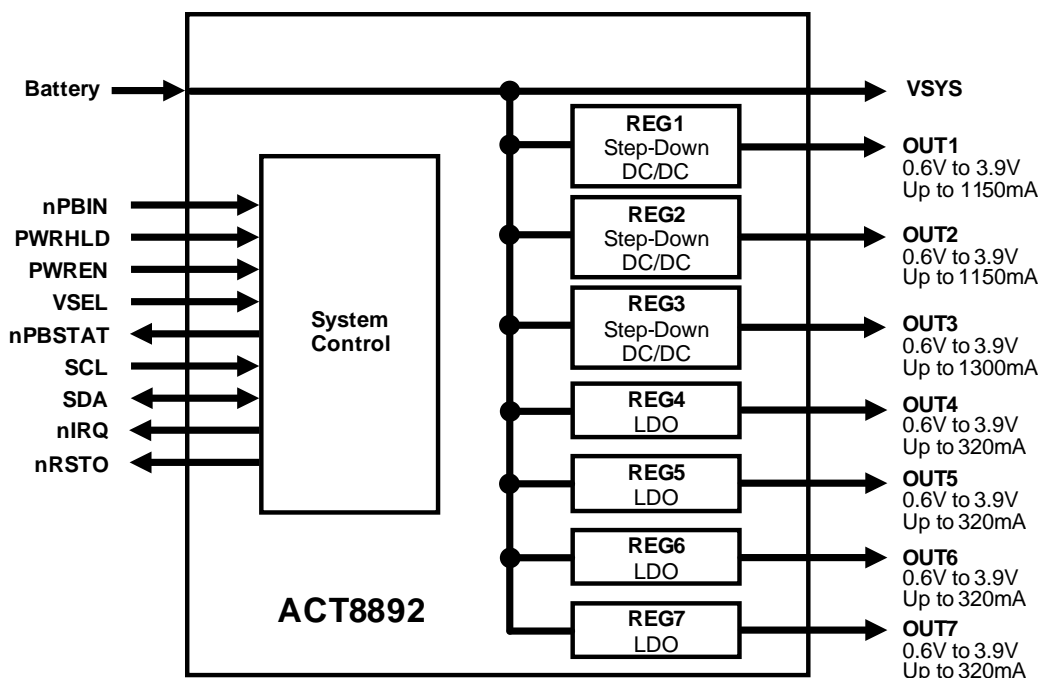

**PRODUCT OPTIONS**

Block	Function	Output Voltage	Capability
REG1	Step-Down DC/DC	0.6V to 3.9V	1150mA
REG2	Step-Down DC/DC	0.6V to 3.9V	1150mA
REG3	Step-Down DC/DC	0.6V to 3.9V	1300mA
REG4	Low-Noise LDO	0.6V to 3.9V	320mA
REG5	Low-Noise LDO	0.6V to 3.9V	320mA
REG6	Low-Noise LDO	0.6V to 3.9V	320mA
REG7	Low-Noise LDO	0.6V to 3.9V	320mA

**FUNCTIONAL BLOCK DIAGRAM**

