

Preliminary

GENERAL DESCRIPTION

EM92100/EM92101 is a set of 4-bit micro-controller specially designed for 10-channel Auto-Scan cordless phone. It consists of all operational features of existing cordless phone. Both of the handset unit and base unit with LCD display. RTC (real time clock), dialing number, channel number and check memory function.

FEATURES

- Watch dog timer function.
- BASE unit with 16 digits LCD display. (Date, Real time clock, conversation time, dialing number, function flag)
- Handset unit with 12 digits LCD display. (Real time clock, conversation time, dialing number, function flag)
- Base unit with receiver when no power supply, Base unit still can be used.
- Check last conversation and reset STW function.
- RF Module provided.
- 10 different channels changeable with parallel PLL EM92600 series interface.
- 16 bits random security code.
- Handset and Base set security code programmable.
- Handset unit RF power saving control enter slow mode work at 32768 Hz crystal to reduce 4 bit micro controller power consumption.
- Individual keypad for handset and base unit.
- Base unit speakerphone function.
- Auto on / auto standby function.
- Handset turn on by any key while ring incoming.
- Line holding and call transferring.
- Carrier sense. (auto turn off after 20 seconds and warning beep every 5 seconds while talking ; beep tone only provided by Handset.
- Handset keypad backlighted.
- Two ways paging and intercoming (direct intercom from handset to base).
- Battery low detection and indication.
- Testing mode by key for production alignment. (Voice and data DTMF, carrier detection indicator modulation test for each CH, Tx and Rx path test.
- Changeable receiving sound volume (normal or loud) by soft key at handset unit.
- Selectable Tone/Pulse, M/B ratio ; 10 PPS provided only.
- Selectable flash time, 600ms, and 100ms R-option.
- 3.6 seconds pause key and tone mode soft key change.
- Built-in DTMF generator.
- Two 32-digit redial buffers (one in Handset and one in Base).
- 3 sets of direct memory (32 digits) and 10 sets of indirect memory (16 digits) on each units.
- One key redial function.
- Standby state key in, normal state auto dial out function provided.
- Standby state check memory, normal state auto dial out function.
- Standby state redial content check function (last 10 sets). Normal state auto dialout function.
- Handset unit charge ID code transmit to Base set or not, selectable.
- CHK key function, used to check channel number, LNB, memory, etc.

Preliminary

- Provide by chip form or QFP 80 pins package.
- 4 MHz and 32768 Hz crystal system.

APPLICATIONS

10 channel auto Scan cordless phone

PIN ASSIGNMENTS

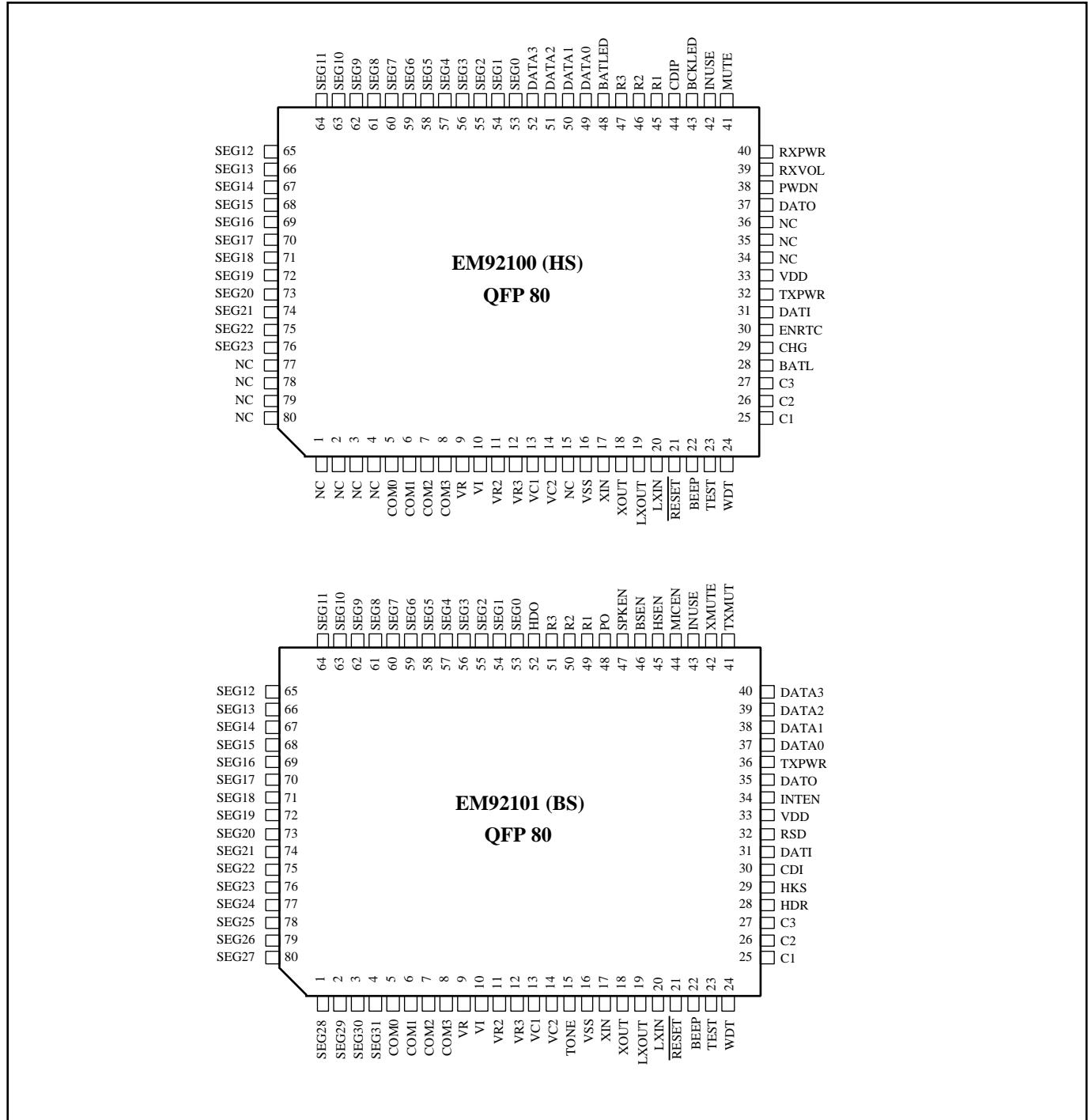

* This specification are subject to be changed without notice.

Preliminary

KEYBOARD ARRANGEMENT

Handset unit keypad (EM92100)

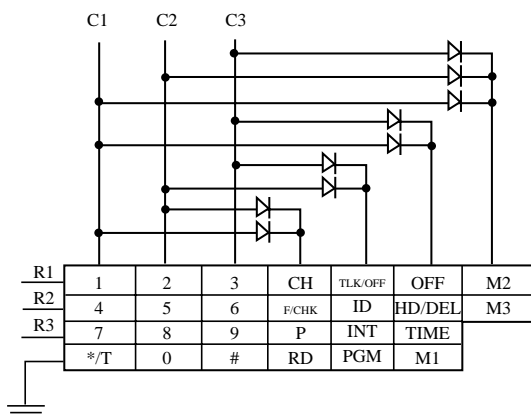

Base unit keypad (EM92101)

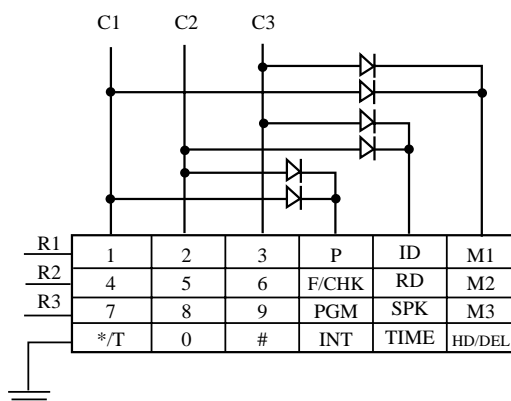

KEY DESCRIPTION

Key Name	Description
ID	ON-Hook, check ID code. Press, "PGM" key, then "ID" key to setup ID code.
TLK/OFF	Talk key and standby key, TLK and OFF.
INT (Handset)	Intercom
PGM	Memory program (store and recall)
M1 - M3	Direct memory
HD/DEL	Line hold/Predial edit key.
CH	Channel change
F/CHK	Flash/Check memory
P	Pause
*/T	"**" and Tone mode soft key
RD	Redial
0 - 9	Numeric key and indirect memory location key
SPK	Speaker phone On/Off
INT (Base)	Paging/Intercom
TIME	ON-HOOK, Check conversation time OFF-HOOK, Reset STW time

PIN DESCRIPTIONS

Handset unit (EM92100)

Symbol	I/O	Active	Function
C1-C3	I (P.U.)	-	Keyboard column scan pins. Built in 20ms key-press and key-release debounce time.
R1-R3	I/O (P.P.)	-	Keyboard row scan pins.
DATA0~3	O (P.P.)	H	Channel select output. It outputs 4-bit BCD code from 0001 to 1010 to control the external PLL such as EM92600A/C series for 46/49MHz or 45/48MHz band to work in one of 10 channels.
BEEP	O (P.P.)	H	Beep function output. The BEEP pin generates the beep tone such as key tone, incoming ring, paging and warning tone, etc. The BEEP frequency is 1KHz, 2KHz.

* This specification are subject to be changed without notice.

Preliminary

Symbol	I/O	Active	Function
/MUTE	O (O.D.)	L	Transmission and Receiver mute output. /MUTE outputs a low signal to disable the microphone and speaker or send a low signal to compressor for transmission muting.
/TXPWR	O (O.D.)	L	RF transmitter power control output. The RF transmitter power can be controlled by this pin. It outputs high signal to RF transmitter in stand-by mode and sends low signal in in-use mode.
/RXPWR	O (O.D.)	L	RF receiver power control output. The RF receiver power is controlled by this pin at a ratio of 1:2 (min. 1 sec ON) when the handset is in standby mode and at receive off time system run at slow mode by 32768 crystal run at very low power consumption. This function is called “power saving”. /RXPWR goes low in in-use mode and low/high (ON/OFF) ratio of 1:2 in standby mode.
/INUSE	O (O.D.)	L	Talk mode indicator. It sinks current to drive an LED directly in talk mode and toggles to flash LED where in line hold mode.
/BCKLED	O (O.D.)	L	Keypad backlight indicator. For the power saving consideration, the /BCKLED will only be kept low for 8 seconds after each dialing key pressed. It also toggles to flash the LED during incoming ring or paging from base unit, selected by R option.
/BATLED	O (O.D.)	L	Battery low indicator. It indicates the low battery condition. It sinks current to drive an LED directly when /BATL pin is low and in in-use mode.
/BATL	I	L	Battery low detection input. A low input to this pin when battery is low. This pin only functions when in in-use mode. (/TXPWR=low).
/CDI	I	L	Carrier sense input. It works when /TXPWR=low and /RXPWR=low to sense the RF carrier. In normal air-linked condition, the external RF carrier detection circuit must has a low level signal input to /CDI pin. When there is no RF carrier detected (/CDI=high), beep tone from /BEEP pin will be activated every 5 seconds. If the carrier is lost for more than 20 seconds, the handset will return to standby mode automatically. High input to this pin disable the backlight during ringing and paging in order to save power from flashing backlight.
NC	-	-	No connection.
XIN, XOUT	-	-	Oscillator Input/Output. A 4MHz crystal is required, two 10pF capacitors should be connected from XIN and XOUT to ground respectively.
/RESET	I (O.D.)	L	System reset input. Low input to this pin resets the controller. The system reset can be done when the first time power up or putting the handset on the charge cradle. To reset the controller, a minimum of 10ms low pulse is required. If the handset battery is to be changed, a low signal should be detected PWDN

Preliminary

Symbol	I/O	Active	Function
			pin that forces the controller to enter sleep mode. But the /RESET pin should be kept high with power back up circuit in order to maintain the controller memory. /RESET pin should be pulled high whereas in-use or standby mode to conserve power.
PWDN	I	L	Power down det pin. When no power, enter sleep mode to protect memory.
CHG	I	H	Charge detection input. High input indicates charging mode. If select R option TXID active . It is used for system alignment when the handset is placed back to the base charge cradle. It needs about 2 seconds for the alignment. If R option not TXID, when charge will not do alignment.
WDT	I (O.D)	L	Watch dog timer. Connect to Reset pin to prevent IC malfunction. When system error, this pin will output low for system reset.
/DATI	I	L	Data input. The data sent from the sending-end where is inverted to the receiving-end, that it means to receive the inverted signal sent from the base's DATO pin. To prevent IC malfunction from RF noise, a low pass filter (cut off freq. ~ 1kHz) must be added, see figure 1. A low signal sent to this pin will force the controller to start sampling the received data.
DATO	O (P.P.)	H	Data output. It sends the digital data of dialing and commands to the base unit. The base unit should invert this signal firstly before sending to base's /DATI pin. The maximum data rate is 250Hz.
V_{DD}, V_{SS}	-	-	Power supply. Supply voltage ranges from 2.4V to 5.5V DC. Recommend a 0.1uF decouple capacitor is connected between its V_{DD} and V_{SS} .
TEST	I	-	This pin is reserved for IC fabrication test purpose. It must be connected to V_{SS} .
LXOUT, LXIN	-	-	Oscillator input/output. Connect 32768 Hz crystal two 20pF capacitors should be connected from LXOUT, LXIN to ground respectively.
RXVOL	O (O.D)	L	At TLK, OFF separate mode. key in TLK will toggle this pin, to control Handset volumn.
VI, VR, VR2, VR3 VC1, VC2	O	-	Voltage doubler output pin for capacitor connection and LCD voltage control.
COM0~3	O	-	Common pins for LCD driver.
SEG0~23	O	-	Segment pins for LCD driver.
ENRTC	I	-	When connect this pin to " V_{SS} ", enable RTC connect this pin to " V_{DD} ", disable RTC.

Preliminary

Base Unit (EM92101)

Symbol	I/O	Active	Function
V_{DD}, V_{SS}	-	-	Power supply. Supply voltage ranges from 2.4V to 5.5V DC. V_{SS} is always grounded. Recommend a 0.1uF decouple capacitor connected between its V_{DD} and V_{SS} .
XIN, XOUT LXIN, LXOUT	-	-	Oscillator input/output. A 32768 crystal must be connected to LXIN, LXOUT. and a 4MHz crystal must be connected between XIN, XOUT. Two 10pf capacitors are connected to XIN, XOUT for oscillation respectively. Two 20 pF capacitor are connected to LXIN, LOUT.
/RESET	I (O.D.)	L	System reset input. High input to this pin for normal operation, and low input to this pin to reset the controller. The system reset can be done at the first power up or putting the handset on the charge cradle. The minimum reset pulse width is 10ms. But the /RESET pin should be kept high with power back up circuit in order to maintain the controller memory. It must be pulled high whereas in-use or standby mode to conserve power.
C1-C3	I (P.U.)	-	keyboard matrix column. Column input of key matrix, with 20ms internal debounce.
R1-R3	I/O (P.P.)	-	Keyboard matrix row. Row input of key matrix, with 20ms internal debounce.
DATA0~3	O (P.P.)	H	Channel select output. It outputs 4-bit BCD code from 0001 to 1010 to control the external PLL such as EM92600A/C series for 46/49MHz or 45/48MHz band to work in one of 10 channels.
/TXMUT	O (O.D.)	L	Transmission mute output. The /TXMUT outputs a low signal to compressor for transmission muting. It can also be connected to expander for expansion muting simultaneously.
/DATI	I	L	Data input. The data sent from the sending-end where is inverted to the receiving-end, that it means to receive the inverted signal sent from the handset's DATO pin. To prevent IC malfunction from RF noise, a low pass filter (cut off freq. ~ 1kHz) must be added, see figure 1. A low signal sent to this pin will force the controller to start sampling the received data.
DATO	O (P.P.)	H	Data output. It sends the digital data such as ringing or paging command to the handset unit. The base unit should invert this signal firstly before sending to handset's /DATI pin. The maximum data rate is 250Hz.
/TXPWR	O (O.D.)	L	RF transmitter power control output. The RF transmitter power can be controlled by /TXPWR pin. It goes low when in in-use mode.
BEEP	O (P.P.)	H	Beep function output. The BEEP pin generates the beep functions such as key tone, incoming ring, paging and warning tone, etc. The frequencies of beep output is 1KHz or 2KHz.

Preliminary

Symbol	I/O	Active	Function
INUSE	O (P.P.)	H	In-use indicator. High output when the handset or the base unit is being used.
/CDI	I	L	Carrier detect input. This pin senses the RF carrier of the air-link. It functions when the /TXPWR=low which implies that air-link ready between handset and base unit. If it detects no RF carrier (/CDI input high) for more than 20 seconds, the base unit returns to standby automatically. In normal air-linked condition, the external RF carrier detection circuit must set the /CDI pin to low.
TONE	O	H	DTMF signal output. In base unit dialing, the DTMF signal is generated as long as the key is pressed. For handset dialing and speed dialing, the DTMF signal complies with minimum tone duration (100ms) and minimum inter-tone pause (100ms).
WDT	O (O.D)	L	To protect IC. Watch dog timer. Connect to Reset pin to prevent IC malfunction. When system error, this pin will output "LOW" for system reset..
HKS	I (O.D)	L	Hook switch detect input pin. Input low off-Hook, Input high ON-Hook.
VI, VR, VR2, VR3 VC1, VC2	O	-	Voltage output pin for capacitor connection and LCD voltage control.
COM0~3	O	-	Common pins for LCD driver.
SEG0~SEG31	O	-	Segment pins for LCD driver.
PO	O (O.D)	L	Telephone line connection output. Open drain structure. For loop connection. It also outputs pulse dialing or flash (line break) signals.
/XMUTE	O (O.D.)	L	DTMF and pulse dialing signal mute output. The XMUTE pin executes the transmission mute of the DTMF and pulse signal dialing out.
HSEN	O (P.P.)	H	Handset in-use audio signal switch output. To turn on the audio path for handset line where in-use.
BSEN	O (P.P.)	H	Base speakerphone audio signal switch output. To turn on the audio path for base unit making or receiving a call.
INTEN	O (P.P.)	H	Intercom audio signal switch output. To turn on the audio path for intercom between handset and base unit.
HDO	O (P.P.)	H	Line hold output for music control. The HDO outputs high when line is hold. It may also be used to control a music generator while line holding.
/SPKEN	O (O.D.)	L	Speaker amplifier power control output. Output low to enable the power for speaker amplifier.
/MICEN	O (O.D.)	L	Microphone amplifier power control output. Output low to enable the power for microphone amplifier. It is also used to execute microphone mute function.
/HDR	I	L	Hold release input pin, the internal debounce time is 48 ms. When this pin detects "low" will release hold mode.
/RSD	I	L	Ring signal envelope detection input. It detects the envelope of of incoming ring whether a ring is present or not. In normal no ringing condition, a high level signal input to this pin. If line ringing happens, input low for ring-on and input high for ring-off.

Preliminary

Symbol	I/O	Active	Function
TEST	I	-	This pin is reserved for IC fabrication test purpose. It must be connected to V_{SS} .

NOTE : P.P. : Push pull
 O.D. : Open drain, implies a pull up resistor is required.
 P.U. : Pull up resistor inside.

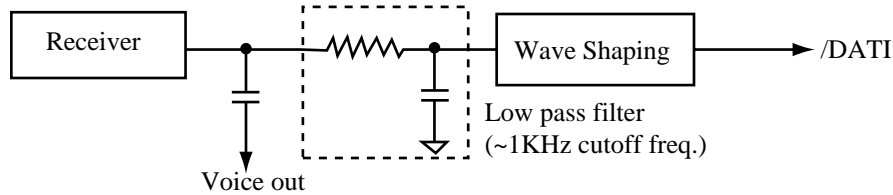

Figure 1. Low pass filter interface

R-option Description

Changing option in base unit

The base unit provides the R-option in its row and column pins to setup different options in operation. To select the option, connect a 560k ohm resistor from specific row and column pins to V_{SS} , as described below.

Note : NR -- no resistor to be connected. R- V_{SS} -- connects a 560k ohms resistor to V_{SS} .

Changing option in Base unit :

R1	mode	R2	M/B	R3	Flash time	C1	Lock
NR	Tone	NR	40:60	NR	600 ms	NR	-
R- V_{SS}	pulse	R- V_{SS}	33:66	R- V_{SS}	100 ms	R	"0"
				C2	Hour format		
				NR	12 hour		
				R	24 hour		
				C3	Ring SW		
				NR	ON		
				R	OFF		

Changing option in Handset :

R1	Talk OFF key	R3	Back light	C1	Hour format	C2	TXID
NR	Tlk;OFF	NR	No	NR	12 Hour	NR	Yes
R- V_{SS}	TLK/OFF	R- V_{SS}	Yes	R	24 Hour	R	No
				C3	Ring SW		
				NR	ON		
				R	OFF		
R2	Lock						
NR	-						
R	"0"						

Preliminary

LCD display format :

Hand set LCD panel :

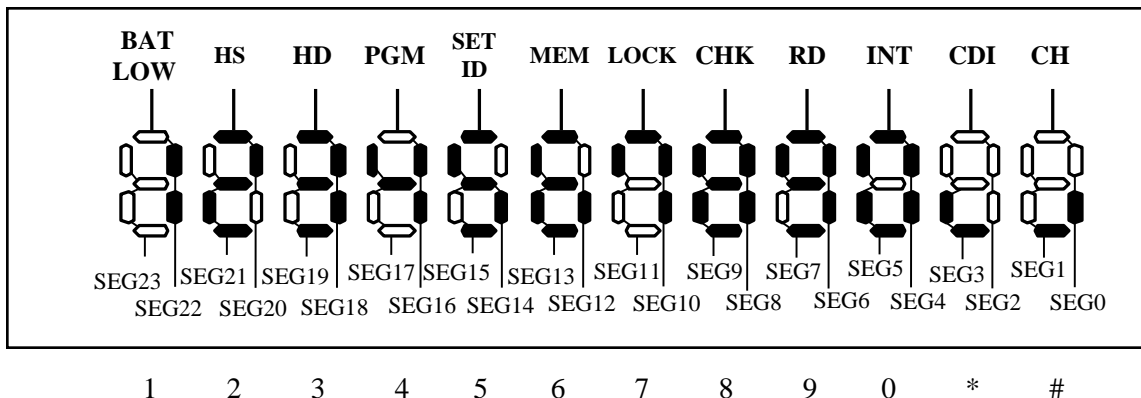

Base LCD panel :

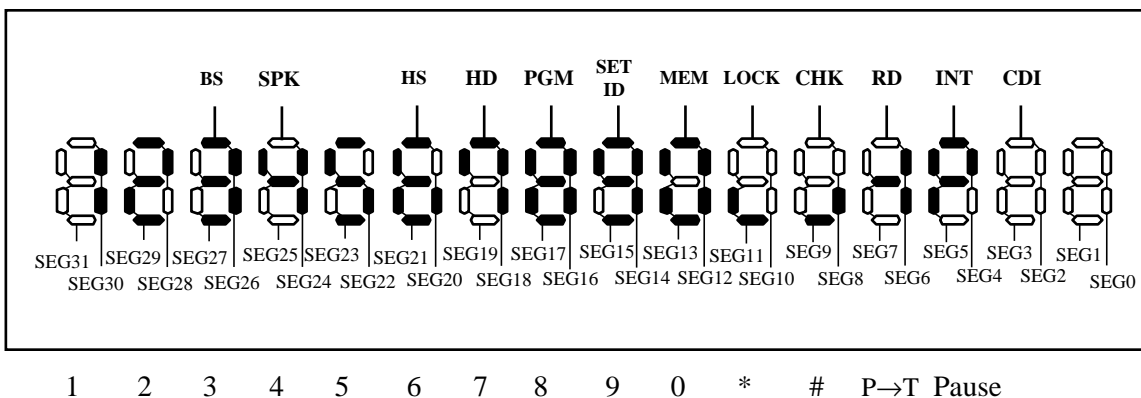

The LCD driving voltage structure :

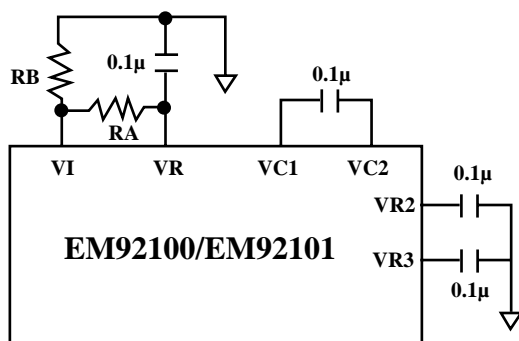

$$\text{Operating voltage} = 3 * \text{VR}$$

$$\text{VR} = \frac{0.6 (RA + RB)}{RB}$$

by adjust RA and RB can fit different LCD panel operating voltage. If the LCD panel is operating at 4.5V, then the recommended RA=1.5MΩ RB=1MΩ.

Preliminary

LCD Panel Outline Drawing :

Handset :

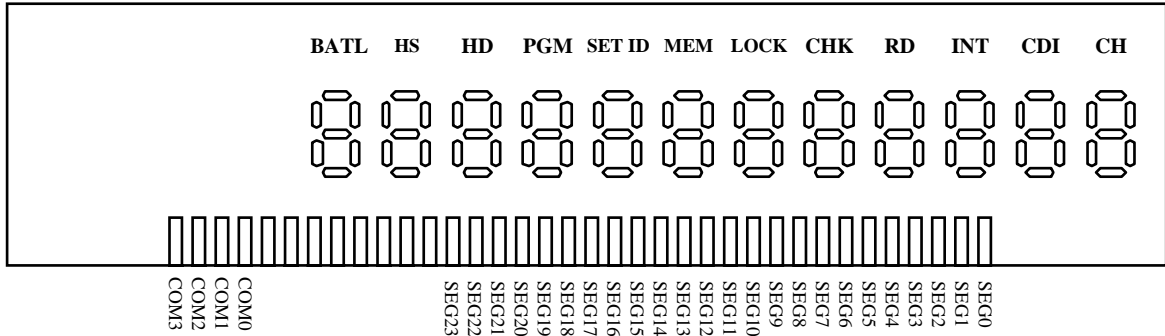

Base :

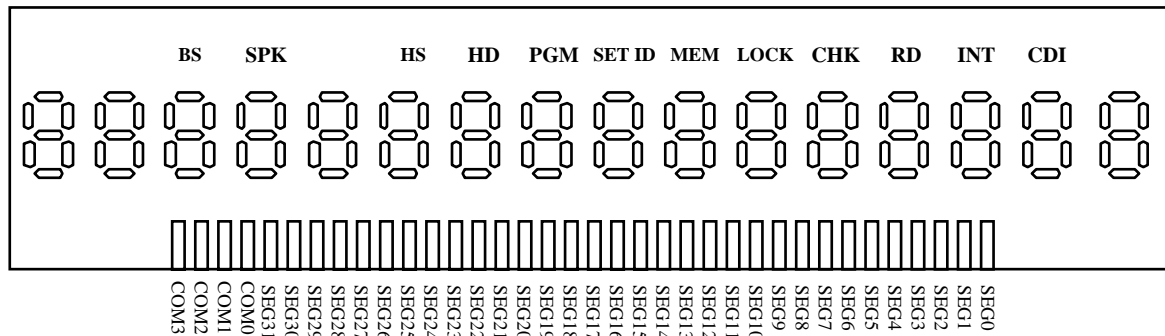

LCD Panel Writing Diagram :

Handset :

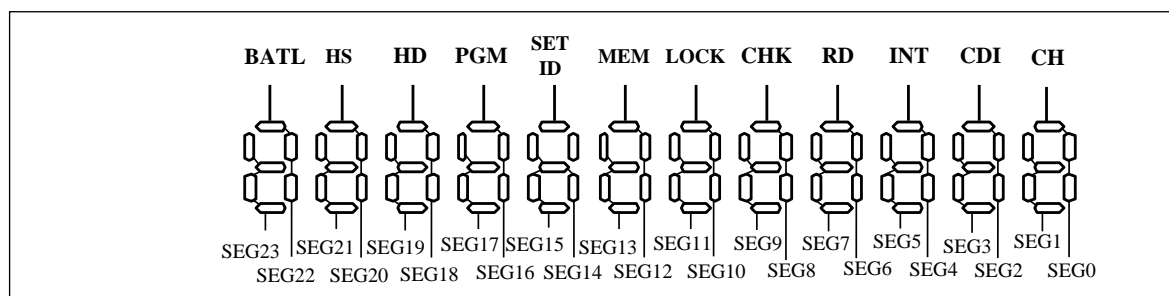
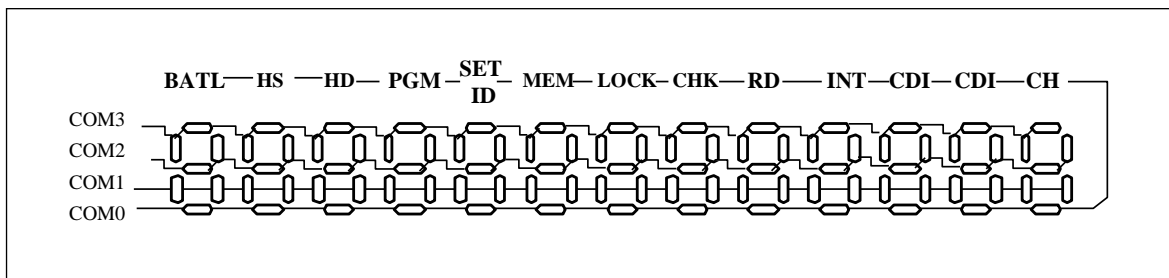

Preliminary

Base :

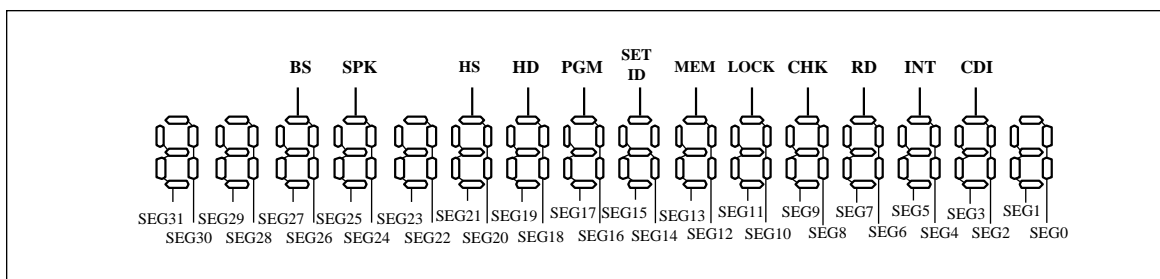
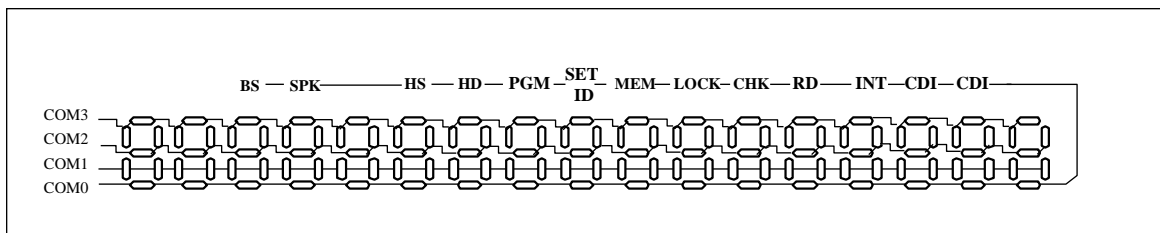

FUNCTION DESCRIPTIONS

System setup when Initial Use

Before using the handset when first time power up, the ID code and channel setting must be aligned between handset and base unit. It can be done by two way :

1. Auto setup :

Select "TXID" by not connect a 560kΩ resistor to C2 (Handset) when put the Handset on charge cradle for more than 2 seconds. After the alignment finished, a beep sound will be generated by the handset unit. This setup runs automatically whenever the handset is placed back to the charge cradle.

- a. Power up and "PWDN" pin detects high.
- b. Put the handset on the charge cradle for more than 2 seconds.
- c. A short beep sound generated from the handset when system alignment finished.

2. Manual setup :

Select "TXID" by connect a 560kΩ resistor to C2 (Handset) when put the Handset on charge cradle will not do the ID code and channel alignment. The ID code and channel can be aligned by following procedure :

At handset unit :

- a. Take the handset unit away from the charge cradle.
- b. Press "PGM", then "ID", the LCD display :

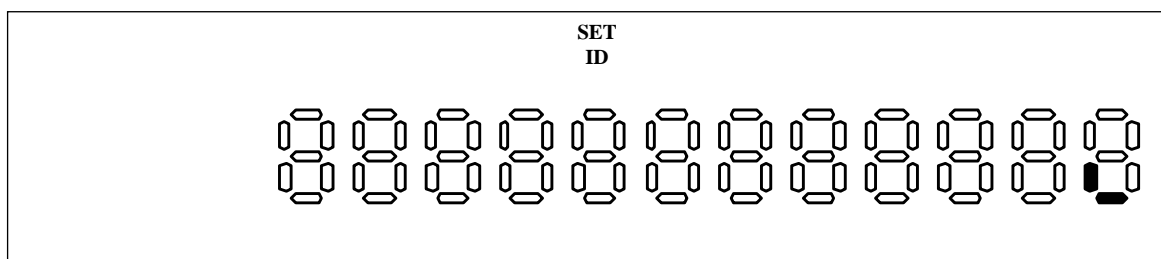

Preliminary

3. Press 4 digits ID code. If press ID code is "8888" will finish the ID code setting and a beep tone will issue the LCD display :

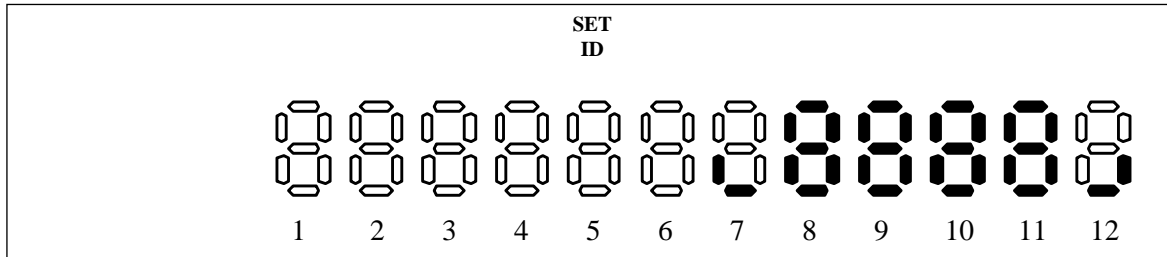

At Base Unit :

1. Press "PGM", then "ID" key.
2. Press 4 digits ID code, the ID code must be the same with Handset unit. When finish the ID code setting and a beep tone will issue. The LCD display is the same as Handset. Then the ID code and channel between Handset and Base unit are aligned.

Making calls :

At Handset Unit :

1. "TLK", "OFF" key separated :
 - a. Press "TLK" waiting for radio link.
 - b. Dial the numbers.
 - c. Line conversation.
 - d. Press "OFF" to disconnect or place he handset on charge cradle directly.
2. "TLK", "OFF" combined
 - a. Prees "TLK/OFF" key, waiting for radio link.
 - b. Dial the numbers.
 - c. Line conversation.
 - d. Press "TLK/OFF" to disconnect or place the handset on charge cradle directly.

At Base Unit :

1. OFF HOOK or press "SPK".
2. Dial the numbers.
3. Line conversation.
4. ON HOOK or press "SPK" again to disconnect.

LNB Redial Function :

Storing :

In normal dialing mode, every digital key was entry which number will be stored in LNB memory automatically. If entry digits are more than 32 digits, the redial function of LNB memory will be disabled, otherwise, these numbers stored in LNB memory can be redial output.

Preliminary

Redialing :

(1) Redial function :

At normal dialing directly keying "F" key (or first turn on line) and key-in "RD" key. The numbers stored in LNB memory will be dialed out.

(2) One key redial function :

At normal dialing, if line at busy, directly keying "RD" the line will be broken about 1.6 sec and dial out the numbers stored in LNB memory automatically.

Pause(P) key operation :

The Pause(P) key is designed to support pause operation in dialing duration. "P" key can be stored in memory and it will occupy one digital position.

- To select Pulse or Tone mode.
- At normal dialing, push (d1, d2, ..., dn, k1, k2, ..., kn). These numbers will be dialed out as following sequence :

d1, d2, ..., dn, Tp, k1, k2, ..., kn.
(pulse mode) (tone mode)

Flash(F) key operation :

The Flash(F) key is designed to break telephone line temporarily. After key is depressed, this dialer will send a flash signal to break line 600ms or 100ms selected by R option (R3, at BASE unit)

• **Receiving calls**

At handset unit

1. When you hear the ring, press **TEL** or any other key exception **OFF**
(If handset in charge mode pick up the handset unit from charge cradle directly)
2. Line conversation
3. Press **OFF** to disconnect or place the handset on charge cradle directly.

At base unit

1. When you hear the ring, OFF HOOK or press **HF**
2. Line conversation
3. ON HOOK or press **HF** again to disconnect

• **Memory program**

Note:

1. All of the numbers are stored into base unit controller when memory program.
2. Do not more than 10 sec, between any two steps of the programming procedure.
3. The numbers to be stored must within 32 digits for one touch memory; 16 digits for two touch memory,

To store the numbers at handset

1. Press **PGM**

Preliminary

2. Press the numbers to be stored.
3. Press **PGM**
4. Press the memory stations **0** ~ **9** two touch (indirect) memory or **M1** ~ **M3** one touch (direct) memory.

Note: If the step 2 of procedure is skipped which performs the memory clear.

To store the numbers at base

1. Press **PGM**
2. Press the numbers to be stored.
3. Press **PGM**
4. Press the memory stations **0** ~ **9** two touch (indirect) memory or **M1** ~ **M3** one touch (direct) memory.

Note: If the step 2 of procedure is skipped which performs the memory clear.

To recall the memoy at handset

1. Press **TEL** , waiting for radio link,
2. Press **M1** ~ **M3** one touch (direct) memory or **PGM** , **0** ~ **9** two touch (indirect)memory

To recall the memory at base

1. OFF HOOK or press HF
2. Press **M1** ~ **M3** one touch (direct) memory or **PGM** , **0** ~ **9** two touch (indirect) memory.

• Paging/Intercom**To call base from handset**

1. Handset press **INT** , waiting for radio link.
2. Handset and Base unit output B.B and Base unit directly turn on speaker phone enter intercom mode.
3. End of this call, handset press **OFF**

To call handset from base

1. Base press **INT** , waiting for radio link.
2. Handset and base intercom, ring continuously.
3. Handset unit press **INT** or any other key exception **OFF** .
4. Intercom conversation.
5. END of this call base unit press **HF** .

• Receive an incoming call during intercom

1. Handset unit and Base unit intercom conversation.
2. When ring comes in, base unit "INUSE" LED blinking.
3. Handset press **TEL** to answer the call on the handset unit.
4. Base unit press **INT** key to end of this intercom conversation and to answer the external call on Base unit.

• Change channel for better reception

Preliminary

1. When hear interference during conversation on Handset unit.
2. Handset press (CH) , conversation interrupted about 1 sec.
3. New channel conversation.

• Call transfer by Hold function

From base to base

1. Handset line conversation, press (HD)
2. Line hold.
3. Base unit OFF HOOK or press (HF)
4. The call has been transferred and base unit line conversation.

From base to handset

1. Base line conversation, press (HD)
2. Line hold.
3. Handset unit press (TEL) , waiting for radio link.
4. The call has been transferred and handset unit line conversation.

LC display function

The EM92100/EM92101 provide the LCD display function which included modem mobile phone operation. The LCD display function is described as the following :

- (1) RTC (Real time clock) display function

At handset unit :

When at idle state RTC display function enable, the system will enter RTC display mode. There are two kinds of RTC format selected by R option. 12 hour format or 24 hour format.

12 hour format

P 2 : 56 : 28

24 hour format

14 : 56 : 28

Preliminary

After 6 sec STW display :
At handset unit:

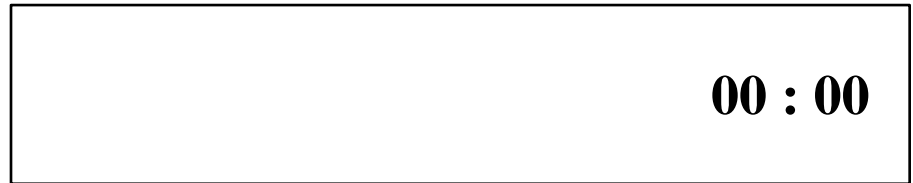

At BASE unit:

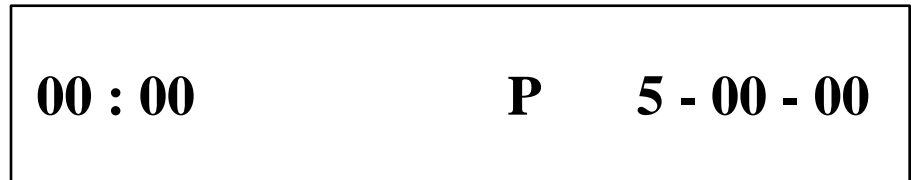

(5) Check memory function

The EM92100/EM92101 provide check memory function. When at idle state, directly key in "Mn" (n=1~3) or "CHK" and the memory location "n" (0~9) or Mn(n=1~3), then the content of memory will display on LCD panel for 6 sec. If during the period of time, turn on the line, the numbers which display on LCD panel will be dialed out automatically.

(6) Pre-dial function

When at idle state, directly key in digits, and the digits will display on LCD panel from right to left. After last digits key in, the LCD panel will display number for 6 sec. If during the period of time turn on the line, the numbers will be dialed out, otherwise, the system will back to RTC mode and these numbers will not copy to LNB.

(7) SCROLL function

The EM92100/EM92101 can check the last 10 sets dialed numbers. The first 16 digits LNB content will be copied to SCROLL buffer automatically, and first in last out. When at idle state, key in "RD" key can check the last 10 sets LNB one by one. If the LCD panel display the number that you need. Off-Hook or turn on HF in 6 sec directly, and the phone number will be dialed out.

(8) Number edit function (at idle state)

All the pre-dial numbers which display on hte LCD panel, can be edited. After Off-Hook or turn on HF, the modified numbers will be dialed out automatically. This function is controlled by "DEL" key, when key in once, the digits display on LCD panel will be back from left to right one digit to modify the pre-dial numbers.

RTC time setup method

To seup RTC time, execute the following steps :

- (1) Confirm that you are at idle state.
- (2) Key in "PGM", "TIME" key

- The EM92100/EM92101 will enter calendar (only for base unit) and real time clock setup mode.
- In this mode, the high-position of month of calendar will be flashing, prompting you to enter data at this position.

Preliminary

In the flashing position :

(3) Press MM,DD, */#, hh, mm.

- (MM for Month, DD for Day, * for AM, # for PM, hh, for hour, mm for minute)
- If the data is valid entry, the key tone will be emitted and the flashing position will shift to next position until this setup is completed.

LCD ICON Display

Handset unit :

ICON	Condition	Display
CH	(1) Handset turn on lin	ON
	(2) Otherwise	OFF
CDI	(1) with carrier detect	OFF
	(2) no carrier detect	ON
INT	(1) INT pin output high	ON
	(2) Otherwise	OFF
RD	Execute redial functio	ON
	Otherwise	OFF
CHK	Execute CHECK function	ON
	Otherwise	OFF
LOCK	Execute LOCK function	ON
	Otherwise	OFF
MEM	Memory dialing	ON
	Otherwise	OFF
SET ID	ID code setting	ON
	Otherwise	OFF
PGM	Press PGM key	ON
	Otherwise	OFF
HD	At Hold line mode	ON
	Otherwise	OFF
HS	Handset using line	ON
	Otherwise	OFF
BATL	BATL pin detect low	ON
	Otherwise	OFF

BASE unit :

ICON	Condition	Display
CDI	(1) with carrier detect	OFF
	(2) no carrier detect	ON
INT	(3) INT pin output high	ON
	(4) Otherwise	OFF
RD	Execute redial functio	ON
	Otherwise	OFF
CHK	Execute CHECK function	ON
	Otherwise	OFF
LOCK	Execute LOCK function	ON
	Otherwise	OFF



Preliminary

MEM	Memory dialing Otherwise	ON OFF
SET ID	ID code setting Otherwise	ON OFF
PGM	Press PGM key Otherwise	ON OFF
HD	At Hold line mode Otherwise	ON OFF
HS	Handset using line Otherwise	ON OFF
SPK	Speaker phone on Otherwise	ON OFF
BS	BASE unit using line Otherwise	ON OFF

Preliminary

ABSOLUTE MAXIMUM RATINGS (EM92100, EM92101)

Items	Sym.	Condition	Rating
Supply voltage	V _{DD}		- 0.5V to 5.5V
Input voltage	V _{IN}		- 0.5V to V _{DD} +0.5V
Output voltage	V _O		- 0.5V to V _{DD} +0.5V
Power dissipation	P _D	T _{opr} = 50°C	300 mW
Operating temperature	T _{OPR}		0°C to 50°C
Storage temperature	T _{STR}		-55°C to 125°C

RECOMMENDED OPERATING CONDITIONS (EM92100/EM92101)

Items	Sym.	Condition	Rating
Supply voltage	V _{DD}	F _C =4.0MHz	2.4V to 5.5V
Input voltage	V _{IH}		V _{DD} *0.9 to V _{DD}
	V _{IL}		0V to V _{DD} *0.1
Operating Frequency	F _C	crystal OSC	4.0 MHz

DC ELECTRICAL CHARACTERISTICS (EM92100,EM92101)

(V_{DD} = 5.0±0.5V, V_{SS} = 0V;T_{opr} = -30°C to 70 °C)

Parameter	Sym.	Condition	Min.	Typ.	Max.	Unit
Supply current	I _{DD}	V _{DD} =5.5V,fc=4MHz	-	2.5	5	mA
Standby current	I _{STB}	V _{DD} =5.5V, sleep mode	-	0.1	1	μA
Input current	I _{IN}	V _{DD} =5.5V,V _{IN} =5.5V(leakage)	-	-	1	μA
Output current	I _{OH}	V _{DD} =4.5V,V _{OH} =2.4V	-	-250	-	μA
	I _{OL}	V _{DD} =4.5V,V _{OL} =0.4V others	2	-	-	mA

DTMF CHARACTERISTICS (EM92101) (V_{SS} = 0V,V_{DD} = 4.5V,T_{OPR} = -30°C to 70°C)

Symbol	Description	Min.	Typ.	Max.	Unit
PEHB	PEHB=20 LOG(COL/ROW)	1	2	3	dB
Vtone	RL > 10 Kohms,V _{DD} =2.7V(ROW)	120	150	180	mVrms
DIS*	Distortion	-	-30	-23	dB
Ftone(DTMF)	Stability, except error of OSC	-	-	0.7	%

- COL: Amplitude of column group frequencies.
- ROW: Amplitude of row group frequencies.

$$\text{Distortion(dB)} = 20 \log \frac{\sqrt{V_1^2 + V_2^2 + \dots + V_n^2}}{\sqrt{V_h^2 + V_l^2}}$$

V₁, V₂,, V_n are the amplitude of harmonic components within 300Hz~3500Hz.

V_l, V_h are the amplitude of row group frequency and column group frequency respectively.

Preliminary

AC CHARACTERISTICS ($V_{DD}-V_{SS}=4.5V, F_{osc}=4.0MHz$, all output unloaded)

Parameter	Sym	Condition	Min.	Typ.	Max.	Unit
Pulse rate	PSR		—	10	—	PPS
Make/Break ratio	MBR	R2="NR"	—	40/60	—	%
		R2="R- V_{SS} "	—	33/66	—	%
Inter-digit pause time	Tidp	10 PPS	—	800	—	ms
Pause (pulse to tone wait time)	Tp		—	3.6	—	sec
Flash time	Tf	R3="R- V_{SS} "	—	100	—	ms
		R3="NR"	—	600	—	ms
Flash pause time	Tfp		—	800	—	ms
Minimum tone duration/inter-tone pause	Td/Titp	(Tone mode)	—	100/100	—	ms
Redial break time	Trdb	One key redial	—	1.6	—	sec
Redial pause time	Trdp	One key redial	—	800	—	sec
Key-in/key-release debounce time	Tdb		—	20	—	ms

NOTE :For more details about electrical characteristics, please refer to EM73-series 4-bit microcontroller specification.

Preliminary

TIMING DIAGRAM

DTMF signals

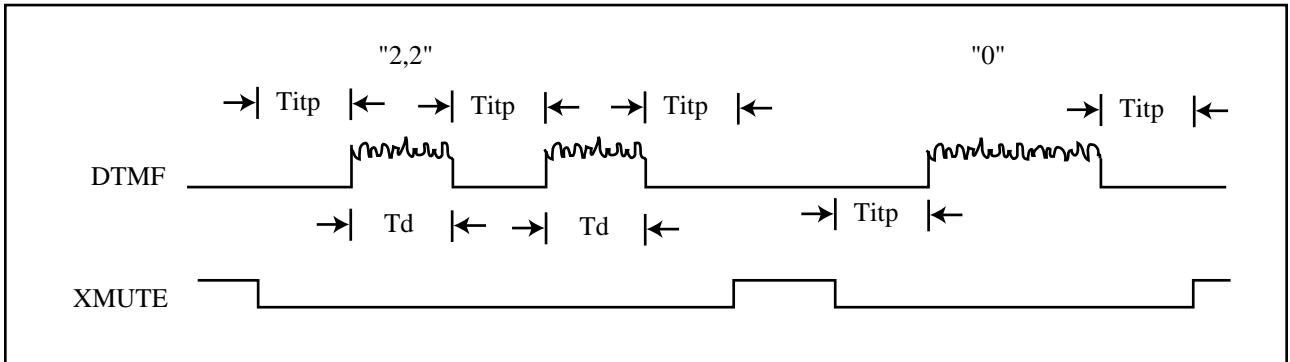

Note : The DTMF signals are always with minimum tone duration and minimum inter-tone pause in handset dialing.

Pulse Dialing

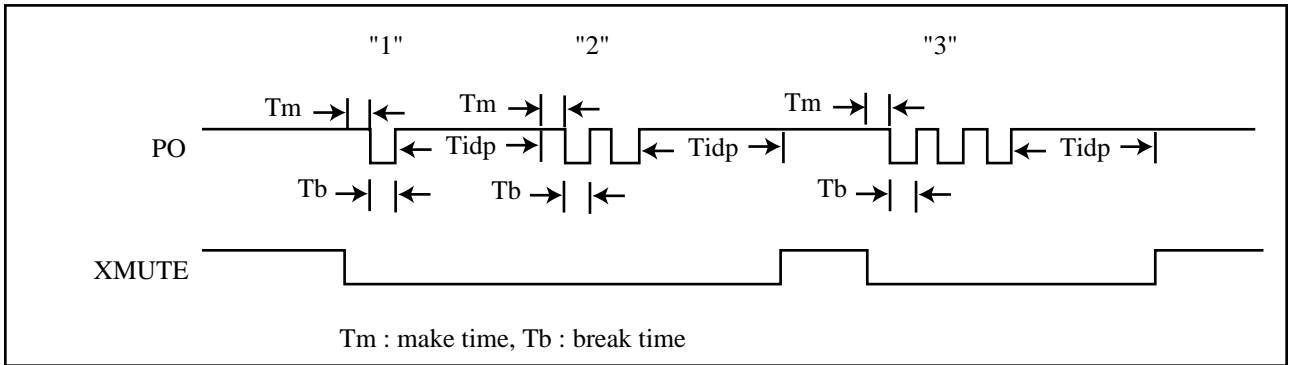

Redialing (One Key)

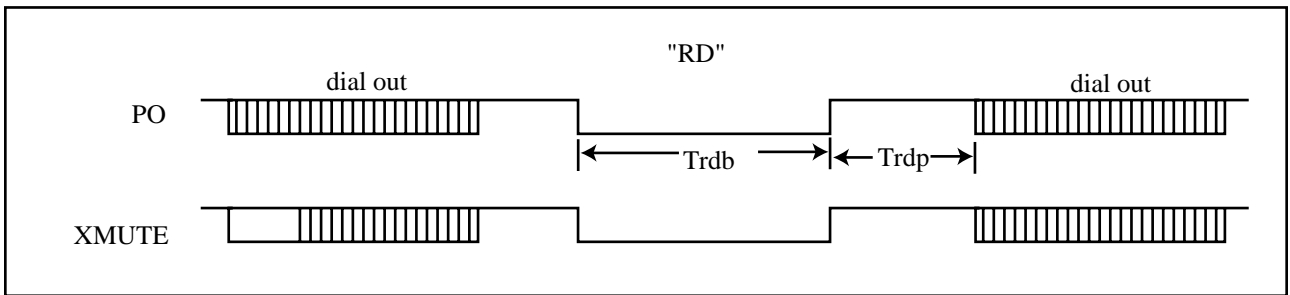

Flash operation

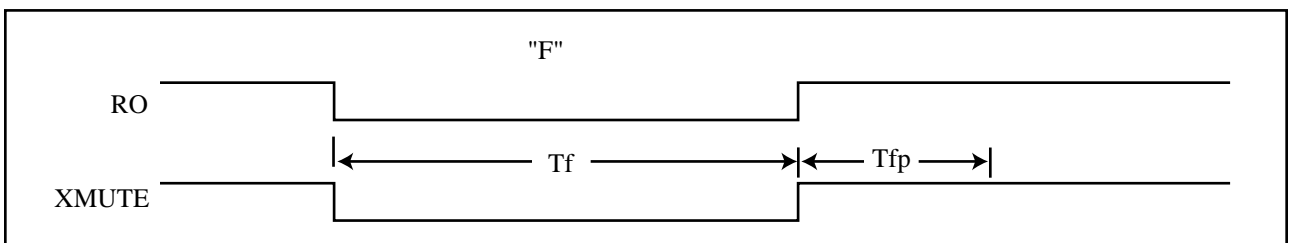

Preliminary

Mixed Dialing (P→T) and Pause operation

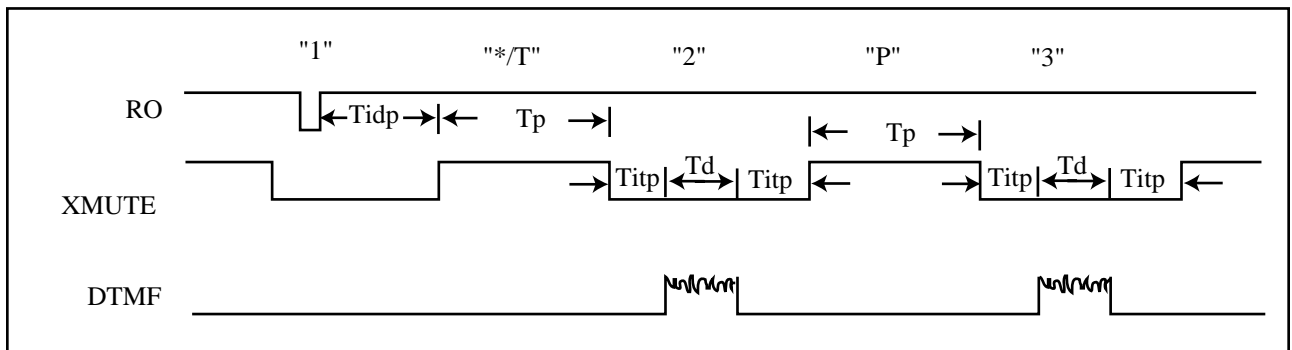

APPLICATION BLOCK DIAGRAM *Preliminary*

EM92100 (Handset unit)

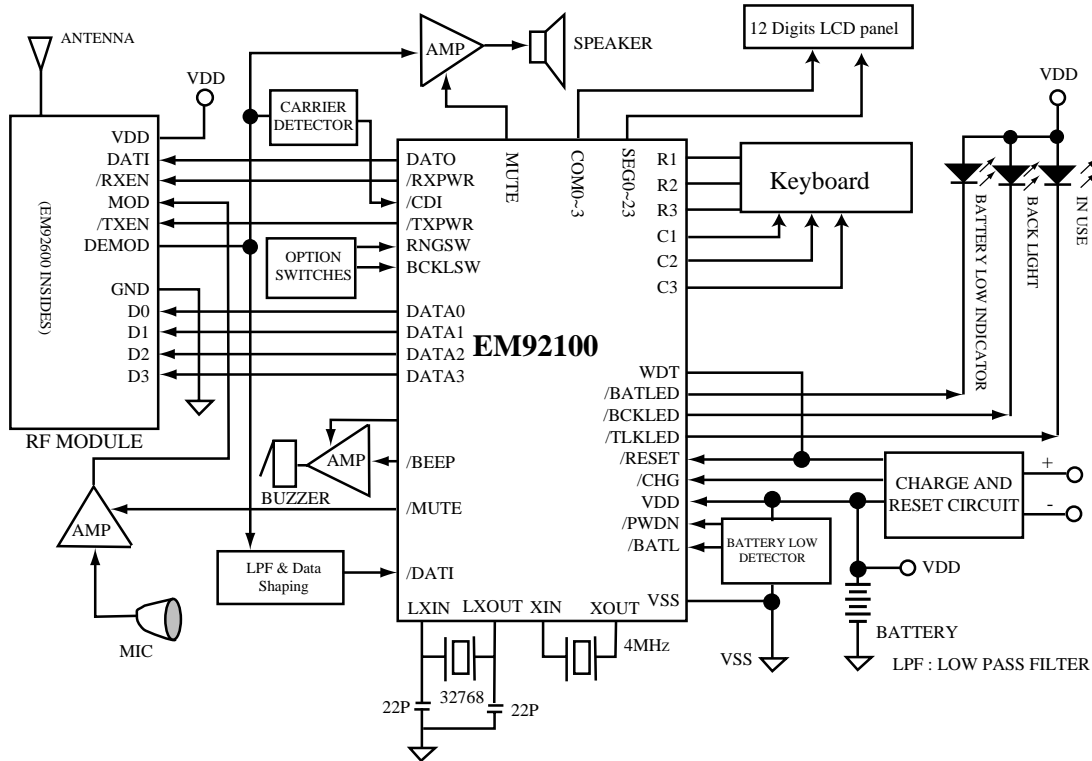

EM92101 (Base unit)

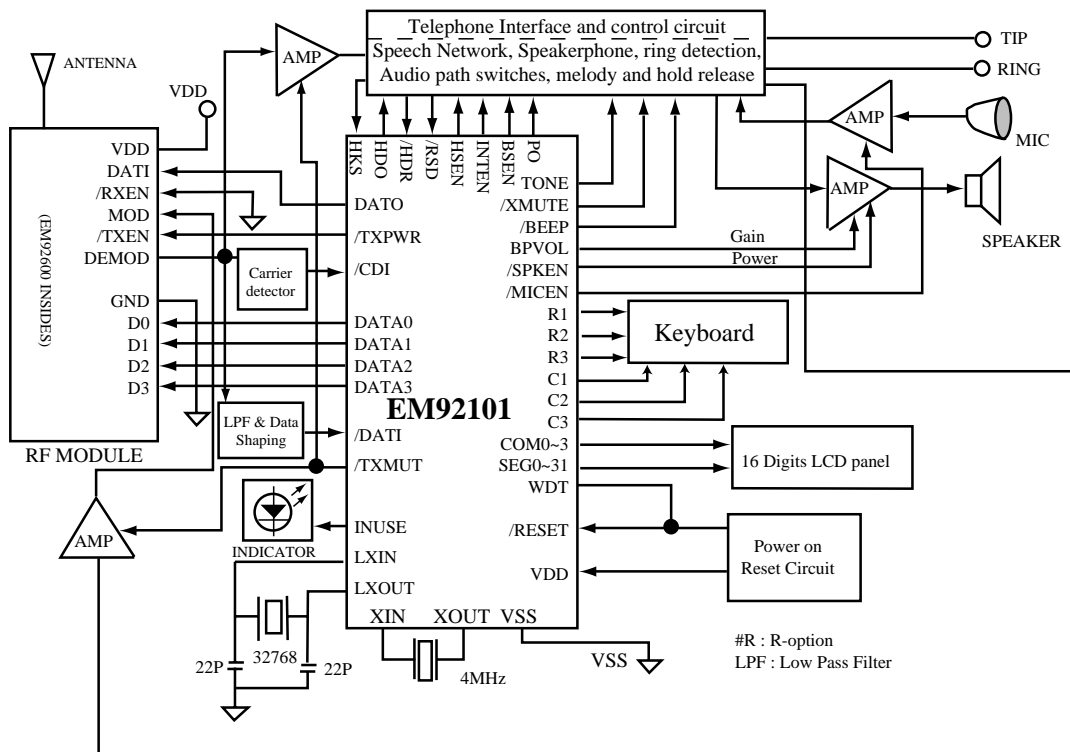

Preliminary

Base unit audio path control diagram

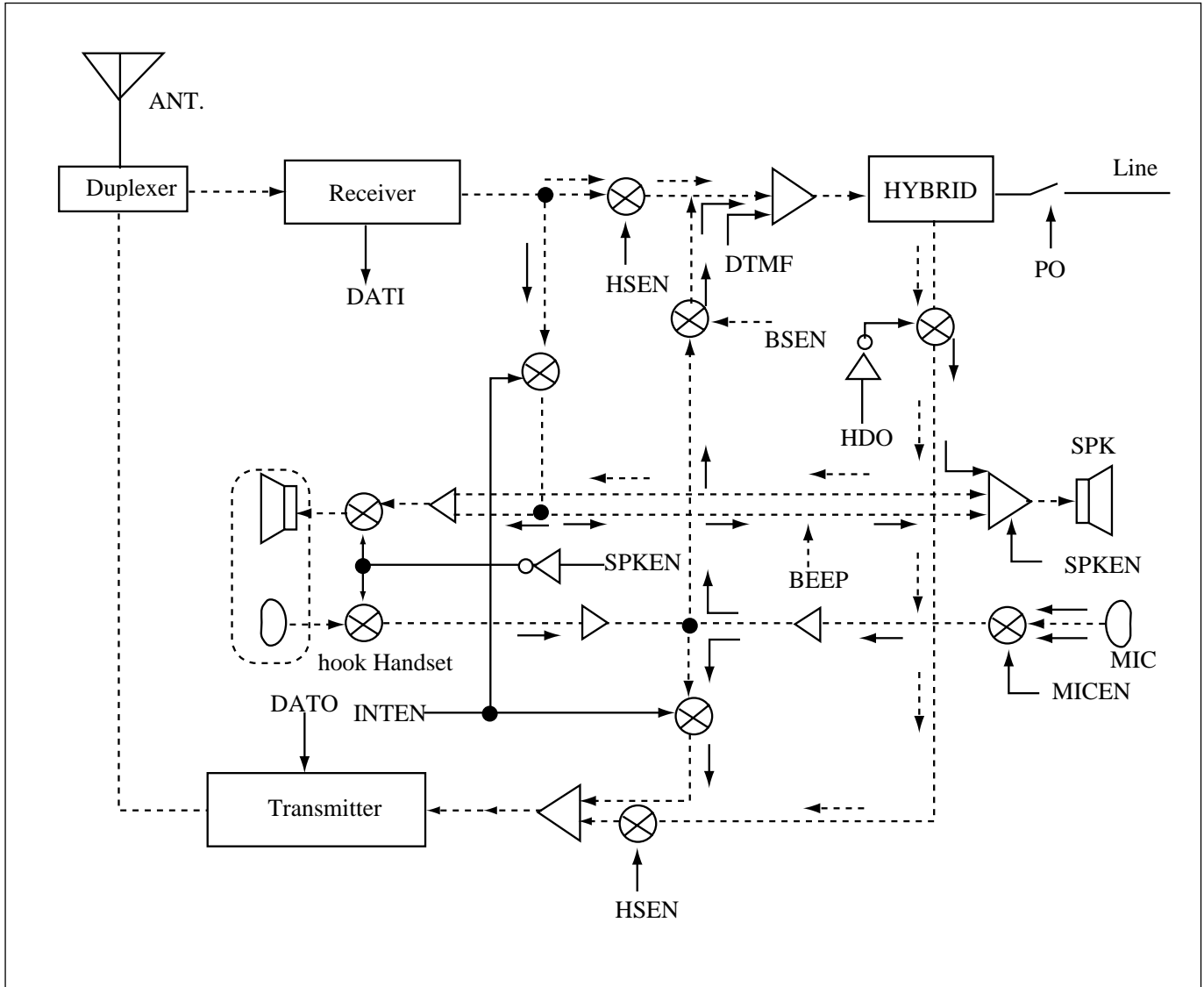

Preliminary

APPENDIX : EMC LCD Module and RF Module

1. RF Module (EMR011A/C, EMR012A/C)

- a. Low power, low cost, small size and high performance design.
- b. Built-in EM92600 serial dual PLL.
- c. 46/49 MHz and 45/48 MHz band available.
- d. Comander design for low noise, high voice quality.
- e. Include DATA waveform shaping fit the main controller data format.
- f. Built-in speaker and microphone amplifier.

Itme	Band (CH)	Comander	Suggestion model (Note)
EMR011A	46/49 (1/10)	---	Low cost, EM92002/3 cordless phone controller
EMR011C	45/48 (1/10)	---	Low cost, EM92002/3 cordless phone controller
EMR012A	46/49 (1/2/10)	√	EM92010/011, EM94014/15, HM94004B/5B
EMR012C	45/48 (1/2/10)	√	EM92010/011, EM94014/15, HM94004B/5B

All of the detail specifications are refered to EMR011/012 production specifications.

Preliminary

MECHANICAL DIMENSION

QFP 44

unit : inches

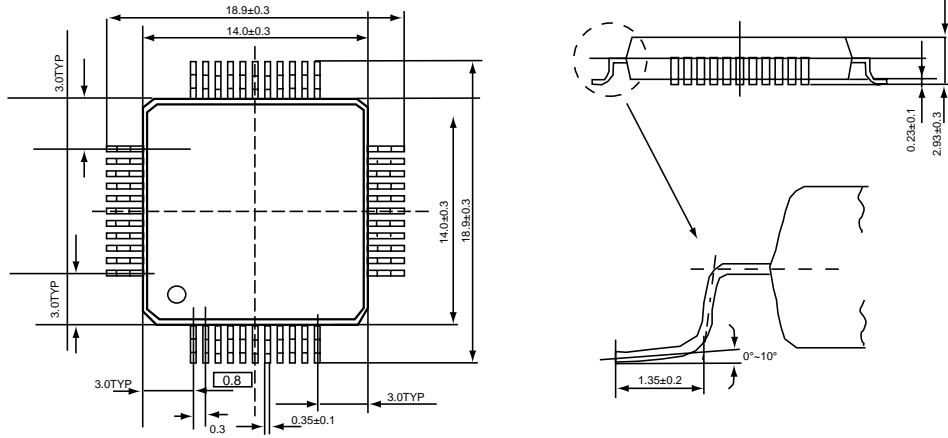

SDIP 42

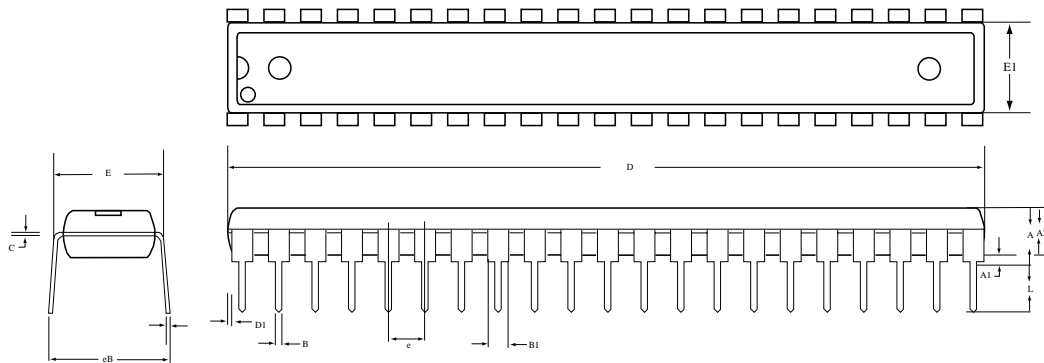

42 SDIP				
DIM	MILIMETERS		INCHES	
	MIN.	MAX.	MIN.	MAX.
A	-	5.08	-	0.200
A1	0.381	-	0.015	-
A2	3.937	4.191	0.155	0.165
B	0.356	0.559	0.014	0.022
B1	0.914	1.116	0.036	0.044
C	0.204	0.304	0.008	0.012
D	36.70	37.34	1.445	1.470
E1	13.84	14.10	0.545	0.555
e	1.727	1.829	0.068	0.072
eB	15.24	17.78	0.600	0.70
D1	0	0.127	0	0.005
L	2.921	3.429	0.115	0.135