

## Quad channel high side driver

### Features

Type	$R_{DS(on)}^{(1)}$	$I_{lim}$	$V_{CC}$
VNQ600AP-E	35 m $\Omega$	25 A	36 V

1. Per each channel

- DC short circuit current: 25 A
- CMOS compatible inputs
- Proportional load current sense
- Undervoltage and overvoltage shutdown
- Overvoltage clamp
- Thermal shutdown
- Current limitation
- Very low standby power dissipation
- Protection against: loss of ground and loss of  $V_{CC}$
- Reverse battery protection<sup>(a)</sup>
- In compliance with the 2002/95/EC european directive

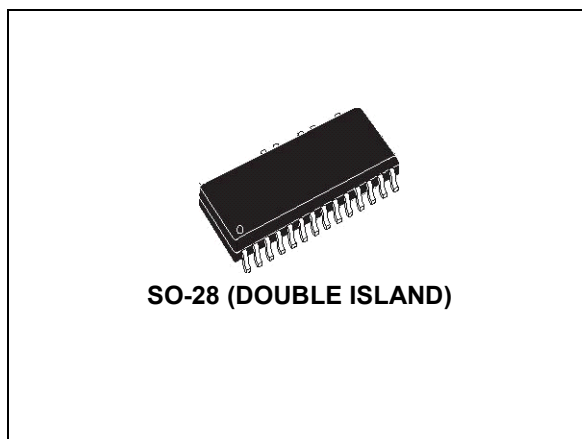

### Description

The VNQ600AP-E is a quad HSD formed by assembling two VND600-E chips in the same SO-28 package. The VND600-E is a monolithic device designed in STMicroelectronics VIPower M0-3 Technology. The VNQ600AP-E is intended for driving any type of multiple loads with one side connected to ground. This device has four independent channels and four analog sense outputs which deliver currents proportional to the outputs currents. Active current limitation combined with thermal shutdown and automatic restart protect the device against overload. Device automatically turns off in case of ground pin disconnection.

**Table 1. Device summary**

Package	Order codes	
	Tube	Tape and reel
SO-28	VNQ600AP-E	VNQ600APTR-E

a. See [Application schematic on page 14](#).

# Contents

<b>1</b>	<b>Block diagram and pin description</b> .....	<b>5</b>
<b>2</b>	<b>Electrical specifications</b> .....	<b>7</b>
2.1	Absolute maximum ratings .....	7
2.2	Thermal data .....	8
2.3	Electrical characteristics .....	8
<b>3</b>	<b>Application information</b> .....	<b>14</b>
3.1	GND protection network against reverse battery .....	14
3.2	Load dump protection .....	15
3.3	Microcontroller I/O protection .....	15
3.4	Electrical characteristics curves .....	17
3.5	Maximum demagnetization energy (VCC = 13.5V) .....	19
<b>4</b>	<b>Package and PCB thermal data</b> .....	<b>20</b>
4.1	SO-28 thermal data .....	20
<b>5</b>	<b>Package and packing information</b> .....	<b>23</b>
5.1	ECOPACK <sup>®</sup> packages .....	23
5.2	SO-28 packing information .....	24
<b>6</b>	<b>Revision history</b> .....	<b>25</b>

## List of tables

Table 1.	Device summary . . . . .	1
Table 2.	Suggested connections for unused and not connected pins . . . . .	6
Table 3.	Absolute maximum rating . . . . .	7
Table 4.	Thermal data (per island) . . . . .	8
Table 5.	Power . . . . .	8
Table 6.	Switching ( $V_{CC}=13\text{ V}$ ) . . . . .	9
Table 7.	$V_{CC}$ - output diode . . . . .	9
Table 8.	Logic input . . . . .	9
Table 9.	Protections . . . . .	9
Table 10.	Current sense ( $9\text{ V} < V_{CC} < 16\text{ V}$ ) (see <a href="#">Figure 7</a> ) . . . . .	10
Table 11.	Truth table. . . . .	10
Table 12.	Electrical transient requirements (part 1/3) . . . . .	11
Table 13.	Electrical transient requirements (part 2/3) . . . . .	11
Table 14.	Electrical transient requirements (part 3/3) . . . . .	11
Table 15.	Thermal calculation according to the PCB heatsink area . . . . .	20
Table 16.	Thermal parameter . . . . .	22
Table 17.	SO-28 mechanical data . . . . .	23
Table 18.	Document revision history . . . . .	25

## List of figures

Figure 1.	Block diagram . . . . .	5
Figure 2.	Configuration diagram (top view) . . . . .	6
Figure 3.	Current and voltage conventions . . . . .	7
Figure 4.	Switching characteristics (resistive load $R_L = 2.6 \Omega$ ). . . . .	12
Figure 5.	Waveforms (per each chip). . . . .	13
Figure 6.	Application schematic . . . . .	14
Figure 7.	IOUT/ISENSE versus IOUT . . . . .	16
Figure 8.	Off-state output current. . . . .	17
Figure 9.	High level input current. . . . .	17
Figure 10.	Input clamp voltage. . . . .	17
Figure 11.	Input high level . . . . .	17
Figure 12.	Input low level. . . . .	17
Figure 13.	Input hysteresis voltage . . . . .	17
Figure 14.	Overvoltage shutdown . . . . .	18
Figure 15.	ILIM vs Tcase . . . . .	18
Figure 16.	Turn-on voltage slope . . . . .	18
Figure 17.	Turn-off voltage slope . . . . .	18
Figure 18.	On-state resistance vs Tcase . . . . .	18
Figure 19.	On-state resistance vs VCC . . . . .	18
Figure 20.	Maximum turn-off current versus load inductance . . . . .	19
Figure 21.	Demagnetization . . . . .	19
Figure 22.	SO-28 PC board . . . . .	20
Figure 23.	Rthj-amb Vs PCB copper area in open box free air condition . . . . .	21
Figure 24.	Thermal impedance junction ambient single pulse . . . . .	21
Figure 25.	Thermal fitting model of a quad channel HSD in SO-28. . . . .	22
Figure 26.	SO-28 package dimensions . . . . .	23
Figure 27.	SO-28 tube shipment (no suffix) . . . . .	24
Figure 28.	SO-28 tape and reel shipment (suffix "TR") . . . . .	24

# 1 Block diagram and pin description

Figure 1. Block diagram

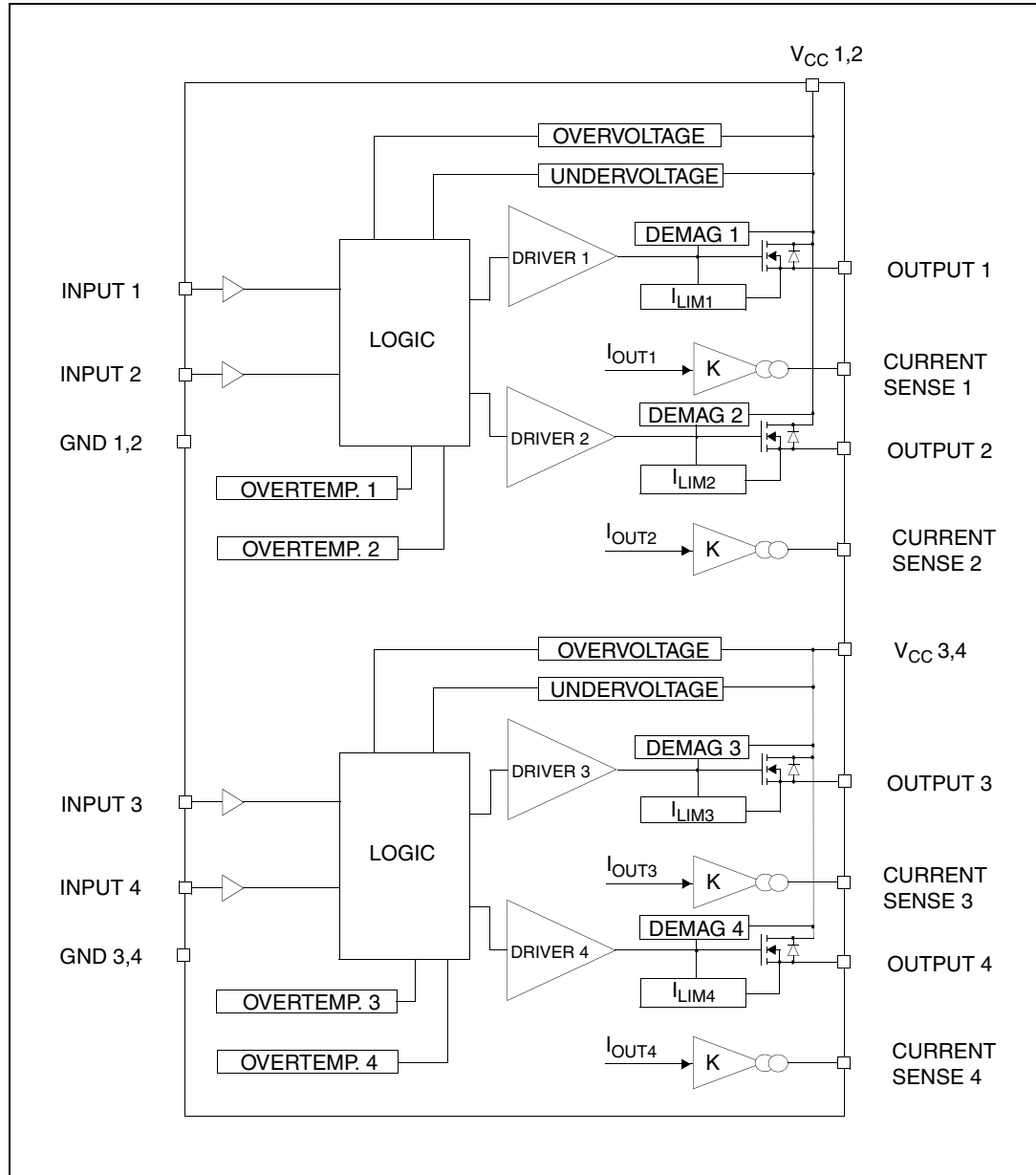

**Figure 2. Configuration diagram (top view)**

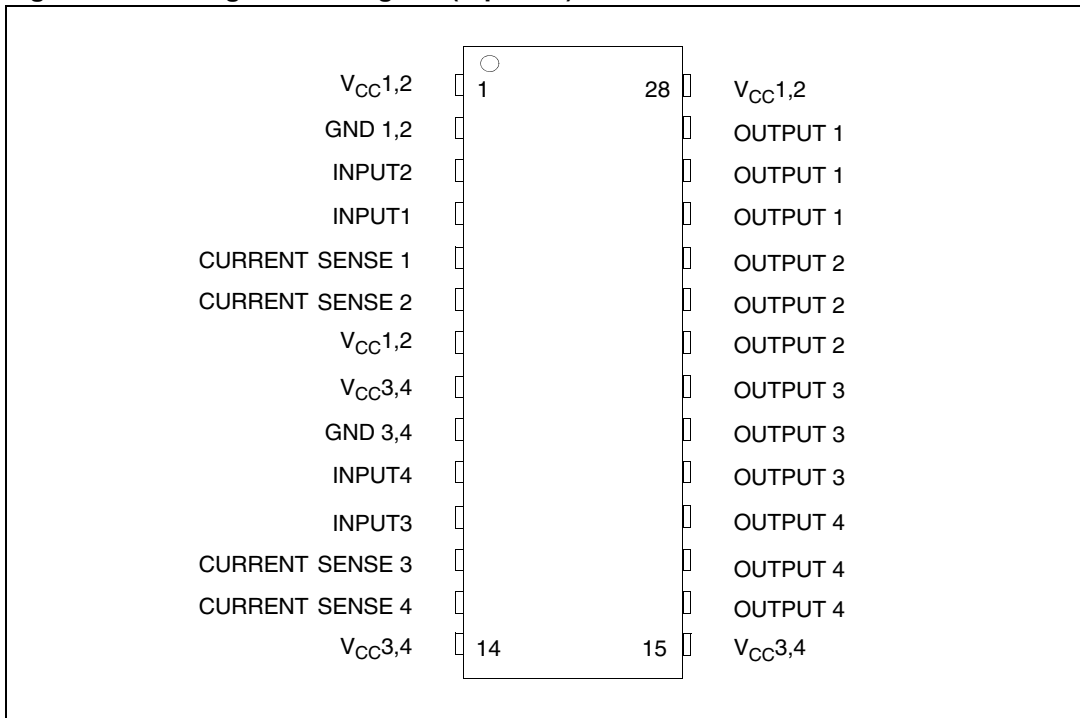
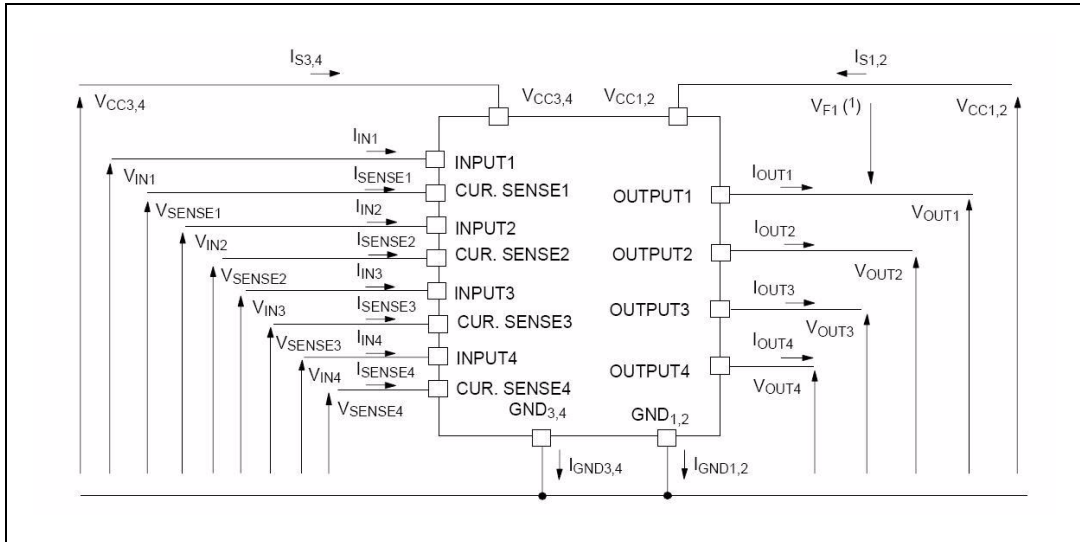

**Table 2. Suggested connections for unused and not connected pins**

Connection/pin	Current sense	N.C.	Output	Input
Floating	Not allowed	X	X	X
To ground	Through 1 kΩ resistor	X	Not allowed	Through 10 kΩ resistor

## 2 Electrical specifications

Figure 3. Current and voltage conventions



1.  $V_{Fn} = V_{CCn} - V_{OUTn}$  during reverse battery condition

### 2.1 Absolute maximum ratings

Table 3. Absolute maximum rating

Symbol	Parameter	Value	Unit
$V_{CC}$	Supply voltage (continuous)	41	V
$-V_{CC}$	Reverse supply voltage (continuous)	-0.3	V
$I_{OUT}$	Output current (continuous), for each channel	15	A
$I_R$	Reverse output current (continuous), for each channel	-15	A
$I_{IN}$	Input current	+/- 10	mA
$V_{CSENSE}$	Current sense maximum voltage	-3 +15	V V
$I_{GND}$	Ground current at $T_{pins} \leq 25\text{ }^\circ\text{C}$ (continuous)	-200	mA
$V_{ESD}$	Electrostatic discharge (Human Body Model: $R=1.5\text{ K}\Omega$ ; $C=100\text{ pF}$ ) - Input - Current Sense - Output - $V_{CC}$	4000 2000 5000 5000	V V V V
$E_{MAX}$	Maximum switching energy ( $L=0.11\text{ mH}$ ; $R_L=0\text{ }\Omega$ ; $V_{bat}=13.5\text{ V}$ ; $T_{jstart}=150\text{ }^\circ\text{C}$ ; $I_L=40\text{ A}$ )	126	mJ
$P_{tot}$	Power dissipation (per island) at $T_{lead}=25\text{ }^\circ\text{C}$	6.25	W

**Table 3. Absolute maximum rating (continued)**

Symbol	Parameter	Value	Unit
$T_j$	Junction operating temperature	Internally limited	°C
$T_{stg}$	Storage temperature	-55 to 150	°C

## 2.2 Thermal data

**Table 4. Thermal data (per island)**

Symbol	Parameter	Value		Unit
$R_{thj-lead}$	Thermal resistance Junction-lead (max)	15		°C/W
$R_{thj-amb}$	Thermal resistance Junction-ambient (one chip on max)	60 <sup>(1)</sup>	44 <sup>(2)</sup>	°C/W
$R_{thj-amb}$	Thermal Resistance Junction-ambient (two chips on max)	46 <sup>(1)</sup>	31 <sup>(2)</sup>	°C/W

- When mounted on a standard single-sided FR-4 board with 0.5 cm<sup>2</sup> of Cu (at least 35 μm thick) connected to all V<sub>CC</sub> pins. Horizontal mounting and no artificial air flow.
- When mounted on a standard single-sided FR-4 board with 6 cm<sup>2</sup> of Cu (at least 35 μm thick) connected to all V<sub>CC</sub> pins. Horizontal mounting and no artificial air flow.

## 2.3 Electrical characteristics

Values specified in this section are for 8 V < V<sub>CC</sub> < 36 V; -40 °C < T<sub>j</sub> < 150 °C, unless otherwise specified.

**Table 5. Power**

Symbol	Parameter	Test conditions	Min.	Typ.	Max.	Unit
V <sub>CC</sub> <sup>(1)</sup>	Operating supply voltage		5.5	13	36	V
V <sub>USD</sub> <sup>(1)</sup>	Undervoltage shutdown		3	4	5.5	V
V <sub>OV</sub> <sup>(1)</sup>	Overvoltage shutdown		36	-	-	V
R <sub>ON</sub>	On-state resistance	I <sub>OUT</sub> 1,2,3,4=5 A; T <sub>j</sub> =25 °C I <sub>OUT</sub> 1,2,3,4=5 A; T <sub>j</sub> =150 °C I <sub>OUT</sub> 1,2,3,4=3 A; V <sub>CC</sub> =6 V	-	-	35 70 120	mΩ mΩ mΩ
V <sub>clamp</sub>	Clamp voltage	I <sub>CC</sub> =20 mA <sup>(2)</sup>	41	48	55	V
I <sub>S</sub> <sup>(1)</sup>	Supply current	Off-state; V <sub>CC</sub> =13 V; V <sub>IN</sub> =V <sub>OUT</sub> =V <sub>SENSE</sub> =0 V Off-state; V <sub>CC</sub> =13 V; V <sub>IN</sub> =V <sub>OUT</sub> =V <sub>SENSE</sub> =0V; T <sub>j</sub> =25 °C On-state; V <sub>CC</sub> =13 V; V <sub>IN</sub> =5 V; I <sub>OUT</sub> =0 A; R <sub>SENSE</sub> =3.9 KΩ; V <sub>SENSE</sub> =0 V	-	12 12	40 25 6	μA μA mA
I <sub>L(off1)</sub>	Off-state output current	V <sub>IN</sub> =V <sub>OUT</sub> =V <sub>SENSE</sub> =0V	0	-	50	μA



Table 5. Power (continued)

Symbol	Parameter	Test conditions	Min.	Typ.	Max.	Unit
$I_{L(off3)}$	Off-state output current	$V_{IN}=V_{OUT}=V_{SENSE}=0$ V; $V_{CC}=13$ V; $T_j=125$ °C	-	-	5	$\mu$ A
$I_{L(off4)}$	Off-state output current	$V_{IN}=V_{OUT}=V_{SENSE}=0$ V; $V_{CC}=13$ V; $T_j=25$ °C	-	-	3	$\mu$ A

1. Per island
2.  $V_{clamp}$  and  $V_{OV}$  are correlated. Typical difference is 5 V.

Table 6. Switching ( $V_{CC}=13$  V)

Symbol	Parameter	Test conditions	Min.	Typ.	Max.	Unit
$t_{D(on)}$	Turn-on delay time	$R_L=2.6$ $\Omega$ channels 1,2,3,4 (see <a href="#">Figure 4</a> )	-	40	-	$\mu$ s
$t_{D(off)}$	Turn-off delay time	$R_L=2.6$ $\Omega$ channels 1,2,3,4 (see <a href="#">Figure 4</a> )	-	40	-	$\mu$ s
$(dV_{OUT}/dt)_{on}$	Turn-on voltage slope	$R_L=2.6$ $\Omega$ channels 1,2,3,4 (see <a href="#">Figure 4</a> )	-	See relative diagram	-	V/ $\mu$ s
$(dV_{OUT}/dt)_{off}$	Turn-off voltage slope	$R_L=2.6$ $\Omega$ channels 1,2,3,4 (see <a href="#">Figure 4</a> )	-	See relative diagram	-	V/ $\mu$ s

Table 7.  $V_{CC}$  - output diode

Symbol	Parameter	Test conditions	Min.	Typ.	Max.	Unit
$V_F$	Forward on voltage	$-I_{OUT}=2.3$ A; $T_j=150$ °C	-	-	0.6	V

Table 8. Logic input

Symbol	Parameter	Test conditions	Min.	Typ.	Max.	Unit
$V_{IL}$	Low level input voltage		-	-	1.25	V
$V_{IH}$	High level input voltage		3.25	-	-	V
$V_{I(hyst)}$	Input hysteresis voltage		0.5	-	-	V
$I_{iL}$	Low level input current	$V_{IN}=1.25$ V	20	65	-	$\mu$ A
$I_{iH}$	High level input current	$V_{IN}=3.25$ V	-	75	110	$\mu$ A
$V_{ICL}$	Input clamp voltage	$I_{IN}=1$ mA $I_{IN}=-1$ mA	6	6.8 -0.7	8	V V

Table 9. Protections<sup>(1)</sup>

Symbol	Parameter	Test conditions	Min.	Typ.	Max.	Unit
$I_{lim}$	DC short circuit current	$V_{CC}=13$ V $5.5$ V < $V_{CC}$ < 36 V	25	40	70 70	A A
$T_{TSD}$	Thermal shutdown temperature		150	175	200	°C

**Table 9. Protections<sup>(1)</sup> (continued)**

Symbol	Parameter	Test conditions	Min.	Typ.	Max.	Unit
$T_R$	Thermal reset temperature		135	-	-	°C
$T_{hyst}$	Thermal hysteresis		7	15	-	°C
$V_{demag}$	Turn-off output voltage clamp	$I_{OUT}=2\text{ A}$ ; $L=6\text{ mH}$	$V_{CC}-41$	$V_{CC}-48$	$V_{CC}-55$	V
$V_{ON}$	Output voltage drop limitation	$I_{OUT}=0.5\text{ A}$ ; $T_j = -40\text{ °C} \dots +150\text{ °C}$	-	50	-	mV

1. To ensure long term reliability under heavy overload or short circuit conditions, protection and related diagnostic signals must be used together with a proper software strategy. If the device is subjected to abnormal conditions, this software must limit the duration and number of activation cycles.

**Table 10. Current sense (9 V <  $V_{CC}$  < 16 V) (see Figure 7)**

Symbol	Parameter	Test conditions	Min.	Typ.	Max.	Unit
K1	$I_{OUT}/I_{SENSE}$	$I_{OUT1,2}=0.35\text{ A}$ ; $V_{SENSE}=0.5\text{ V}$ ; $T_j = -40\text{ °C} \dots +150\text{ °C}$	3100	4150	5560	
K2	$I_{OUT}/I_{SENSE}$	$I_{OUT}=2\text{ A}$ ; $V_{SENSE}=2.5\text{ V}$ ; $T_j = -40\text{ °C}$ $T_j = 25\text{ °C} \dots +150\text{ °C}$	3750 4000	4600 4600	5700 5400	
K3	$I_{OUT}/I_{SENSE}$	$I_{OUT}=4\text{ A}$ ; $V_{SENSE}=4\text{ V}$ ; $T_j = -40\text{ °C}$ $T_j = 25\text{ °C} \dots +150\text{ °C}$	4000 4100	4500 4500	5200 5150	
$V_{SENSE1,2}$	Max analog sense output voltage	$V_{CC}=5.5\text{ V}$ ; $I_{OUT1,2}=2\text{ A}$ ; $R_{SENSE}=10\text{ K}\Omega$	2			V
		$V_{CC}>8\text{ V}$ ; $I_{OUT1,2}=4\text{ A}$ ; $R_{SENSE}=10\text{ K}\Omega$	4	-	-	V
$V_{SENSEH}$	Analog sense output voltage in over temperature condition	$V_{CC}=13\text{ V}$ ; $R_{SENSE}=3.9\text{ K}\Omega$	-	5	-	V
$R_{VSENSEH}$	Analog sense output impedance in over temperature condition	$V_{CC}=13\text{ V}$ ; $T_j > T_{TSD}$ ; All channels open	-	400	-	$\Omega$
$t_{DSENSE}$	Current sense delay response	to 90% $I_{SENSE}$ <sup>(1)</sup>	-	-	500	$\mu\text{s}$

1. Current sense signal delay after positive input slope.

**Table 11. Truth table**

Conditions	Input	Output	Sense
Normal operation	L	L	0
	H	H	Nominal
Over temperature	L	L	0
	H	L	$V_{SENSEH}$
Undervoltage	L	L	0
	H	L	0

Table 11. Truth table (continued)

Conditions	Input	Output	Sense
Overvoltage	L	L	0
	H	L	0
Short circuit to GND	L	L	0
	H	L	$(T_j < T_{TSD}) 0$
	H	L	$(T_j > T_{TSD}) V_{SENSEH}$
Short circuit to $V_{CC}$	L	H	0
	H	H	< Nominal
Negative output voltage clamp	L	L	0

Table 12. Electrical transient requirements (part 1/3)

ISO T/R 7637/1 test pulse	Test level				Delays and impedance
	I	II	III	IV	
1	-25 V	-50 V	-75 V	-100 V	2 ms, 10 $\Omega$
2	+25 V	+50 V	+75 V	+100 V	0.2 ms, 10 $\Omega$
3a	-25 V	-50 V	-100 V	-150 V	0.1 $\mu$ s, 50 $\Omega$
3b	+25 V	+50 V	+75 V	+100 V	0.1 $\mu$ s, 50 $\Omega$
4	-4 V	-5 V	-6 V	-7 V	100 ms, 0.01 $\Omega$
5	+26.5 V	+46.5 V	+66.5 V	+86.5 V	400 ms, 2 $\Omega$

Table 13. Electrical transient requirements (part 2/3)

ISO T/R 7637/1 test pulse	Test levels result			
	I	II	III	IV
1	C	C	C	C
2	C	C	C	C
3a	C	C	C	C
3b	C	C	C	C
4	C	C	C	C
5	C	E	E	E

Table 14. Electrical transient requirements (part 3/3)

Class	Contents
C	All functions of the device are performed as designed after exposure to disturbance.
E	One or more functions of the device is not performed as designed after exposure and cannot be returned to proper operation without replacing the device.

Figure 4. Switching characteristics (resistive load  $R_L = 2.6 \Omega$ )

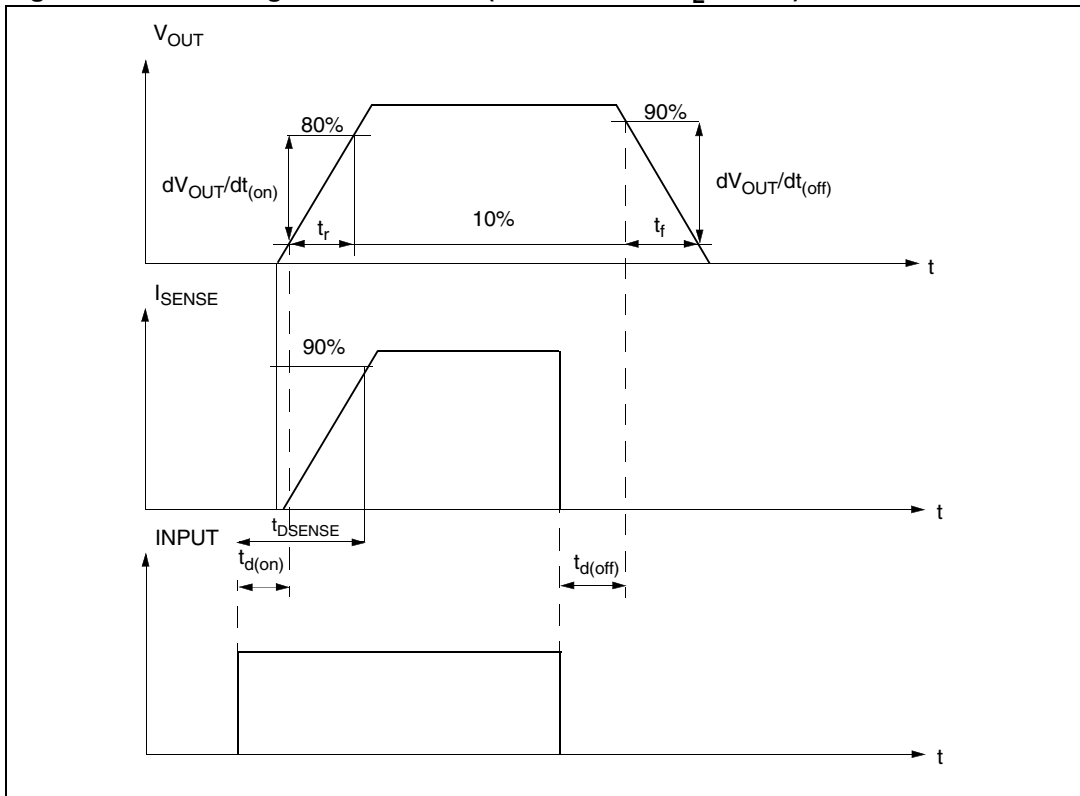
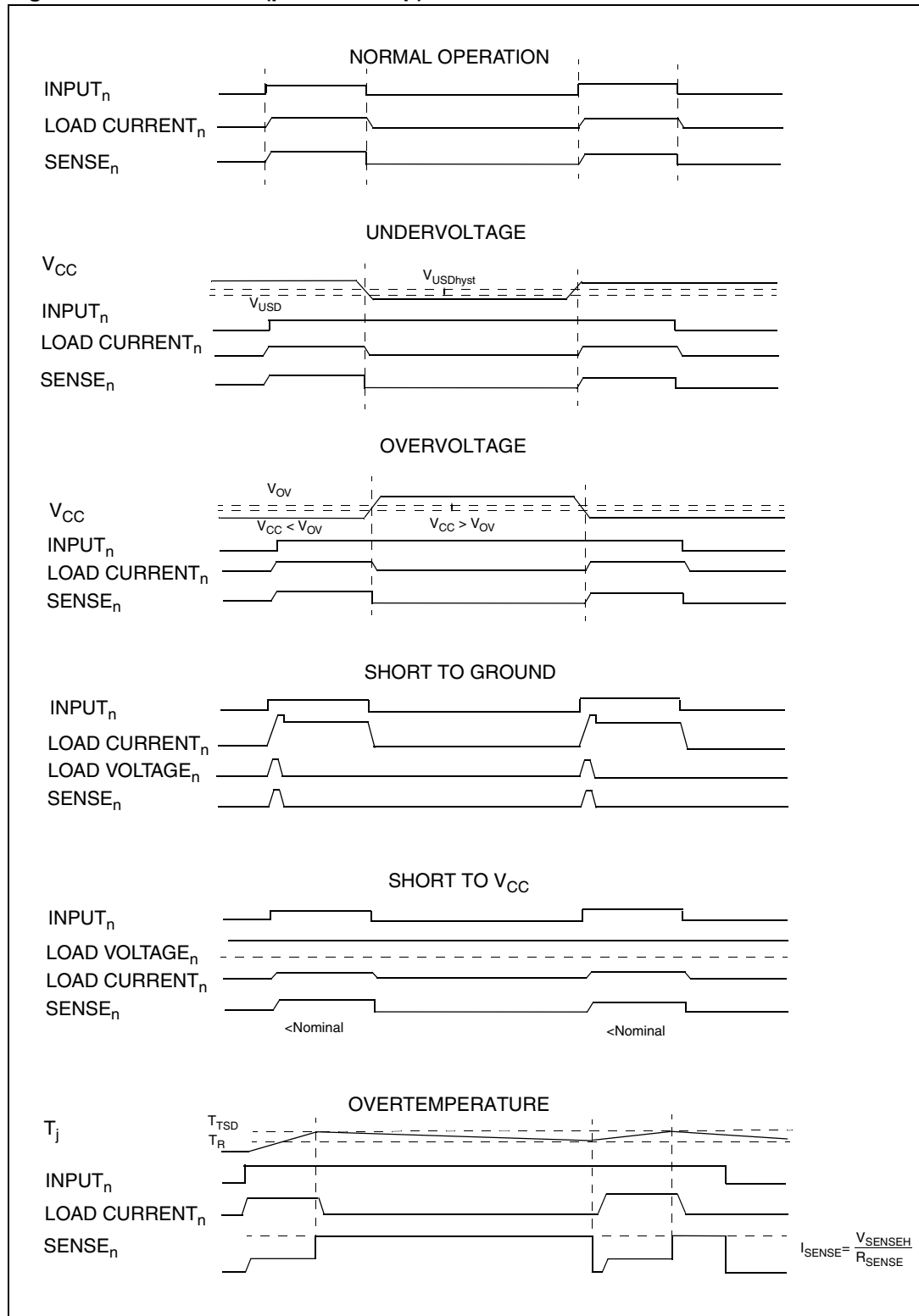
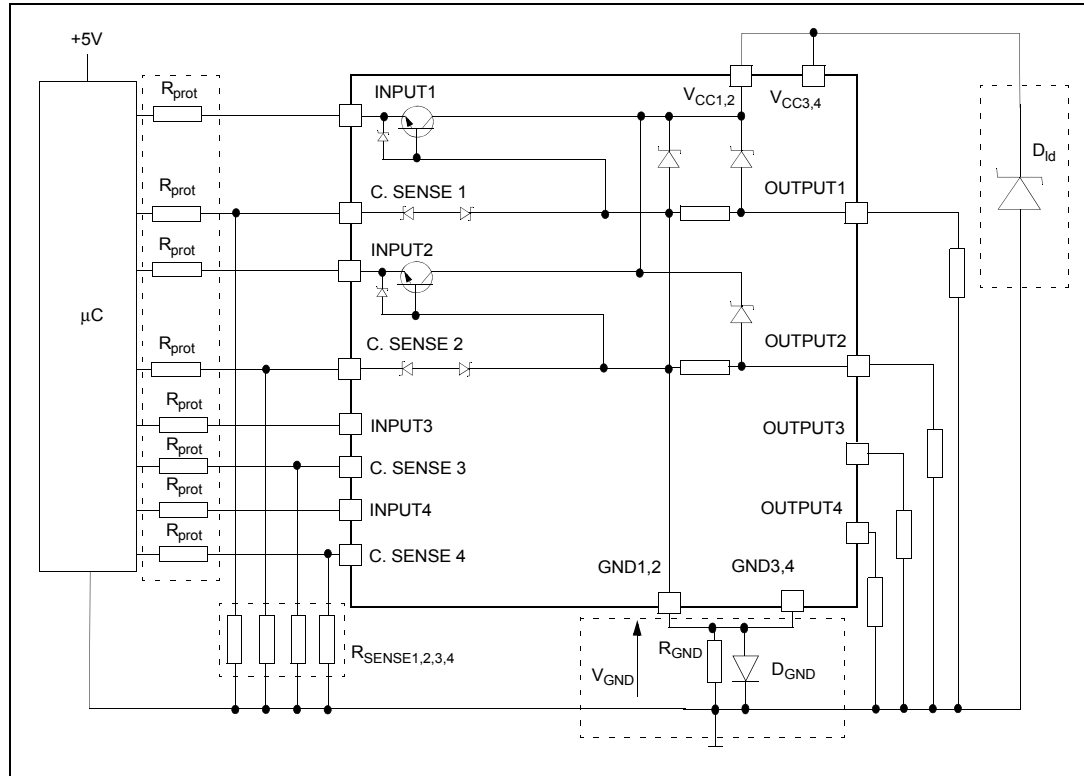

Figure 5. Waveforms (per each chip)



### 3 Application information

Figure 6. Application schematic



Note: Channels 3 and 4 have the same internal circuit as channel 1 and 2

#### 3.1 GND protection network against reverse battery

This section provides two solutions for implementing a ground protection network against reverse battery.

Solution 1: Resistor in the ground line ( $R_{GND}$  only). This can be used with any type of load. The following is an indication on how to dimension the  $R_{GND}$  resistor.

1.  $R_{GND} \leq 600 \text{ mV} / 2(I_{S(on)max})$
2.  $R_{GND} \geq (-V_{CC}) / (-I_{GND})$

where  $-I_{GND}$  is the DC reverse ground pin current and can be found in the absolute maximum rating section of the device’s datasheet.

Power dissipation in  $R_{GND}$  (when  $V_{CC} < 0$ : during reverse battery situations) is:

$$P_D = (-V_{CC})^2 / R_{GND}$$

This resistor can be shared amongst several different HSD. Please note that the value of this resistor should be calculated with formula (1) where  $I_{S(on)max}$  becomes the sum of the maximum on-state currents of the different devices.

Please note that if the microprocessor ground is not common with the device ground then the  $R_{GND}$  will produce a shift ( $I_{S(on)max} * R_{GND}$ ) in the input thresholds and the status output

values. This shift will vary depending on how many devices are ON in the case of several high side drivers sharing the same  $R_{GND}$ .

If the calculated power dissipation leads to a large resistor or several devices have to share the same resistor then the ST suggests to utilize Solution 2 (see below).

Solution 2: A diode ( $D_{GND}$ ) in the ground line. A resistor ( $R_{GND}=1\text{ k}\Omega$ ) should be inserted in parallel to  $D_{GND}$  if the device will be driving an inductive load.

This small signal diode can be safely shared amongst several different HSD. Also in this case, the presence of the ground network will produce a shift ( $\cong 600\text{mV}$ ) in the input threshold and the status output values if the microprocessor ground is not common with the device ground. This shift will not vary if more than one HSD shares the same diode/resistor network.

Series resistor in input line is also required to prevent that, during battery voltage transient, the current exceeds the absolute maximum rating.

Safest configuration for unused input pin is to leave it unconnected, while unused sense pin has to be connected to ground pin.

## 3.2 Load dump protection

$D_{ld}$  is necessary (voltage transient suppressor) if the load dump peak voltage exceeds the  $V_{CC}$  maximum DC rating. The same applies if the device is subject to transients on the  $V_{CC}$  line that are greater than those shown in the ISO T/R 7637/1 table.

## 3.3 Microcontroller I/O protection

If a ground protection network is used and negative transients are present on the  $V_{CC}$  line, the control pins will be pulled negative. ST suggests to insert a resistor ( $R_{prot}$ ) in line to prevent the  $\mu\text{C}$  I/O pins from latching up.

The value of these resistors is a compromise between the leakage current of  $\mu\text{C}$  and the current required by the HSD I/Os (Input levels compatibility) with the latch-up limit of microcontroller I/Os:

$$-V_{CCpeak}/I_{latchup} \leq R_{prot} \leq (V_{OH\mu C} - V_{IH} - V_{GND}) / I_{IHmax}$$

### Example

For the following conditions:

$$V_{CCpeak} = -100\text{ V}$$

$$I_{latchup} \geq 20\text{ mA}$$

$$V_{OH\mu C} \geq 4.5\text{ V}$$

$$5\text{ k}\Omega \leq R_{prot} \leq 65\text{ k}\Omega$$

Recommended values are:

$$R_{prot} = 5\text{ k}\Omega$$

Figure 7.  $I_{OUT}/I_{SENSE}$  versus  $I_{OUT}$

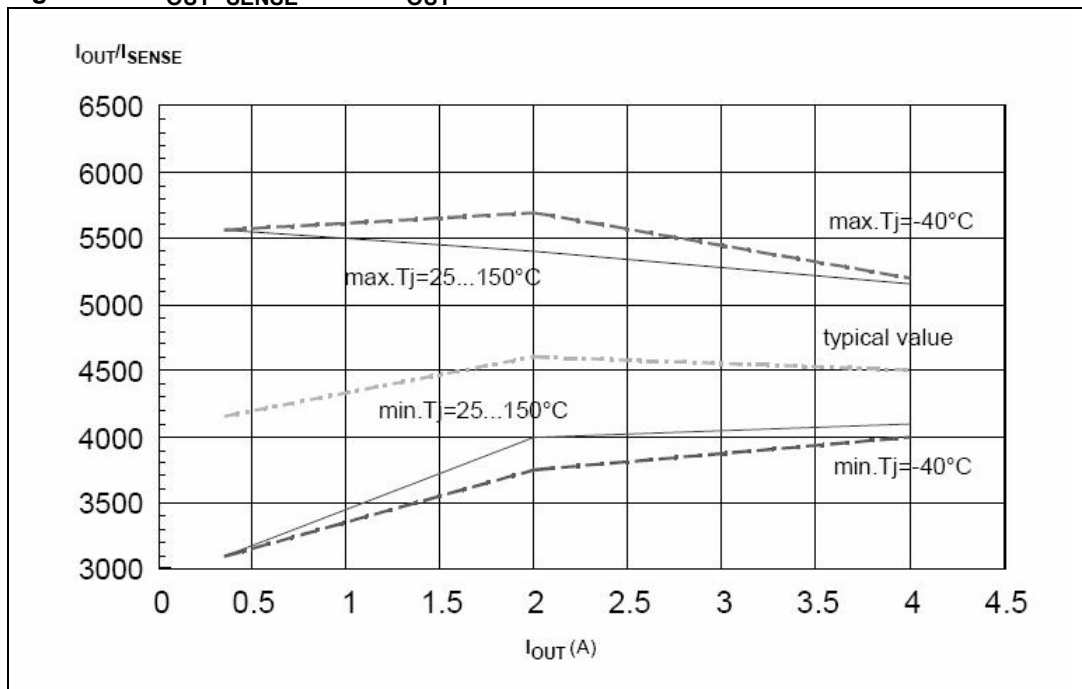



### 3.4 Electrical characteristics curves

**Figure 8. Off-state output current**

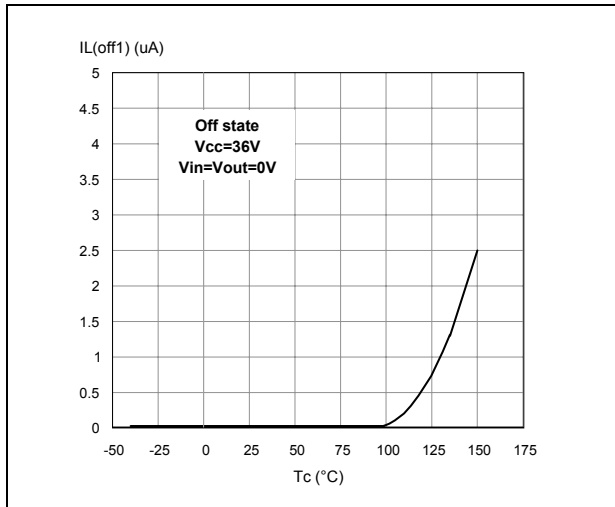

**Figure 9. High level input current**

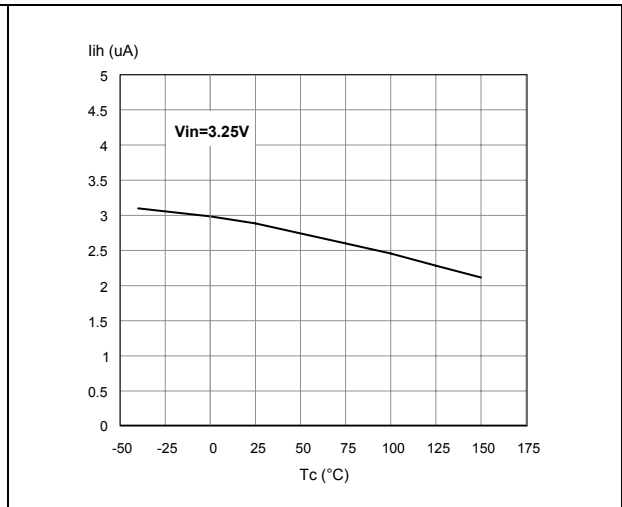

**Figure 10. Input clamp voltage**

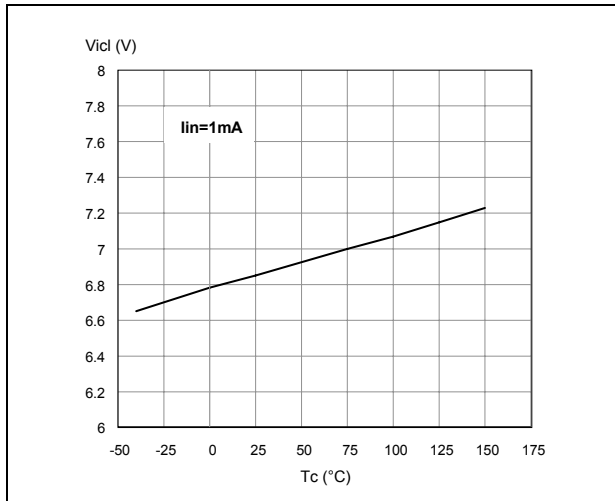

**Figure 11. Input high level**

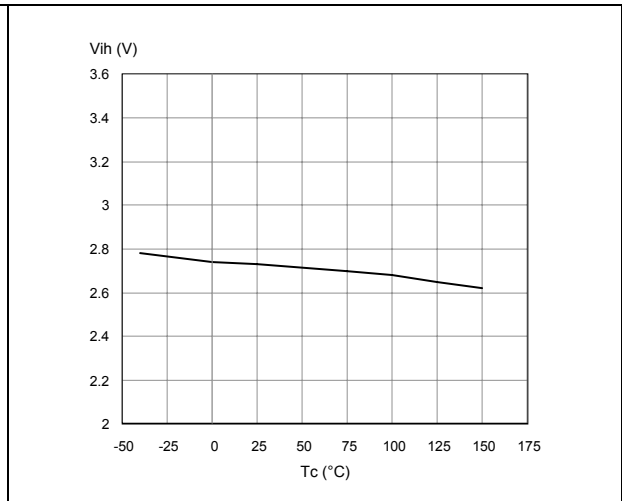

**Figure 12. Input low level**

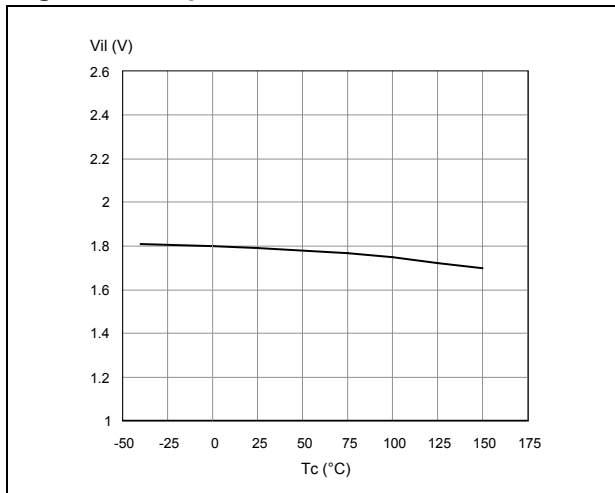

**Figure 13. Input hysteresis voltage**

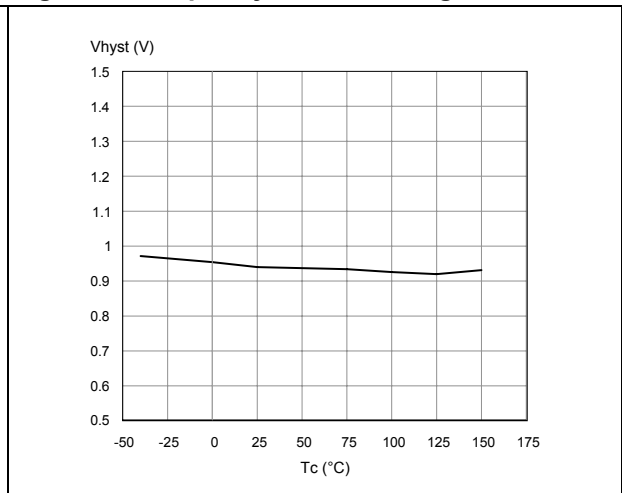

Figure 14. Overvoltage shutdown

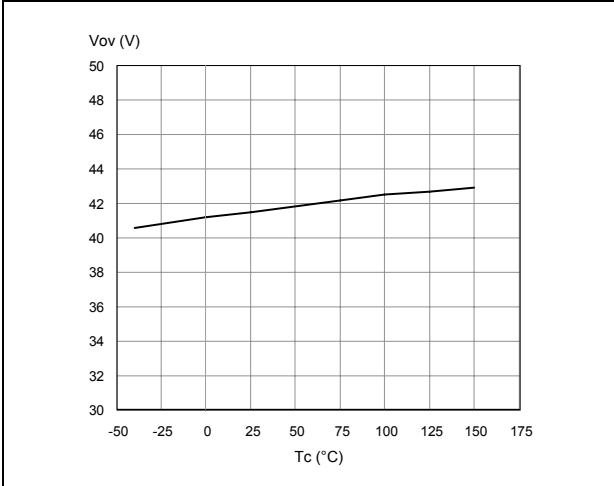

Figure 15. I<sub>LIM</sub> vs T<sub>case</sub>

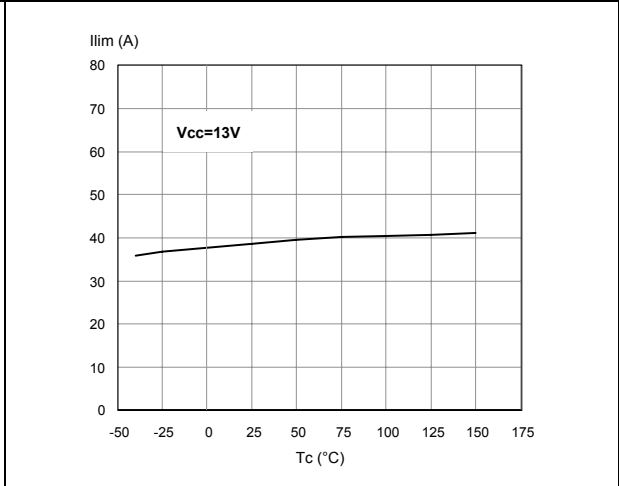

Figure 16. Turn-on voltage slope

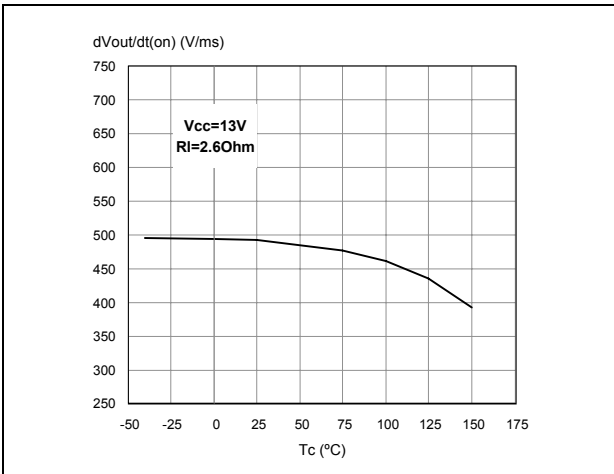

Figure 17. Turn-off voltage slope

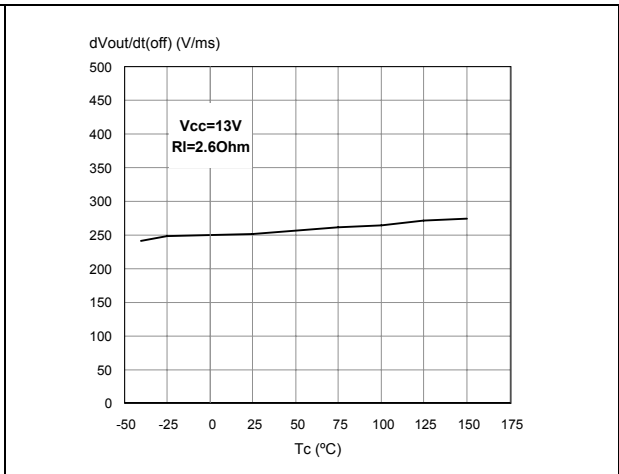

Figure 18. On-state resistance vs T<sub>case</sub>

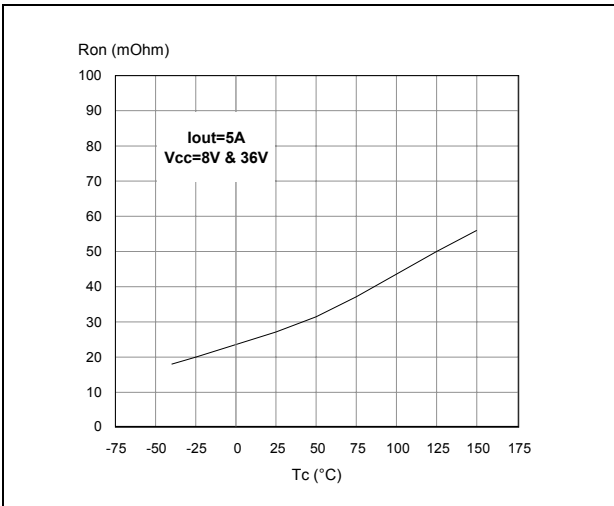
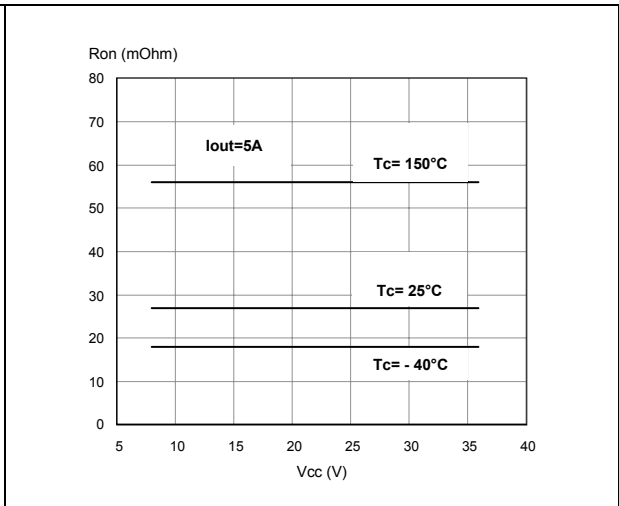
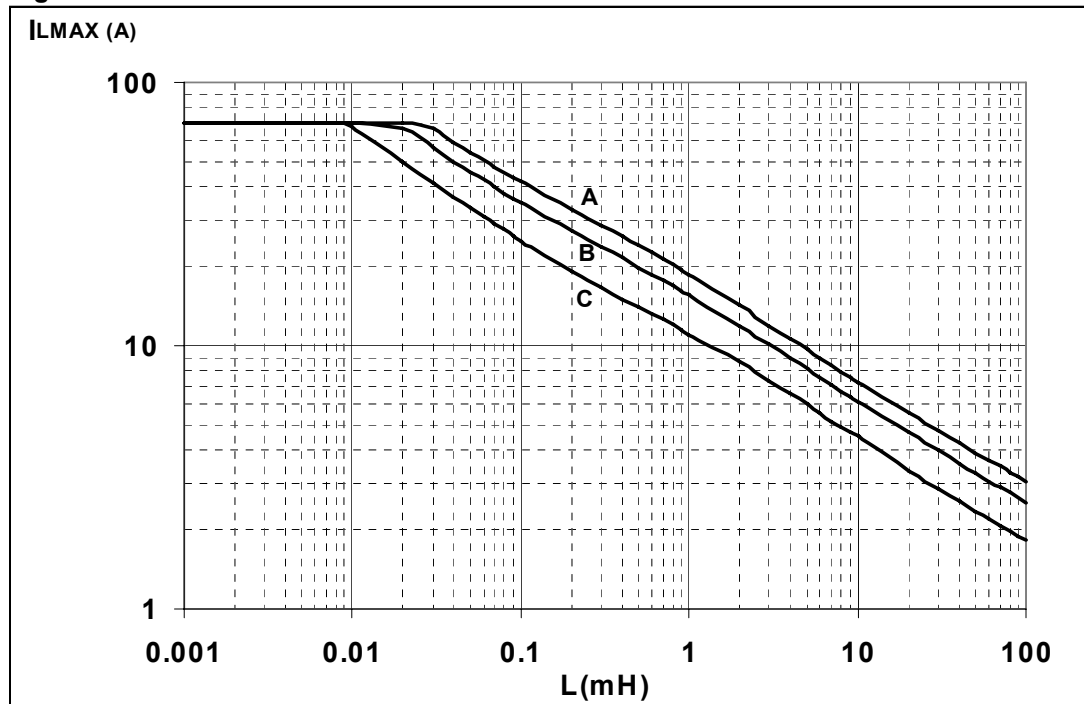

Figure 19. On-state resistance vs V<sub>CC</sub>



### 3.5 Maximum demagnetization energy (V<sub>CC</sub> = 13.5V)

Figure 20. Maximum turn-off current versus load inductance



Legend:

A = Single Pulse at T<sub>Jstart</sub>=150 °C

B = Repetitive pulse at T<sub>Jstart</sub>=100 °C

C = Repetitive Pulse at T<sub>Jstart</sub>=125 °C

Conditions:

V<sub>CC</sub>=13.5 V

Values are generated with R<sub>L</sub>=0 Ω

In case of repetitive pulses, T<sub>Jstart</sub> (at beginning of each demagnetization) of every pulse must not exceed the temperature specified above for curves B and C.

Figure 21. Demagnetization

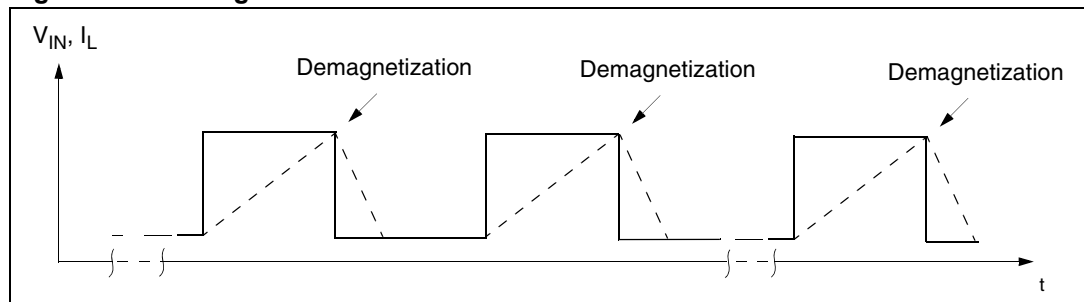

## 4 Package and PCB thermal data

### 4.1 SO-28 thermal data

Figure 22. SO-28 PC board

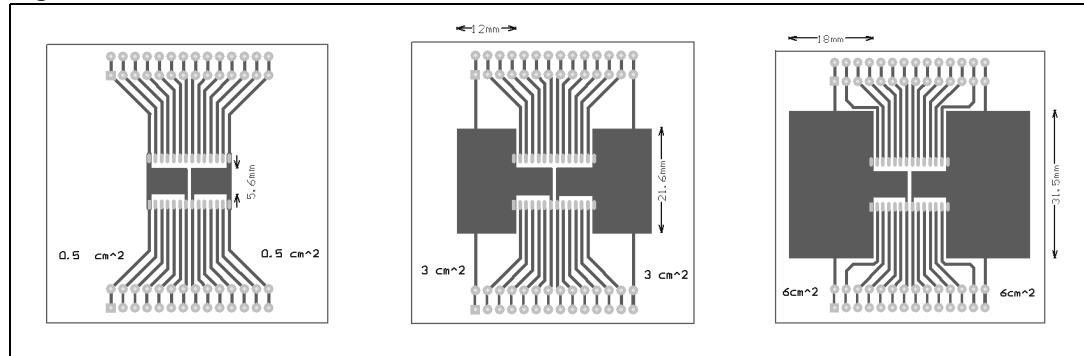

Note: Layout condition of  $R_{th}$  and  $Z_{th}$  measurements (PCB FR4 area=58 mm x 58 mm, PCB thickness=2 mm, Cu thickness=35  $\mu$ m, Copper areas: 0.5 cm<sup>2</sup>, 3 cm<sup>2</sup>, 6 cm<sup>2</sup>).

Table 15. Thermal calculation according to the PCB heatsink area

Chip 1	Chip 2	$T_{jchip1}$	$T_{jchip2}$	Note
On	Off	$R_{thA} \times P_{dchip1} + T_{amb}$	$R_{thC} \times P_{dchip1} + T_{amb}$	
Off	On	$R_{thC} \times P_{dchip2} + T_{amb}$	$R_{thA} \times P_{dchip2} + T_{amb}$	
On	On	$R_{thB} \times (P_{dchip1} + P_{dchip2}) + T_{amb}$	$R_{thB} \times (P_{dchip1} + P_{dchip2}) + T_{amb}$	$P_{dchip1} = P_{dchip2}$
On	On	$(R_{thA} \times P_{dchip1}) + R_{thC} \times P_{dchip2} + T_{amb}$	$(R_{thA} \times P_{dchip2}) + R_{thC} \times P_{dchip1} + T_{amb}$	$P_{dchip1} \neq P_{dchip2}$

$R_{thA}$  = Thermal resistance Junction to Ambient with one chip on

$R_{thB}$  = Thermal resistance Junction to Ambient with both chips on and  $P_{dchip1} = P_{dchip2}$

$R_{thC}$  = Mutual thermal resistance

Figure 23.  $R_{thj-amb}$  Vs PCB copper area in open box free air condition

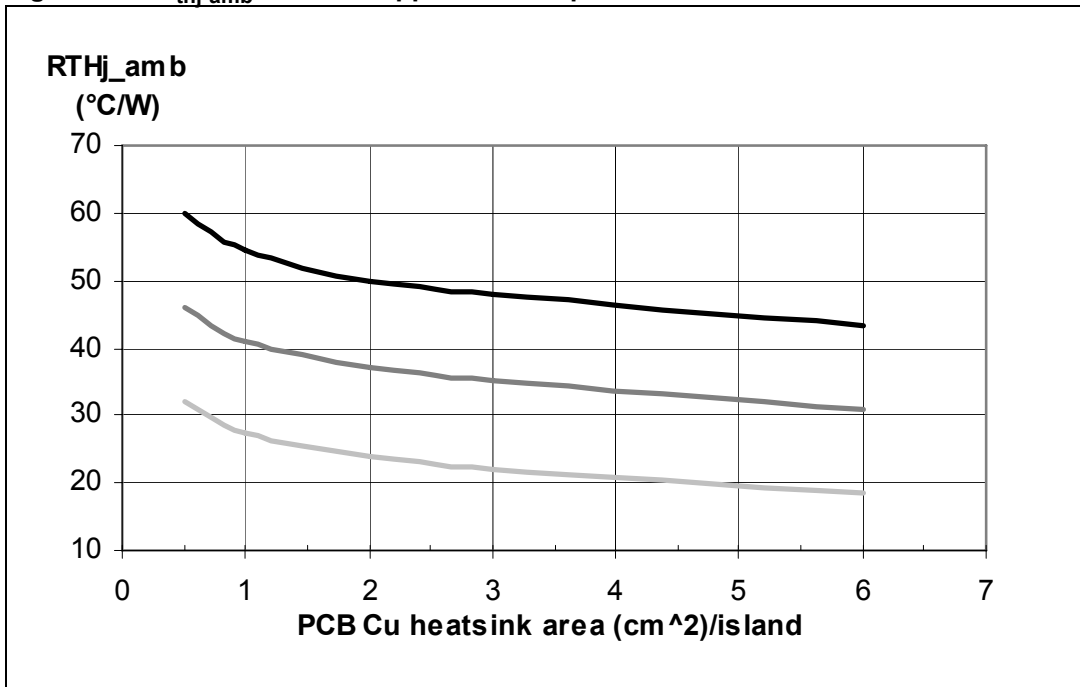
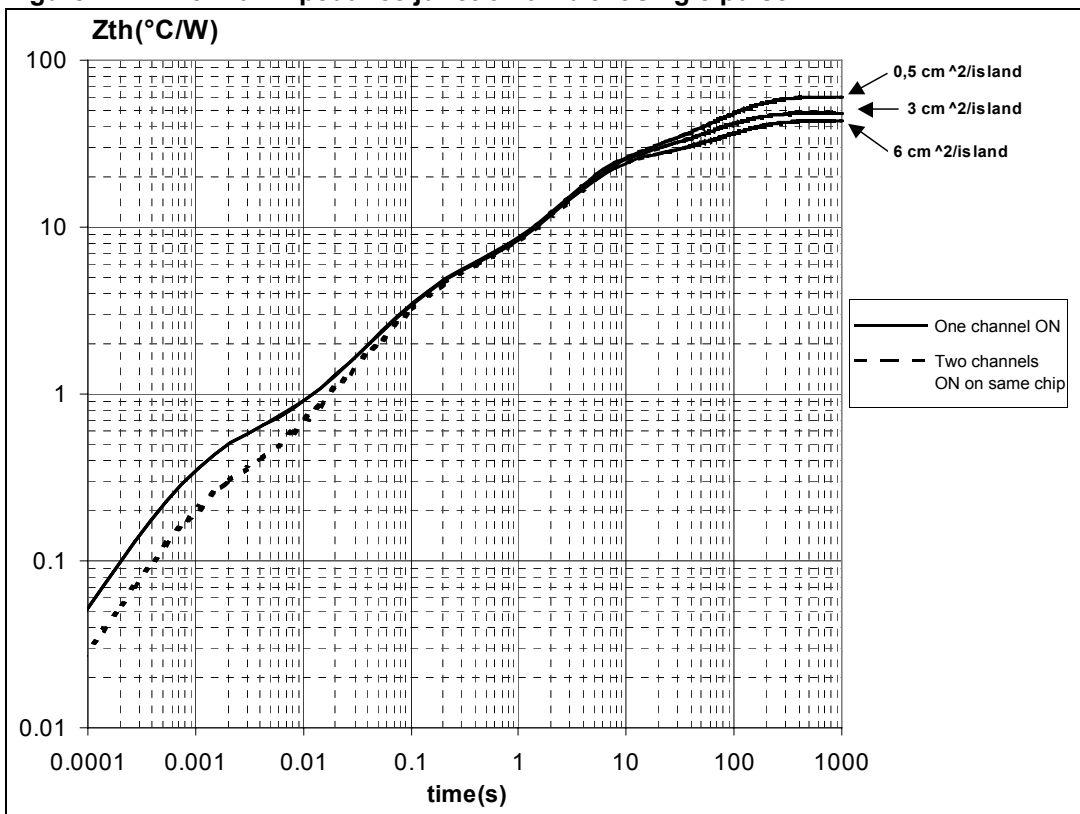

Figure 24. Thermal impedance junction ambient single pulse



**Equation 1: pulse calculation formula**

$$Z_{TH\delta} = R_{TH} \cdot \delta + Z_{THtp}(1 - \delta)$$

where  $\delta = t_p/T$

**Figure 25. Thermal fitting model of a quad channel HSD in SO-28**

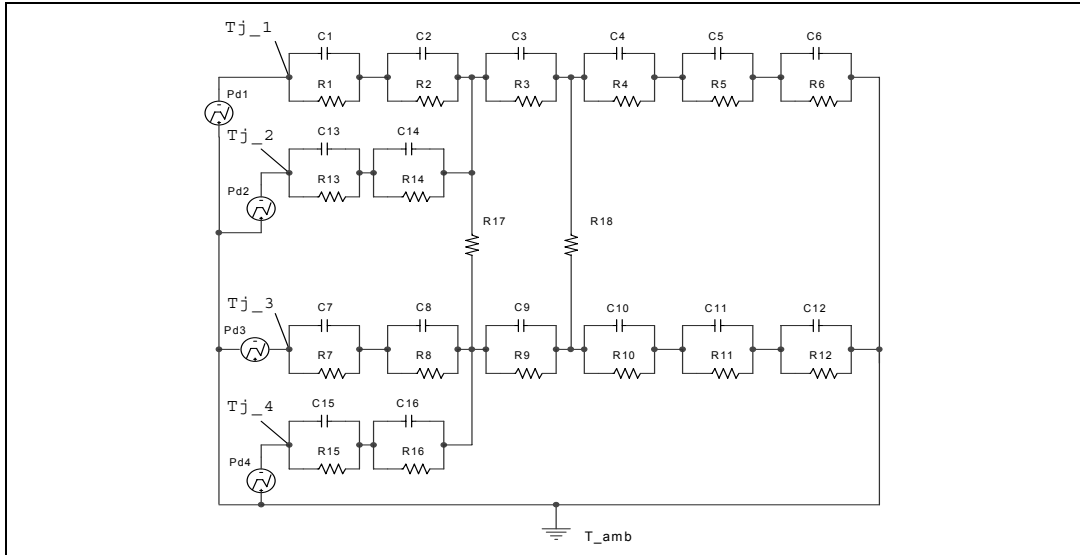

**Table 16. Thermal parameter**

Area/island (cm <sup>2</sup> )	0.5	6
R1=R7=R13=R15 (°C/W)	0.05	-
R2=R8=R14=R16 (°C/W)	0.3	-
R3=R9 (°C/W)	3.4	-
R4=R10 (°C/W)	11	-
R5=R11 (°C/W)	15	-
R6=R12 (°C/W)	30	13
C1=C7=C13=C15 (W.s/°C)	0.001	-
C2=C8=C14=C16 (W.s/°C)	5.00E-03	-
C3=C9 (W.s/°C)	1.00E-02	-
C4=C10 (W.s/°C)	0.2	-
C5=C11 (W.s/°C)	1.5	-
C6=C12 (W.s/°C)	5	8
R17=R18 (°C/W)	150	-

## 5 Package and packing information

### 5.1 ECOPACK® packages

In order to meet environmental requirements, ST offers these devices in different grades of ECOPACK® packages, depending on their level of environmental compliance. ECOPACK® specifications, grade definitions and product status are available at: [www.st.com](http://www.st.com).

ECOPACK® is an ST trademark.

Figure 26. SO-28 package dimensions

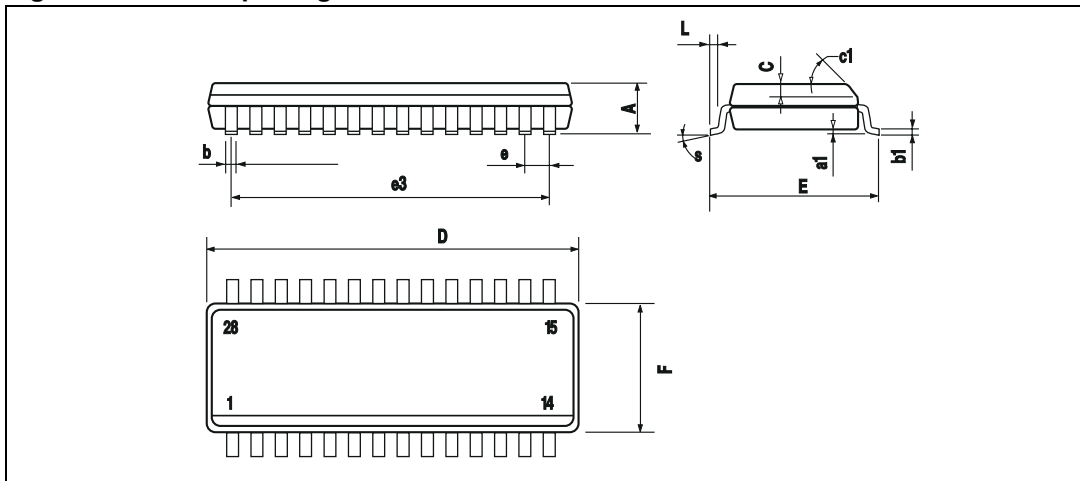

Table 17. SO-28 mechanical data

Dim.	mm.			inch		
	Min.	Typ	Max.	Min.	Typ.	Max.
A	-	-	2.65	-	-	0.104
a1	0.10	-	0.30	0.004	-	0.012
b	0.35	-	0.49	0.013	-	0.019
b1	0.23	-	0.32	0.009	-	0.012
C	-	0.50	-	-	0.020	-
c1	45 (typ.)			-		
D	17.7	-	18.1	0.697	-	0.713
E	10.00	-	10.65	0.393	-	0.419
e	-	1.27	-	-	0.050	-
e3	-	16.51	-	-	0.650	-
F	7.40	-	7.60	0.291	-	0.299
L	0.40	-	1.27	0.016	-	0.050
S	8 (max.)			-		

## 5.2 SO-28 packing information

Figure 27. SO-28 tube shipment (no suffix)

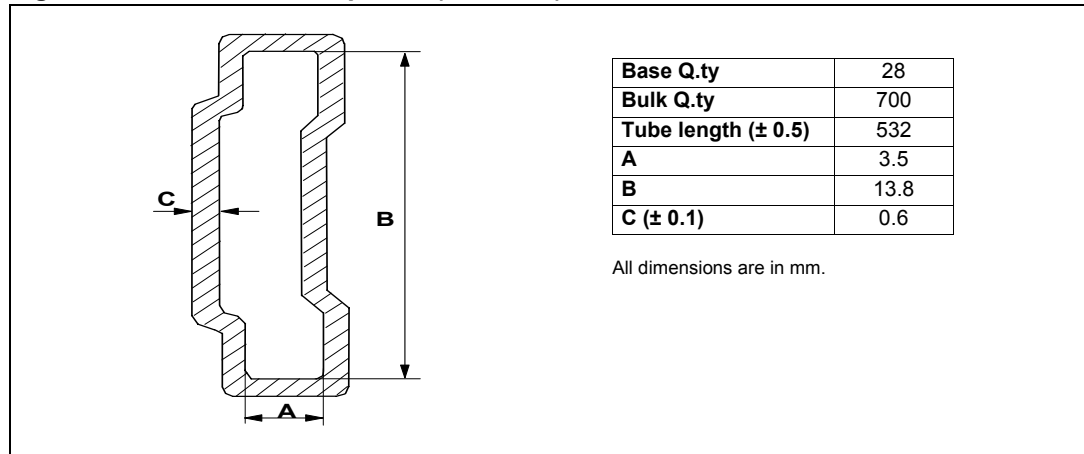
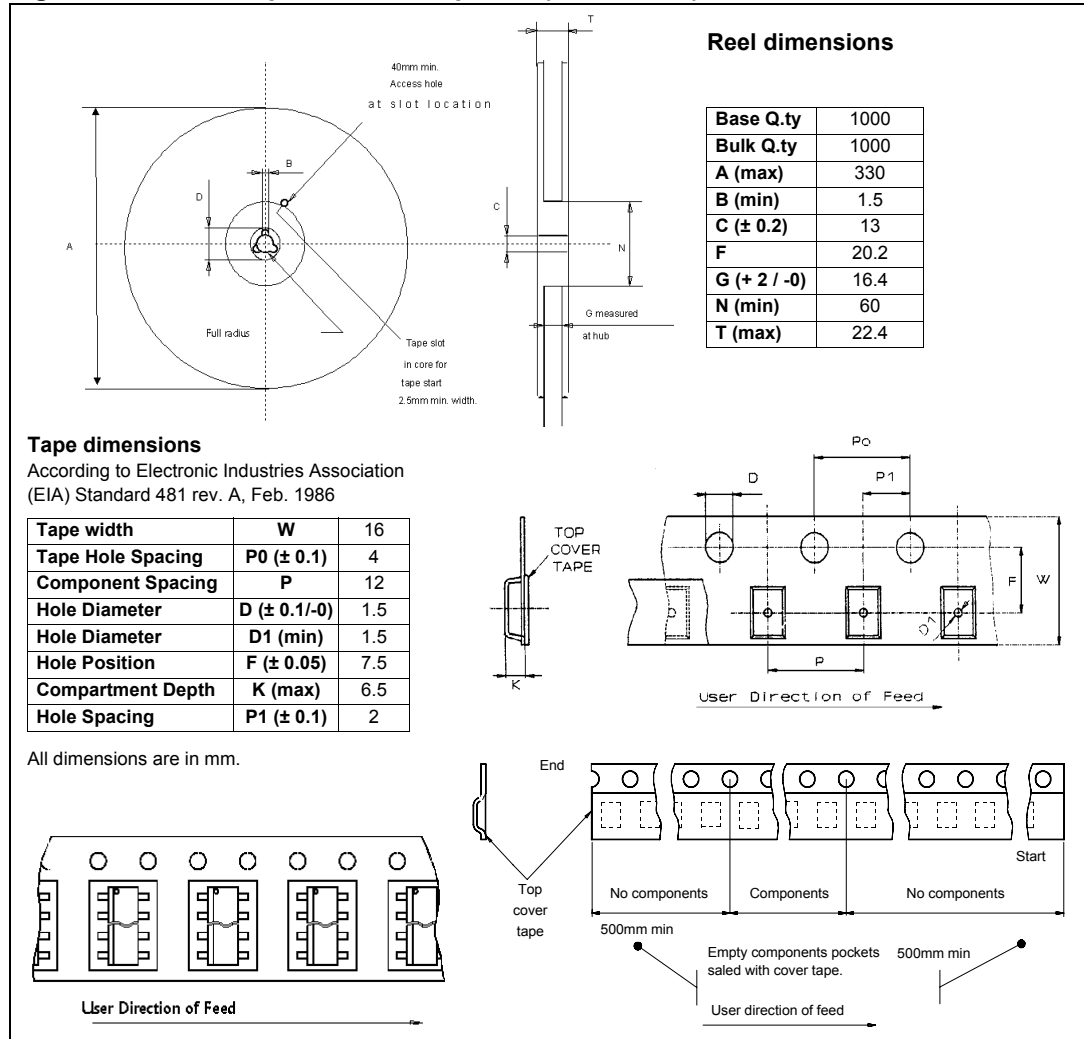

Figure 28. SO-28 tape and reel shipment (suffix "TR")





## 6 Revision history

Table 18. Document revision history

Date	Revision	Changes
01-Oct-2004	1	Initial release.
08-Jun-2009	2	Features: – Changed <i>I<sub>lim</sub></i> value from 22 A to 25 A – Changed DC short circuit current value from 22 A to 25 A <i>Table 9</i> : changed <i>I<sub>lim</sub></i> min value from 22 A to 25 A
15-Oct-2009	3	Updated <i>Figure 2: Configuration diagram (top view)</i> .

**Please Read Carefully:**

Information in this document is provided solely in connection with ST products. STMicroelectronics NV and its subsidiaries ("ST") reserve the right to make changes, corrections, modifications or improvements, to this document, and the products and services described herein at any time, without notice.

All ST products are sold pursuant to ST's terms and conditions of sale.

Purchasers are solely responsible for the choice, selection and use of the ST products and services described herein, and ST assumes no liability whatsoever relating to the choice, selection or use of the ST products and services described herein.

No license, express or implied, by estoppel or otherwise, to any intellectual property rights is granted under this document. If any part of this document refers to any third party products or services it shall not be deemed a license grant by ST for the use of such third party products or services, or any intellectual property contained therein or considered as a warranty covering the use in any manner whatsoever of such third party products or services or any intellectual property contained therein.

**UNLESS OTHERWISE SET FORTH IN ST'S TERMS AND CONDITIONS OF SALE ST DISCLAIMS ANY EXPRESS OR IMPLIED WARRANTY WITH RESPECT TO THE USE AND/OR SALE OF ST PRODUCTS INCLUDING WITHOUT LIMITATION IMPLIED WARRANTIES OF MERCHANTABILITY, FITNESS FOR A PARTICULAR PURPOSE (AND THEIR EQUIVALENTS UNDER THE LAWS OF ANY JURISDICTION), OR INFRINGEMENT OF ANY PATENT, COPYRIGHT OR OTHER INTELLECTUAL PROPERTY RIGHT.**

**UNLESS EXPRESSLY APPROVED IN WRITING BY AN AUTHORIZED ST REPRESENTATIVE, ST PRODUCTS ARE NOT RECOMMENDED, AUTHORIZED OR WARRANTED FOR USE IN MILITARY, AIR CRAFT, SPACE, LIFE SAVING, OR LIFE SUSTAINING APPLICATIONS, NOR IN PRODUCTS OR SYSTEMS WHERE FAILURE OR MALFUNCTION MAY RESULT IN PERSONAL INJURY, DEATH, OR SEVERE PROPERTY OR ENVIRONMENTAL DAMAGE. ST PRODUCTS WHICH ARE NOT SPECIFIED AS "AUTOMOTIVE GRADE" MAY ONLY BE USED IN AUTOMOTIVE APPLICATIONS AT USER'S OWN RISK.**

Resale of ST products with provisions different from the statements and/or technical features set forth in this document shall immediately void any warranty granted by ST for the ST product or service described herein and shall not create or extend in any manner whatsoever, any liability of ST.

ST and the ST logo are trademarks or registered trademarks of ST in various countries.

Information in this document supersedes and replaces all information previously supplied.

The ST logo is a registered trademark of STMicroelectronics. All other names are the property of their respective owners.

© 2009 STMicroelectronics - All rights reserved

STMicroelectronics group of companies

Australia - Belgium - Brazil - Canada - China - Czech Republic - Finland - France - Germany - Hong Kong - India - Israel - Italy - Japan - Malaysia - Malta - Morocco - Philippines - Singapore - Spain - Sweden - Switzerland - United Kingdom - United States of America

[www.st.com](http://www.st.com)