

RoHS compliant

FEATURES

1. N a P i O n pyroelectric sensor modules contain the necessary functions in a small package (TO-5). These miniature, high-performance infrared human detection sensors take the trouble out of circuit design and mounting.

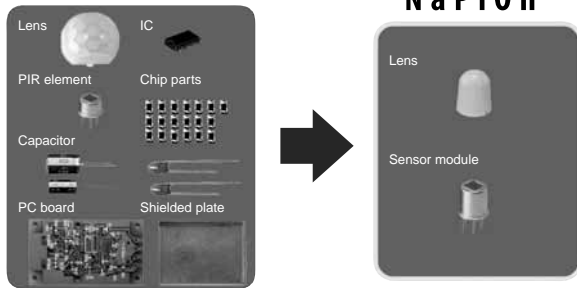

2. Ideal for small-movement detection thanks to quad-type pyroelectric element. The quad-type pyroelectric element contained in N a P i O n has four receptors. Since the detection zone within the detection range is so precise, even small movements can be detected.

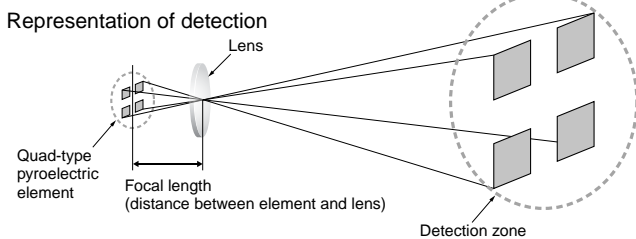

3. Lenses can be miniaturized because the pyroelectric element is small. A short focal length is all that's required even when detecting at the same distance, because the size of the N a P i O n pyroelectric element is so small. This means that high precision is maintained even though the lens is small and the sensor itself has been miniaturized.

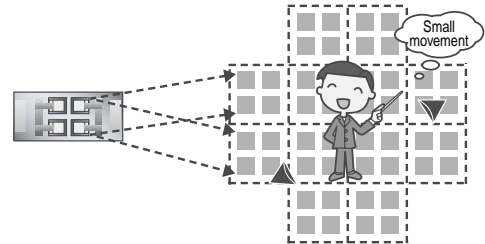

4. Small temperature differences also detected. N a P i O n detects the temperature difference between the detection target and its surroundings, and the lowest required temperature difference to the background is 4°C 7.2°F.

This means that temperature differences can be accurately detected not only in winter, when the temperature differences are large, but also in summer, when temperature differences are slight.

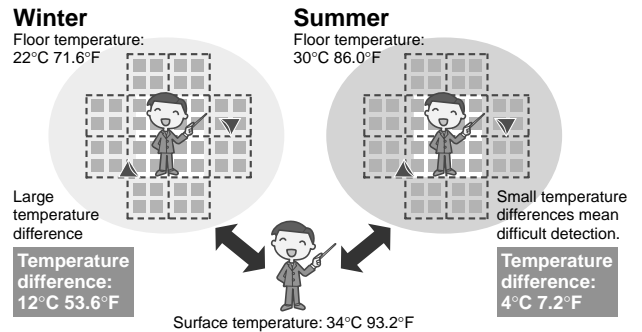

5. Excellent noise resistance (radiation noise, power supply noise) The entire N a P i O n circuitry is enclosed in a metal package, which means it has extremely high electromagnetic shielding capabilities. With proven resistance against power supply noise, it is also resistant against power supply superimposed noise.

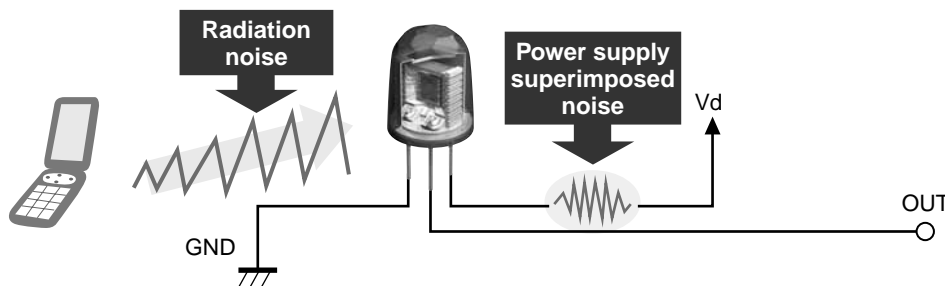

MP Motion Sensor (AMN2, 3, 4)

TYPICAL APPLICATIONS

1. Home appliance market: Air conditioner, air purifier and fan heater
2. Construction equipment: lighting, automatic switches
3. Commercial equipment: vending machines, facilities for designated smoking areas

4. Anti-crime device market: crime prevention sensor, simple anti-crime devices, surveillance cameras

ORDERING INFORMATION

Output type	AMN			1		
2: Analog output						
3: Digital output						
Detection performance						
1: Standard detection type						
2: Slight motion detection type						
3: Spot detection type						
4: 10m detection type						
Feature						
1: PC board mounting type						
Operating voltage						
1: 5V DC						
2: 3V DC						
Lens color						
1: Black						
2: White						

PRODUCT TYPES

Detection performance	Output type		Digital output	Low current consumption type Digital output	Analog output
	Lens color				
Standard detection type	Black		AMN31111	AMN41121	AMN21111
	White		AMN31112	AMN41122	AMN21112
Slight motion detection type	Black		AMN32111	AMN42121	AMN22111
	White		AMN32112	AMN42122	AMN22112
Spot detection type	Black		AMN33111	AMN43121	AMN23111
	White		AMN33112	AMN43122	AMN23112
10m detection type	Black		AMN34111	AMN44121	AMN24111
	White		AMN34112	AMN44122	AMN24112

Standard packing: Carton: 50 pcs.; Case: 1,000 pcs.

RATING

1. Detection performance

Items	Standard detection type	Slight motion detection type	Spot detection type	10m detection type	Conditions of objects to be detected
Rated detection distance Note 1)	Max. 5m 16.404ft	Max. 2m 6.562ft	Max. 5m 16.404ft	Max. 10m 32.808ft	1. Detectable difference in temperature between the target and background is more than 4°C 7.2°F. 2. Movement speed 1) Digital output type • Standard detection type/Spot detection type/ 10m detection type: 0.8 to 1.2 m/s • Slight motion detection type: 0.5 m/s 2) Analog output and low current consumption types • Standard detection type/Spot detection type/ 10m detection type: 0.5 to 1.5 m/s • Slight motion detection type: 0.3 to 1.0 m/s 3. Detection object = human body (size is 700mm × 250mm 27.559inch × 9.843inch, but for the slight motion detection type the size is 200mm × 200mm 7.874inch × 7.874inch)
Detection range	Horizontal Note 2)	91°	38°	110°	
	Vertical Note 2)	91°	22°	93°	
	Detection zone Note 3)	64 zones	104 zones	24 zones	80 zones

Notes: 1. Depending on the difference in temperature between the background and detection target and the speed at which the target moves, these sensors may be capable of detection beyond the detection distances stated above. Nevertheless, they should be used within the prescribed detection distances. For further details, refer to the detection range diagram on page 24.

2.

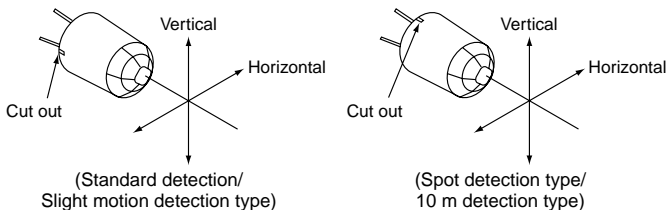

This angle represents the center point of the detection zone created by the outermost lens.

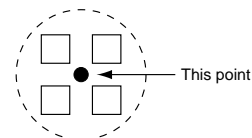

3. Regarding of detection zone, please refer to "DETECTION PERFORMANCE" on page 24.

MP Motion Sensor (AMN2, 3, 4)

2. Absolute maximum ratings (Measuring condition: ambient temperature = 25°C 77°F) (Common to All types)

Items	Absolute maximum ratings
Power supply voltage	-0.3 to 7 V DC
Usable ambient temperature	-20 to 60°C -4 to +140°F (No freezing and condensing at low temperature.)
Storage temperature	-20 to 70°C -4 to +158°F

3. Electrical characteristics (Common to All types)

1) Digital output

Items	Symbol	Electrical characteristics *() is low current consumption type	Measured conditions *() is low current consumption type
Rated operating voltage	Minimum	3.0 V DC (2.2 V DC)	
	Maximum	6.0 V DC (3.0 V DC)	
Rated consumption current (Standby) Note)	Typical	170 μA (46 μA)	Ambient temperature = 25°C 77°F Operating voltage = 5V (3V) Iout = 0
	Maximum	300 μA (60 μA)	
Output current (when detecting)	Maximum	Iout	Ambient temperature = 25°C 77°F Operating voltage = 5V (3V) Vout ≥ Vdd-0.5
Output voltage (when detecting)	Minimum	Vout	Ambient temperature = 25°C 77°F Operating voltage = 5V (3V) Open when not detecting
Circuit stability time	Typical	Twu	Ambient temperature = 25°C 77°F Operating voltage = 5V (3V)
	Maximum		

Note: The current which is consumed during detection consists of the standby consumed current plus the output current.

2) Analog output

Items	Symbol	Specified value	Measured conditions
Operating voltage	Minimum	4.5 V DC	
	Maximum	5.5 V DC	
Consumption current	Typical	170 μA	Ambient temperature = 25°C 77°F Operating voltage = 5V (3V) Iout = 0
	Maximum	300 μA	
Output current	Maximum	Iout	Ambient temperature = 25°C 77°F Operating voltage = 5V (3V)
Output voltage range	Minimum	Vout	Ambient temperature = 25°C 77°F Operating voltage = 5V (3V)
	Maximum		
Output offset average voltage	Minimum	Voff	Ambient temperature = 25°C 77°F Operating voltage = 5V (3V) Steady-state output voltage when not detecting
	Typical		
	Maximum		
Steady-state noise	Typical	Vn	Ambient temperature = 25°C 77°F Operating voltage = 5V (3V)
	Maximum		
Detection sensitivity	Minimum	Vh or Vl	Ambient temperature = 25°C 77°F Operating voltage = 5V (3V) Temperature difference with background: 4°C 39.2°F Please refer to conditions of other detection objects.
Circuit stability time	Maximum	Twu	Ambient temperature = 25°C 77°F Operating voltage = 5V (3V)

Note: To set to the same detection performance as the digital output type, set the output voltage to the offset voltage (2.5V) ±0.45V (i.e. 2.95V or more and 2.05V or less).

TIMING CHART

1. Digital output

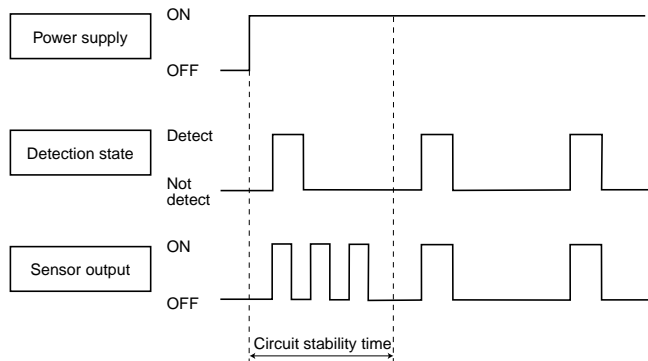

Note: Circuit stability time: 30s max.

While the circuitry is stabilizing after the power is turned on, the sensor output is not fixed in the "on" state or "off" state. This is true regardless of whether or not the sensor has detected anything.

2. Analog output

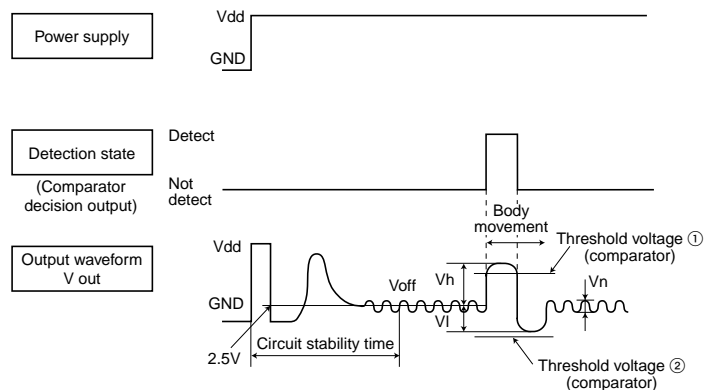

Note: Circuit stability time: 45s max.

While the circuitry is stabilizing after the power is turned on, the sensor output is not fixed in the "on" state or "off" state. This is true regardless of whether or not the sensor has detected anything.

MP Motion Sensor (AMN2, 3, 4)

DETECTION PERFORMANCE

1. Standard detection type

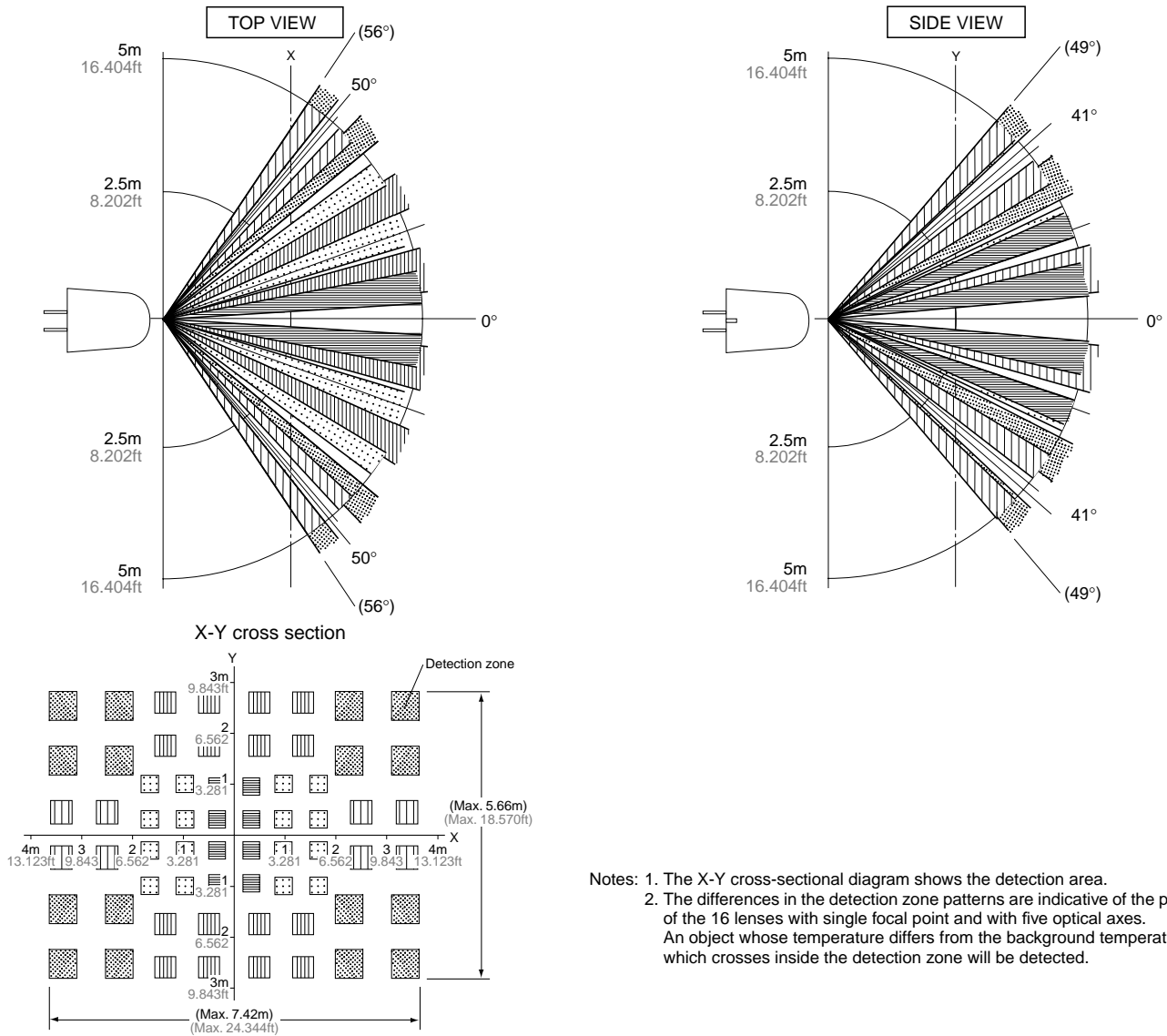

- Notes: 1. The X-Y cross-sectional diagram shows the detection area.
2. The differences in the detection zone patterns are indicative of the projections of the 16 lenses with single focal point and with five optical axes. An object whose temperature differs from the background temperature and which crosses inside the detection zone will be detected.

2. Slight motion detection type

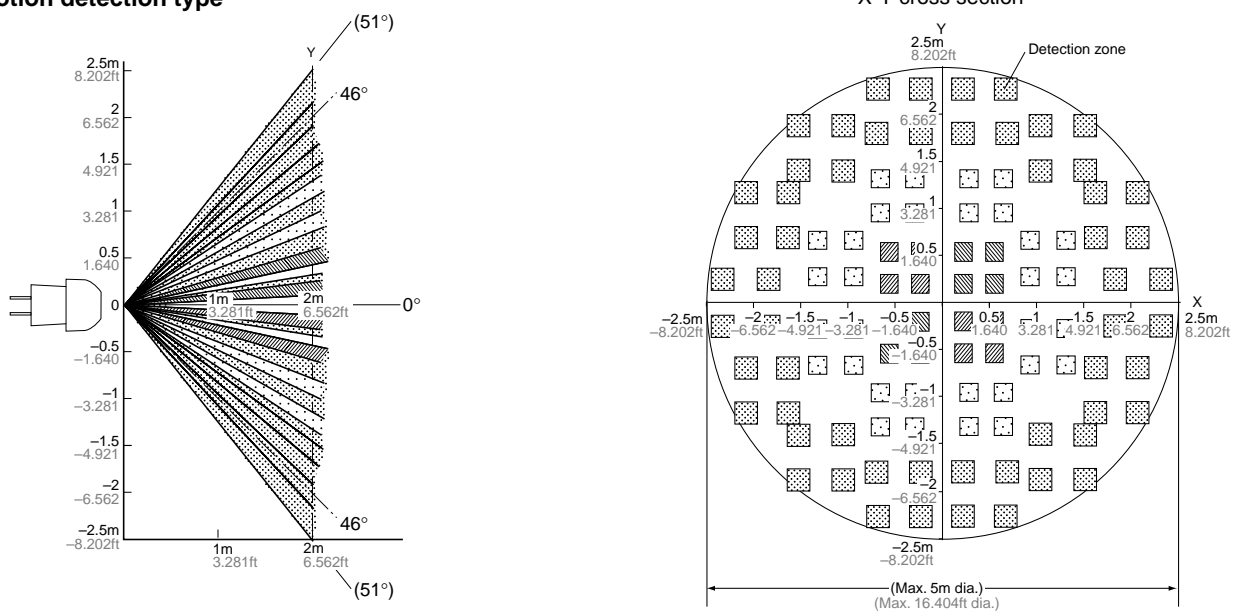

- Notes: 1. The X-Y cross-sectional diagram shows the detection area.
2. The differences in the detection zone patterns are indicative of the projections of the 26 lenses with single focal point and with three optical axes. An object whose temperature differs from the background temperature and which crosses inside the detection zone will be detected.

3. Spot detection type

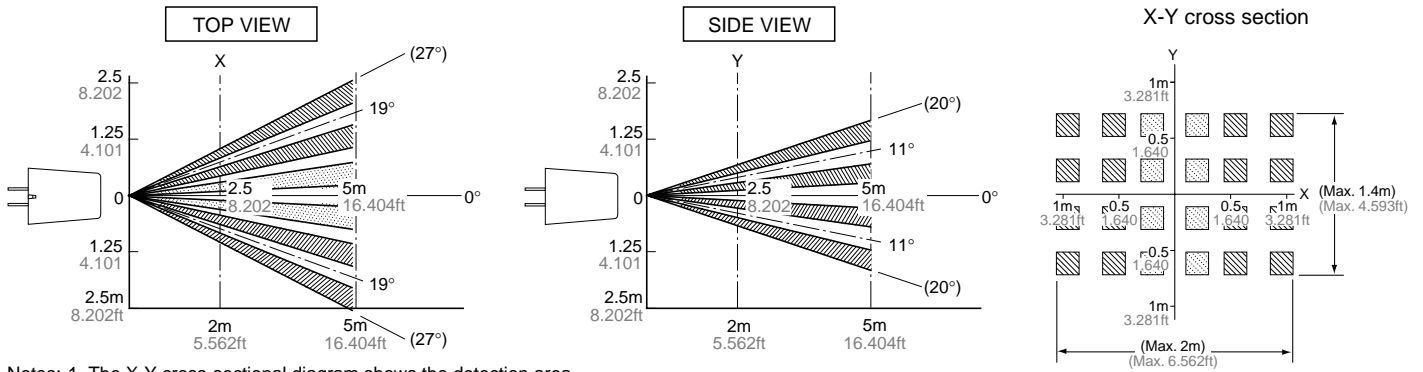

Notes: 1. The X-Y cross-sectional diagram shows the detection area.
 2. The differences in the detection zone patterns are indicative of the projections of the 6 lenses with single focal point and with two optical axes.
 An object whose temperature differs from the background temperature and which crosses inside the detection zone will be detected.

4. 10m detection type

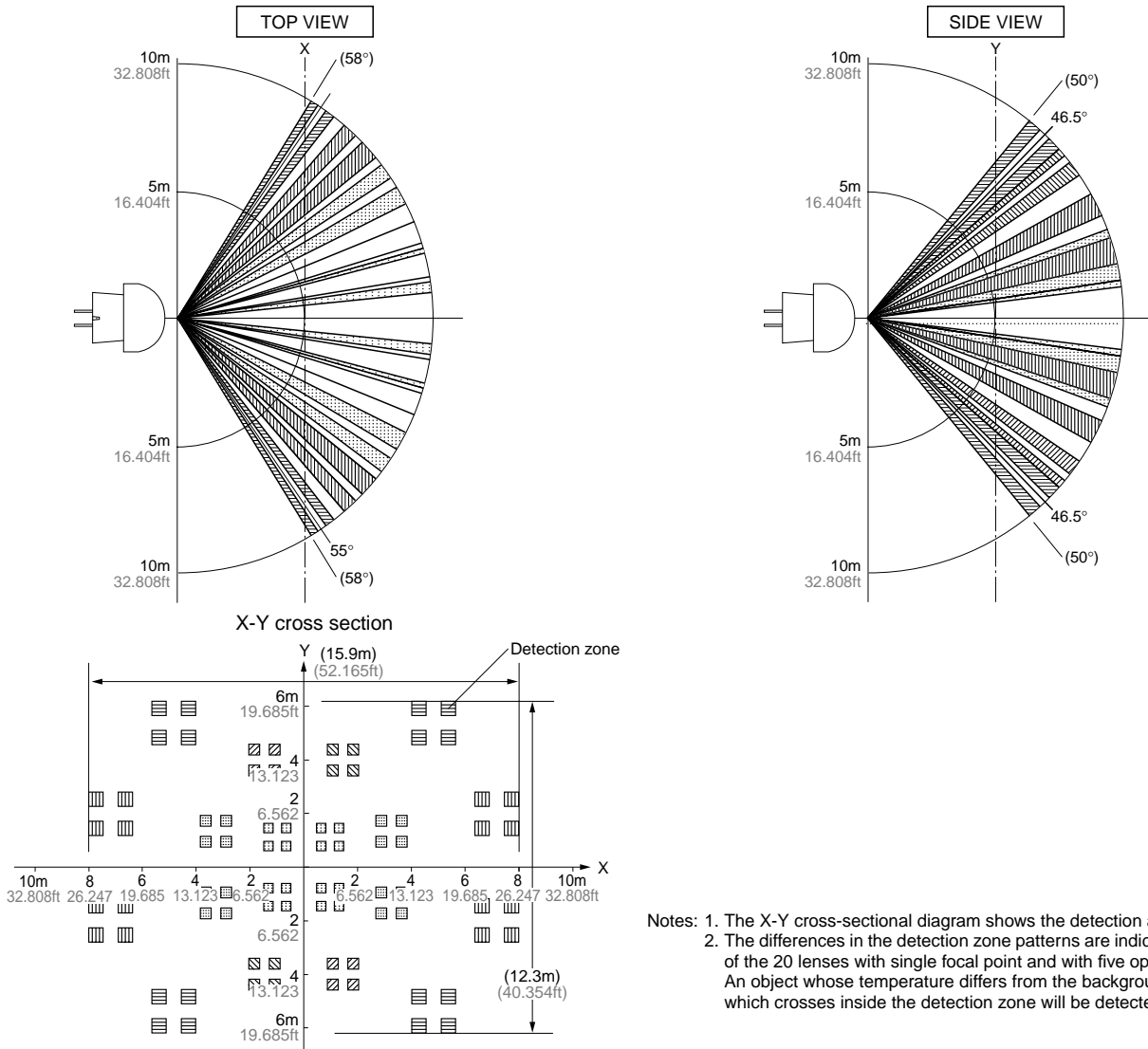

Notes: 1. The X-Y cross-sectional diagram shows the detection area.
 2. The differences in the detection zone patterns are indicative of the projections of the 20 lenses with single focal point and with five optical axes.
 An object whose temperature differs from the background temperature and which crosses inside the detection zone will be detected.

5. Notes regarding the detection zone

The detection zone has the polarity shown in the diagram on the right.
 When targets enter both the + and - zones with the same timing, the signals are cancelled each other, thus in this case there is a possibility that the object cannot be detected at the maximum specified detection distance.

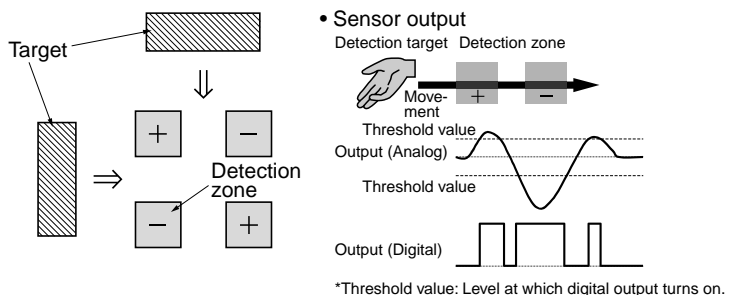

MP Motion Sensor (AMN2, 3, 4)

HOW TO USE

1. Block diagram output circuit

1) Block diagram of the digital output circuit

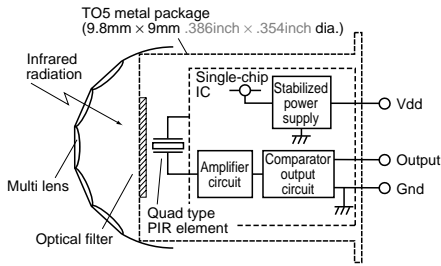

2) Block diagram of the analog output circuit

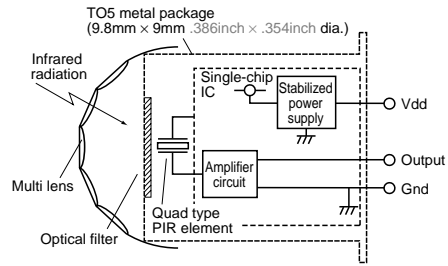

2. Wiring diagram

1) Digital output

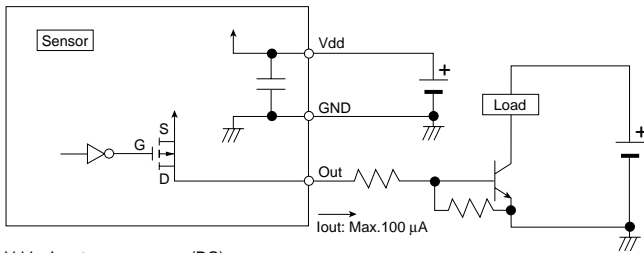

Vdd: Input power source (DC)
GND: GND
Out: Output (Comparator)

2) Analog output

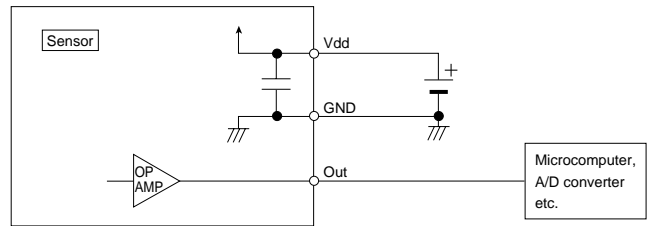

3. Timer circuit example

1) Digital output

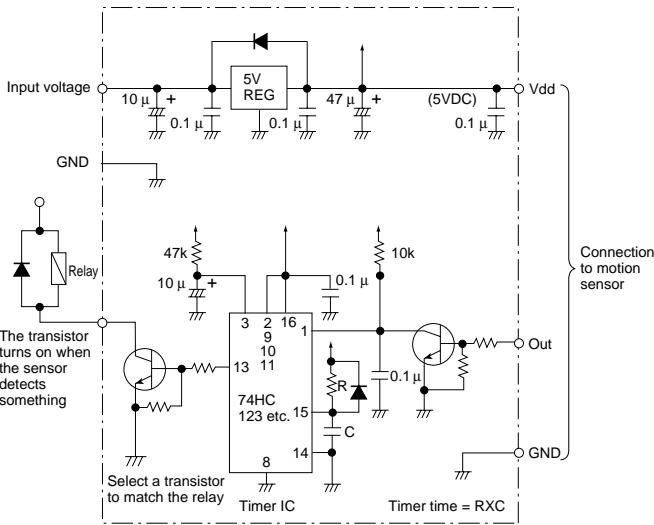

2) Analog output

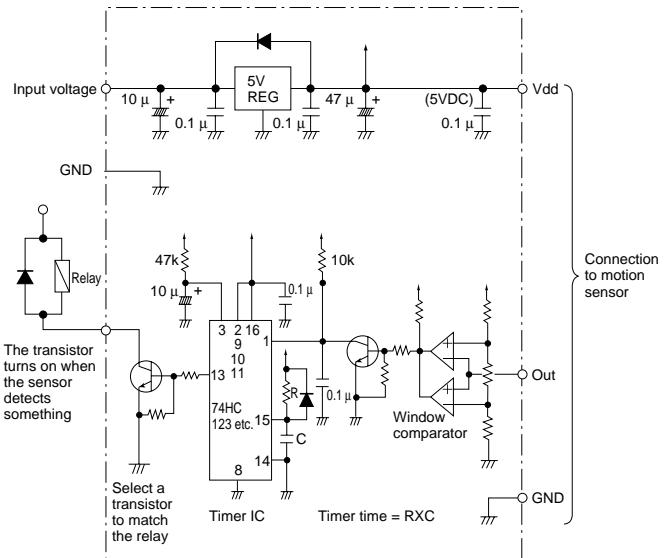

Note: This is the reference circuit which drives the MP motion sensor. Install a noise filter for applications requiring enhanced detection reliability and noise withstanding capability.

Differences in the specifications of electronic components to which the units are connected sometimes affect their correct operation; please check the units' performance and reliability for each application.

Panasonic Corporation accepts no responsibility for damages resulting from the use of this circuit.

4. Installation

Install the sensor so that people will be entering from the X direction shown below.

(If persons approach the sensor from the Z direction, detection distance will be shortened.)

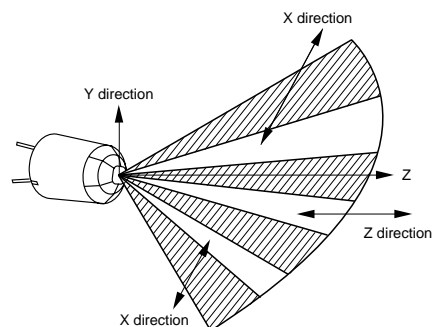

MP Motion Sensor (AMN2, 3, 4)

DIMENSIONS (mm inch)

The CAD data of the products with a **CAD Data** mark can be downloaded from: <http://industrial.panasonic.com/ac/e>

1. Standard detection type

CAD Data



General tolerance $\pm 0.5 \pm .020$

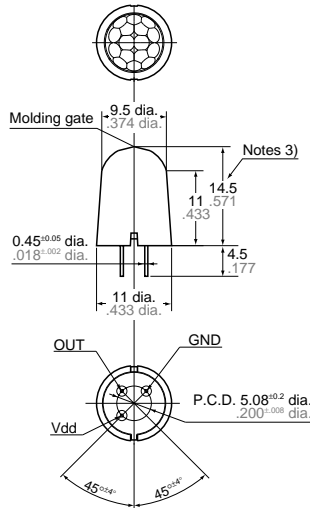

Recommended panel mounting hole

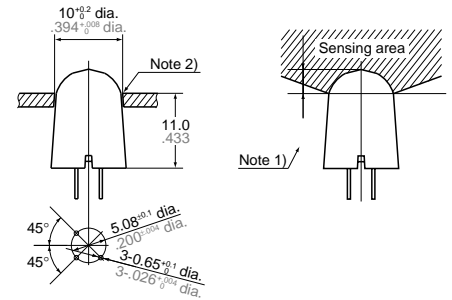

- Notes: 1. In order to ensure proper detection, install it with the lens exposed at least 3.5mm .138inch.
2. As for panel mounting hole, tapering or making a large size hole should be done.
3. The height dimension does not include the remaining molding gate.

2. Slight motion detection type

CAD Data

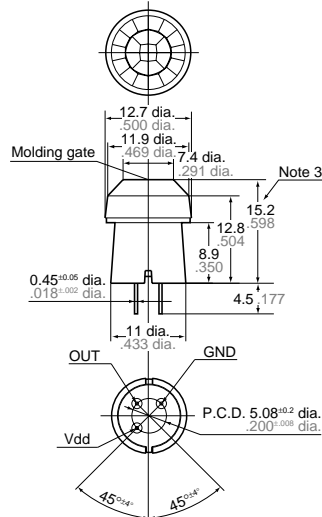

Recommended panel mounting hole

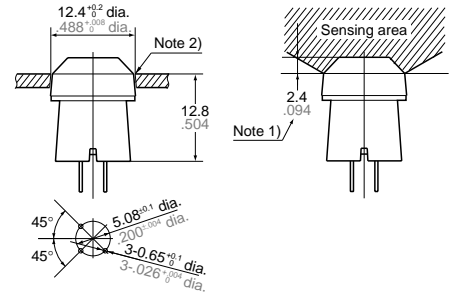

- Notes: 1. In order to ensure proper detection, install it with the lens exposed at least 2.4mm .094inch.
2. As for panel mounting hole, tapering or making a large size hole should be done.
3. The height dimension does not include the remaining molding gate.

3. Spot detection type

CAD Data

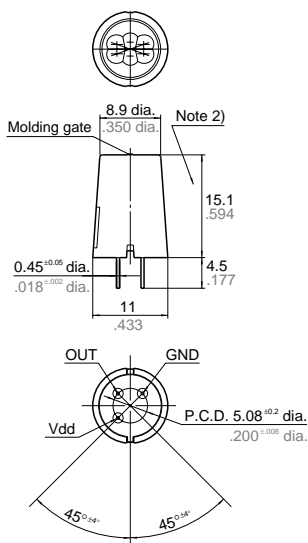

Recommended panel mounting hole

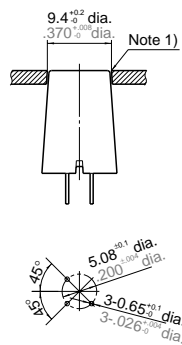

- Notes: 1. As for panel mounting hole, tapering or making a large size hole should be done.
2. The height dimension does not include the remaining molding gate.

4. 10m detection type

CAD Data

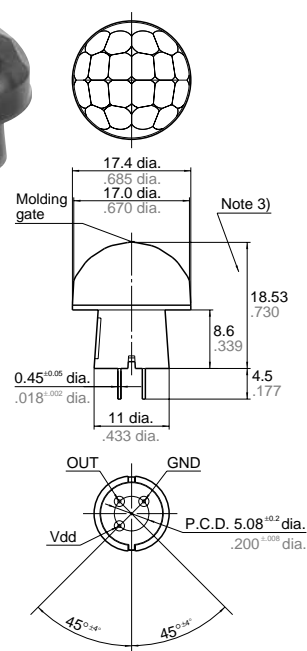

Recommended panel mounting hole

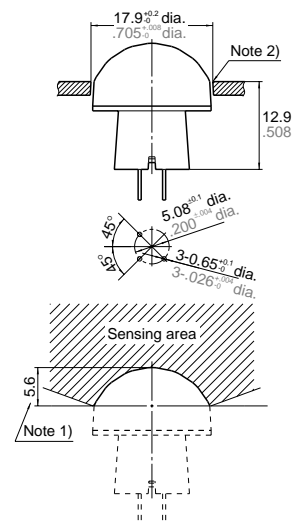

- Notes: 1. In order to ensure proper detection, install it with the lens exposed at least 5.6mm .220inch.
2. As for panel mounting hole, tapering or making a large size hole should be done.
3. The height dimension does not include the remaining molding gate.

MP Motion Sensor (AMN2, 3, 4)

NOTES

1. Checkpoints relating to principle of operation

MP motion sensors are passive infrared sensors which detect changes in the infrared rays. They may fail to detect successfully if a heat source other than a human being is detected or if there are no temperature changes in or movement of a heat source. Care must generally be taken in the following cases. The performance and reliability of the sensors must be checked out under conditions of actual use.

1) Cases where a heat source other than a human being is detected.

(1) When a small animal enters the detection range.

(2) When the sensor is directly exposed to sunlight, a vehicle's headlights, an incandescent light or some other source of far infrared rays.

(3) When the temperature inside the detection range has changed suddenly due to the entry of cold or warm air from an air-conditioning or heating unit, water vapor from a humidifier, etc.

2) Cases where it is difficult to detect the heat source

(1) When an object made of glass, acrylic or other subject which far infrared rays have difficulty passing through is located between the sensor and what is to be detected.

(2) When the heat source inside the detection range hardly moves or when it moves at high speed; for details on the movement speed, refer to the section on the performance ratings.

2. When the detection area becomes larger

When the difference between the ambient temperature and body temperature is large (more than 20°C 68°F), detection may occur in isolated areas outside the specified detection range.

3. Other handling cautions

1) Be careful not to allow dust or dirt to accumulate on the lens as this will adversely affect the detection sensitivity.

2) The lens is made of a soft material (polyethylene).

Avoid applying a load or impact since this will deform or scratch the lens, making proper operation impossible and causing a deterioration in its performance.

3) The sensor may be damaged if it is exposed to static with a voltage exceeding $\pm 200\text{V}$. Therefore, do not touch its terminals directly, and exercise adequate care in the handling of the sensor.

4) When the leads are to be soldered, solder them by hand for less than 3 seconds at a temperature of less than 350°C 662°F at the tip of the soldering iron. Avoid using a solder bath since this will cause a deterioration in the sensor's performance.

5) Do not attempt to clean the sensor. Cleaning fluid may enter inside the lens area causing a deterioration in performance.

6) When using the sensors with cables, it is recommended that cables which are shielded and as short as possible be used in order to safeguard against the effects of noise.

For Cautions for Use.