



Document Title	HSD100IXN1 Formal Standard Specification	Page No.	1/31
Document No.		Revision	1.0

TO :

Date : May, 27, 2010

# Customer Acceptance Specification

## 10" Color TFT-LCD Module

Model: HSD100IXN1

**-A\*\***

相關文件：

Accepted by:	
Signature	Date
Proposed by: Technical Service Division	
Signature	Date

Note:

1. Please contact HannStar Display Corp. before designing your product based on this module specification.
2. The information contained herein is presented merely to indicate the characteristics and performance of our products. No responsibility is assumed by HannStar for any intellectual property claims or other problems that may result from application based on the module described herein.



Document Title	HSD100IXN1 Formal Standard Specification	Page No.	2/31
Document No.		Revision	1.0

### Record of Revisions

Rev.	Date	Sub-Model	Description of change
1.0	May, 27, 2010	A**	Formal Product Specification was first released



Document Title	HSD100IXN1 Formal Standard Specification	Page No.	3/31
Document No.		Revision	1.0

## Contents

1.0	General description .....	p.4
2.0	Absolute maximum ratings.....	p.5
3.0	Optical characteristics.....	p.6
4.0	Block diagram .....	p.10
5.0	Interface pin connection .....	p.11
6.0	Electrical characteristics .....	p.13
7.0	Reliability test items .....	p.21
8.0	Outline dimension .....	p.22
9.0	Lot mark .....	p.23
10.0	Package specification .....	p.24
11.0	General precaution .....	p.25

Document Title	HSD100IXN1 Formal Standard Specification	Page No.	4/31
Document No.		Revision	1.0

## 1.0 GENERAL DESCRIPTION

### 1.1 Introduction

HannStar Display model HSD100IXN1-A\*\* is a color active matrix thin film transistor (TFT) liquid crystal display (LCD) that uses amorphous silicon TFT as a switching device. This model is composed of a TFT LCD panel, a driving circuit and a back light system. This TFT LCD has a 10 (4:3) inch diagonally measured active display area with XGA (1024 horizontal by 768 vertical pixel) resolution.

### 1.2 Features

- 10 (4:3 diagonal) inch configuration
- 6 bits driver with 1channel TTL interface
- RoHS and Halogen-Free Compliance

### 1.3 Applications

- Digital Photo frame
- Multimedia applications and Others AV system

### 1.4 General information

Item	Specification	Unit	
Outline Dimension	215.5 x 166.5 x 5.0 (Typ.)	mm	
Display area	202.752 (H) x 152.064 (V)	mm	
Number of Pixel	1024 RGB (H) x 768(V)	pixels	
Pixel pitch	0.198(H) x 0.198(V)	mm	
Pixel arrangement	RGB Vertical stripe		
Display mode	Normally white		
Surface treatment	Antiglare, Hard-Coating (3H)		
Weight	330 (Typ.)	g	
Back-light	Single LED (Side-Light type)		
Power Consumption	Logic System	0.75 (Max.)	W
	B/L System	2.64 (Max.)	W

### 1.5 Mechanical Information

Item	Min.	Typ.	Max.	Unit	
Module Size	Horizontal (H)	215.2	215.5	215.8	mm
	Vertical (V)	166.2	166.5	166.8	mm
	Depth (D)	—	5.0	5.3	mm
Weight	—	330	—	g	

Document Title	HSD100IXN1 Formal Standard Specification	Page No.	5/31
Document No.		Revision	1.0

## 2.0 ABSOLUTE MAXIMUM RATINGS

### 2.1 Electrical Absolute Rating

#### 2.1.1 TFT LCD Module

Item	Symbol	Min.	Max.	Unit	Note
Digital Supply voltage	VCC	-0.5	5	V	
Analog Supply voltage	AVDD	-0.5	13.5	V	
Supply voltage	V1~V7	0.4AVDD	AVDD+0.3	V	
	V8~V14	-0.3	0.6AVDD	V	
Digital input voltage	-	-0.5	VCC+0.5	V	

#### 2.1.2 Back-Light Unit

Item	Symbol	Typ.	Max.	Unit	Note
LED current	$I_L$	220	—	mA	(1) (2)(3)
LED voltage	$V_L$	10.5	—	V	(1) (2)(3)

- Note (1) Permanent damage may occur to the LCD module if beyond this specification. Functional operation should be restricted to the conditions described under normal operating conditions.
- (2)  $T_a = 25 \pm 2^\circ\text{C}$
- (3) Test Condition: LED current 220 mA. The LED lifetime could be decreased if operating  $I_L$  is larger than 220mA.

### 2.2 Environment Absolute Rating

Item	Symbol	Min.	Max.	Unit	Note
Operating Temperature	$T_{opa}$	-20	70	$^\circ\text{C}$	
Storage Temperature	$T_{stg}$	-30	80	$^\circ\text{C}$	

Document Title	HSD100IXN1 Formal Standard Specification	Page No.	6/31
Document No.		Revision	1.0

### 3.0 OPTICAL CHARACTERISTICS

#### 3.1 Optical specification

Item	Symbol	Condition	Min.	Typ.	Max.	Unit	Note	
Contrast	CR	Normal viewing angle	480	600	—		(1)(2)	
Response time	Rising		$T_R$	—	2.4	4.8	msec	(1)(3)
	Falling		$T_F$	—	5.6	11.2		
White luminance (Center)	$Y_L$			200	250	—	cd/m <sup>2</sup>	(1)(4) ( $I_L=220mA$ )
Color chromaticity (CIE1931)	White		$W_x$	0.260	0.310	0.360		(1)(4)
		$W_y$	0.280	0.330	0.380			
Viewing angle	Hor.	$\theta_L$	65	75	—		(1)(4)	
		$\theta_R$	65	75	—			
	Ver.	$\theta_U$	50	60	—			
		$\theta_D$	60	70	—			
Brightness uniformity	$B_{UNI}$	$\theta=0$	70	-	—	%	(5)	
Optima View Direction	6 O' clock						(6)	

#### 3.2 Measuring Condition

- Measuring surrounding : dark room
- LED current  $I_L$  : 220mA
- Ambient temperature : 25±2°C
- 15min. warm-up time.

Document Title	HSD100IXN1 Formal Standard Specification	Page No.	7/31
Document No.		Revision	1.0

### 3.3 Measuring Equipment

- FPM520 of Westar Display technologies, INC., which utilized SR-3 for Chromaticity and BM-5A for other optical characteristics.

- Measuring spot size : 20 ~ 21 mm

**Note (1)** Definition of Viewing Angle:

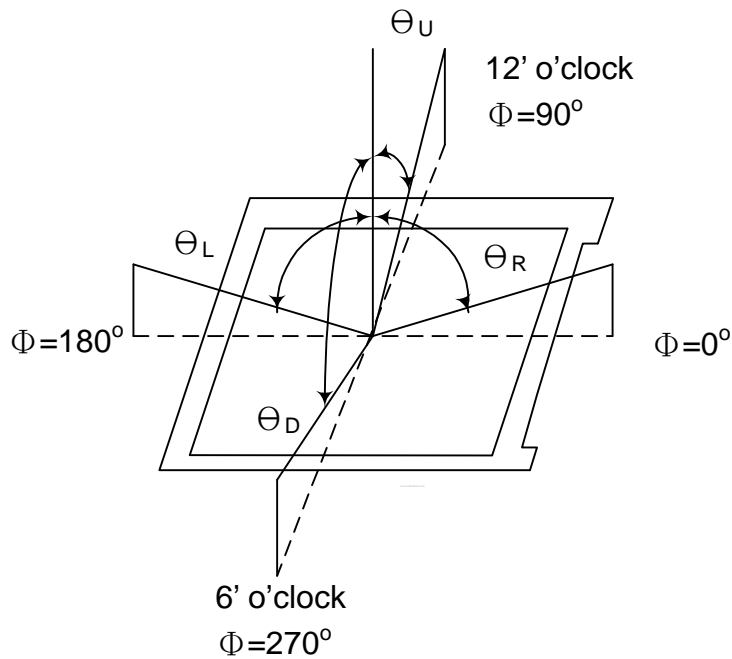

**Note (2)** Definition of Contrast Ratio (CR) :  
measured at the center point of panel

$$CR = \frac{\text{Luminance with all pixels white}}{\text{Luminance with all pixels black}}$$

Document Title	HSD100IXN1 Formal Standard Specification	Page No.	8/31
Document No.		Revision	1.0

**Note (3)** Definition of Response Time : Sum of  $T_R$  and  $T_F$

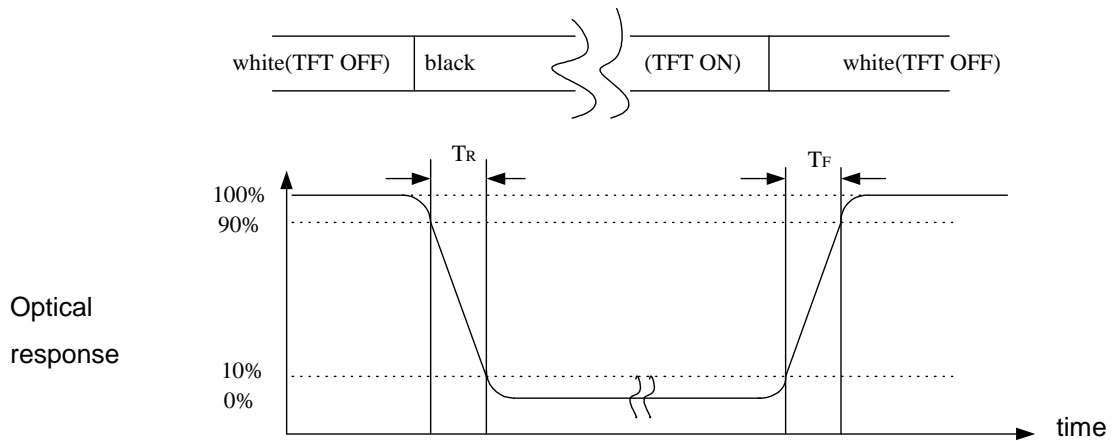

**Note (4)** Definition of optical measurement setup

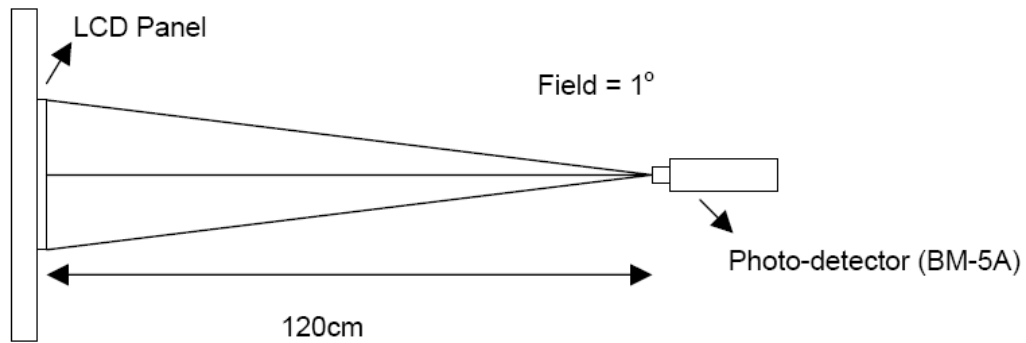



Document Title	HSD100IXN1 Formal Standard Specification	Page No.	9/31
Document No.		Revision	1.0

**Note (5)** Definition of brightness uniformity

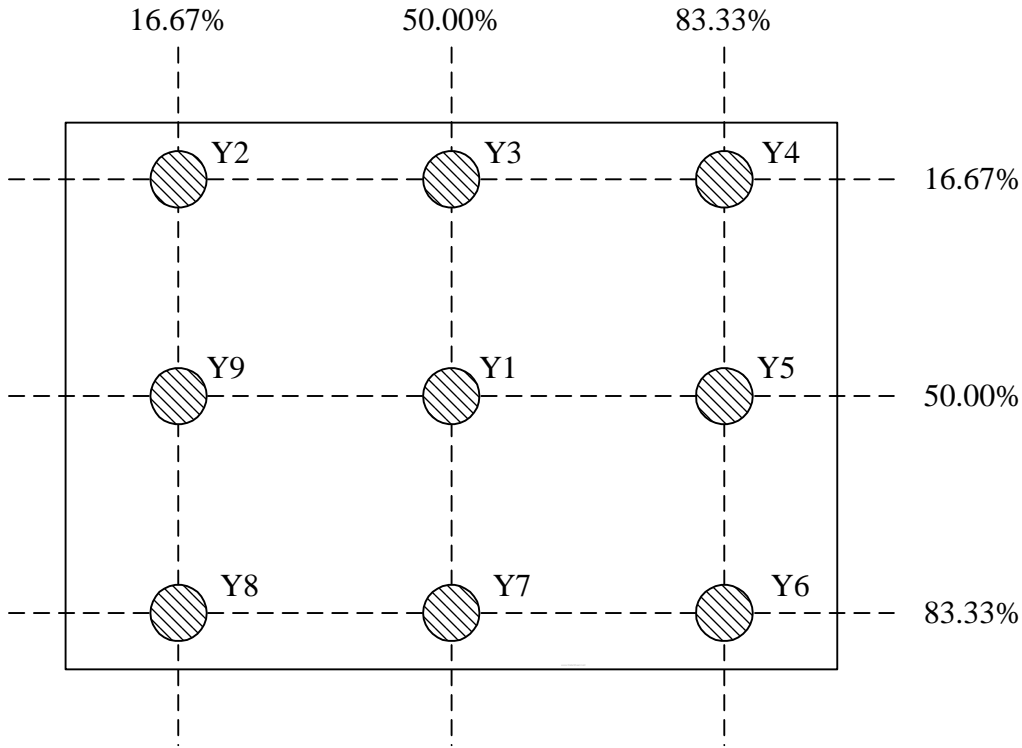

$$\text{Luminance uniformity} = \frac{(\text{Min Luminance of 9 points})}{(\text{Max Luminance of 9 points})} \times 100\%$$

**Note (6)** : Rubbing Direction (The different Rubbing Direction will cause the different optima view direction.)

Document Title	HSD100IXN1 Formal Standard Specification	Page No.	10/31
Document No.		Revision	1.0

## 4.0 BLOCK DIAGRAM

### 4.1 TFT LCD Module:

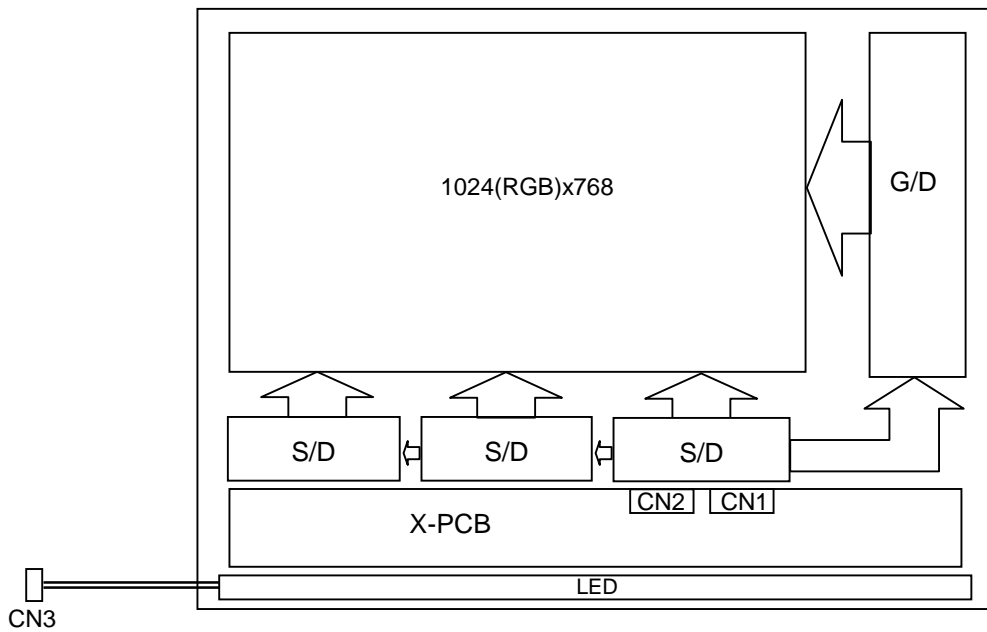

### 4.2 Pixel Format

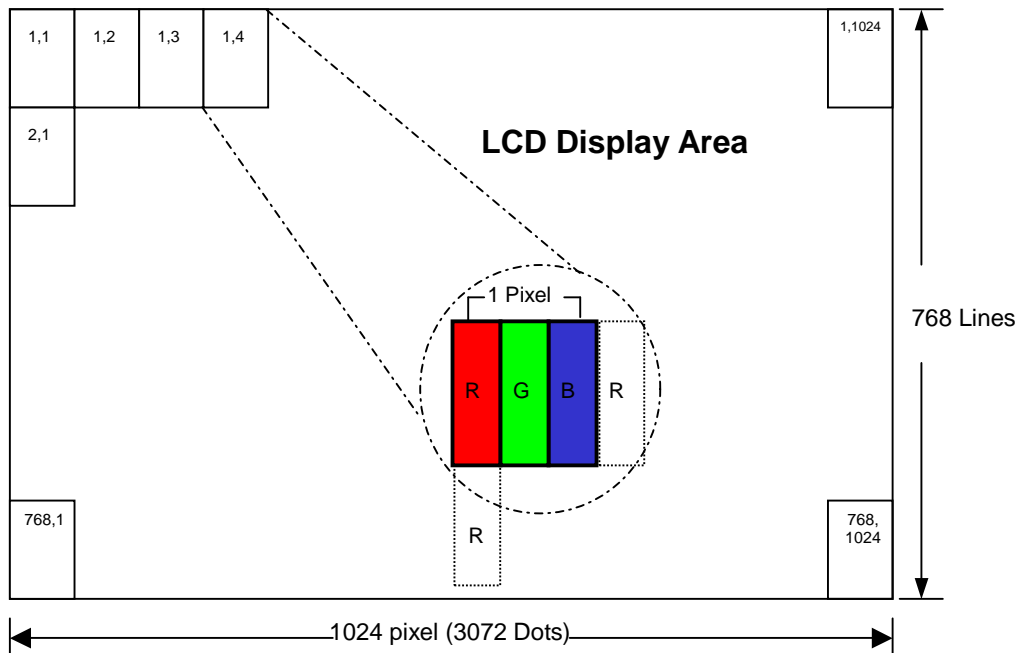

Document Title	HSD100IXN1 Formal Standard Specification	Page No.	11/31
Document No.		Revision	1.0

## 5.0 INTERFACE PIN CONNECTION

### 5.1 TFT LCD Module :

CN1 (Input signal): 30pin, 0.5mm pitch, 196033-30041-3 (P-TWO or equivalent)

Pin No.	Signal	Description
1	POL	Polarity Setting
2	STVD	Vertical Line start pulse I/O signal
3	OE123R	Vertical Line output Enable signal
4	G-CLKR	Vertical Line Clock
5	STVU	Vertical Line start pulse I/O signal
6	GND	Digital Power Ground
7	EDGSEL	Define clock edge select input, default EDGSEL=L. EDGSEL=L Latch data by rising edge of clock EDGSEL=H Latch data by rising and falling edges of clock
8	VCC	Digital Voltage Input
9	V9	Gamma Voltage Input
10	VGL	Gate OFF Voltage
11	V2	Gamma Voltage Input
12	VGH	Gate ON Voltage
13	V6	Gamma Voltage Input
14	UDC	Shift up/down control signal UDC = "H", up shift: STVD (Input) →G1 ~ G600→STVU (Output) UDC= "L", down shift: STVU (Input) →G600~G1→STVD (Output)
15	VCOM	Common Voltage
16	AGND	Analog Power Ground
17	AVDD	Analog Voltage Input
18	V14	Gamma Voltage Input
19	V11	Gamma Voltage Input
20	V8	Gamma Voltage Input
21	V5	Gamma Voltage Input
22	V3	Gamma Voltage Input
23	GND	Digital Power Ground
24	R5	Red Data Bus Input (MSB)
25	R4	Red Data Bus Input
26	R3	Red Data Bus Input
27	R2	Red Data Bus Input
28	R1	Red Data Bus Input
29	R0	Red Data Bus Input (LSB)
30	GND	Digital Power Ground

Document Title	HSD100IXN1 Formal Standard Specification	Page No.	12/31
Document No.		Revision	1.0

**CN2** (Input signal): 30pin, 0.5mm pitch, 196033-30041-3 (P-TWO or equivalent)

Pin No.	Signal	Description
1	GND	Digital Power Ground
2	G5	Green Data Bus Input (MSB)
3	G4	Green Data Bus Input
4	G3	Green Data Bus Input
5	G2	Green Data Bus Input
6	G1	Green Data Bus Input
7	G0	Green Data Bus Input (LSB)
8	DIO2_COF3	Horizontal Line start pulse I/O signal (STHR)
9	REV	Data Invert signal
10	GND	Digital Power Ground
11	CLK	Pixel clock
12	VCC	Digital Voltage Input
13	DIO1_COF1	Horizontal Line start pulse I/O signal (STHL)
14	LD	Polarity latch and re-flash new data to output
15	B5	Blue Data Bus Input (MSB)
16	B4	Blue Data Bus Input
17	B3	Blue Data Bus Input
18	B2	Blue Data Bus Input
19	B1	Blue Data Bus Input
20	B0	Blue Data Bus Input (LSB)
21	LRC	Select left or right shift, normally pulled high. SHL="1": DIO1→ OUT1,2,3→OUT4,5,6→ OUT1198,1199,1200 = DIO2 SHL="0": DIO1= OUT1,2,3 ← OUT4,5,6← OUT1198,1199,1200←DIO2
22	V1	Gamma Voltage Input
23	V4	Gamma Voltage Input
24	V7	Gamma Voltage Input
25	V10	Gamma Voltage Input
26	V12	Gamma Voltage Input
27	V13	Gamma Voltage Input
28	AVDD	Analog Voltage Input
29	AGND	Analog Power Ground
30	VCOM	Common Voltage

## 5.2 Back-Light Unit

CN3 LED Power Source (**BHSR-02VS-1**) or equivalent

Mating Connector: (**SBHT-002T-P0.5**) or equivalent

Terminal no.	Symbol	Function
1	V <sub>L</sub>	LED power supply (high voltage)
2	G <sub>L</sub>	LED power supply (low voltage)

Document Title	HSD100IXN1 Formal Standard Specification	Page No.	13/31
Document No.		Revision	1.0

## 6.0 ELECTRICAL CHARACTERISTICS

### 6.1 TFT LCD Module

Item	Symbol	Min.	Typ.	Max.	Unit	Note
Supply Voltage	V <sub>CC</sub>	3.0	3.3	3.6	V	Note (2), Note (3)
	V <sub>GH</sub>	16.55	17	17.45	V	Note (2), Note (3)
	V <sub>GL</sub>	-7.35	-7	-6.65	V	Note (2), Note (3)
	AV <sub>DD</sub>	9.22	9.48	9.75	V	Note (2), Note (3)
VCOM	V <sub>COMin</sub>	-	3.19	-	V	
Input signal voltage	V <sub>iH</sub>	0.7 V <sub>CC</sub>	-	V <sub>CC</sub>	V	Note (1)
	V <sub>iL</sub>	0	-	0.3 V <sub>CC</sub>	V	
Current of power supply	I <sub>CC</sub>	-	8.3	-	mA	V <sub>CC</sub> = 3.3V (Black)
	I <sub>ADD</sub>	-	70	-	mA	AV <sub>DD</sub> = 9.5 V (Black)
	I <sub>GH</sub>	-	0.3	-	mA	V <sub>GH</sub> = 17 V
	I <sub>GL</sub>	-	0.6	-	mA	V <sub>GL</sub> = -7 V
Input level of V1~V5	V <sub>X</sub>	AV <sub>DD</sub> /2	-	AV <sub>DD</sub> -0.1	V	
Input level of V6~V10	V <sub>X</sub>	0.1	-	AV <sub>DD</sub> /2	V	

Note (1): HSYNC, VSYNC, DE, Digital Data

Note (2): Be sure to apply the power voltage as the power sequence spec.

Note (3): DGND=AGND=0V

Document Title	HSD100IXN1 Formal Standard Specification	Page No.	14/31
Document No.		Revision	1.0

### 6.2 Back-Light Unit

The back-light system is an edge-lighting type with 33 LED.

The characteristics of the LED are shown in the following tables.

Item	Symbol	Min.	Typ.	Max.	Unit	Note
LED current	$I_L$	—	220	—	mA	(2)
LED voltage	$V_L$	—	10.5	—	V	
Operating LED life time	Hr	20000	—	—	Hour	(1)(2)

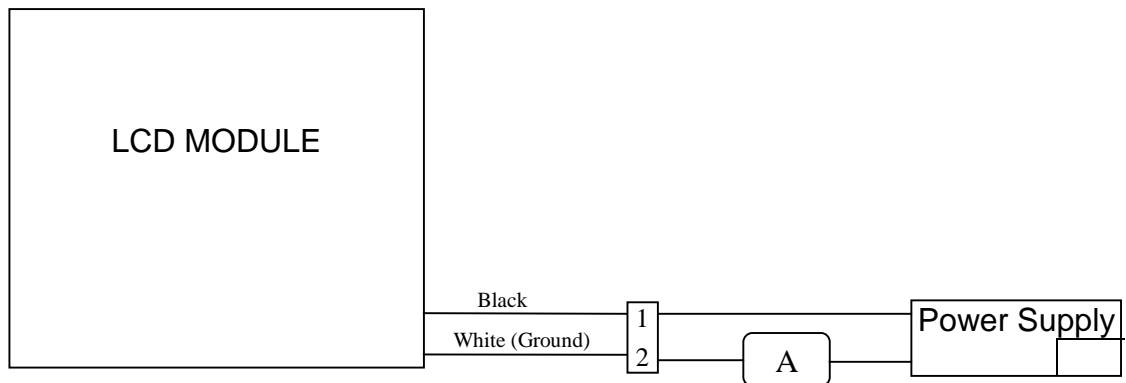

Note (1) LED life time (Hr) can be defined as the time in which it continues to operate under the condition:  $T_a=25\pm 3^\circ\text{C}$ , typical  $I_L$  value indicated in the above table until the brightness becomes less than 50%.

Note (2) The “LED life time” is defined as the module brightness decrease to 50% original brightness at  $T_a=25^\circ\text{C}$  and  $I_L=220\text{mA}$ . The LED lifetime could be decreased if operating  $I_L$  is larger than 220mA. The constant current driving method is suggested.

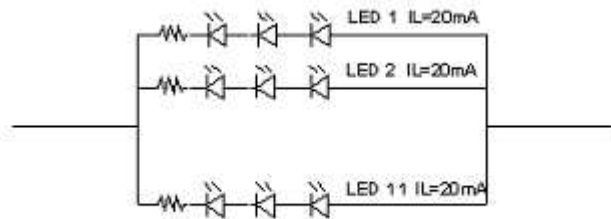

**LED Light Bar Circuit**

Document Title	HSD100IXN1 Formal Standard Specification	Page No.	15/31
Document No.		Revision	1.0

Note (3) Suggested Schematic of LED Back-Light Driver

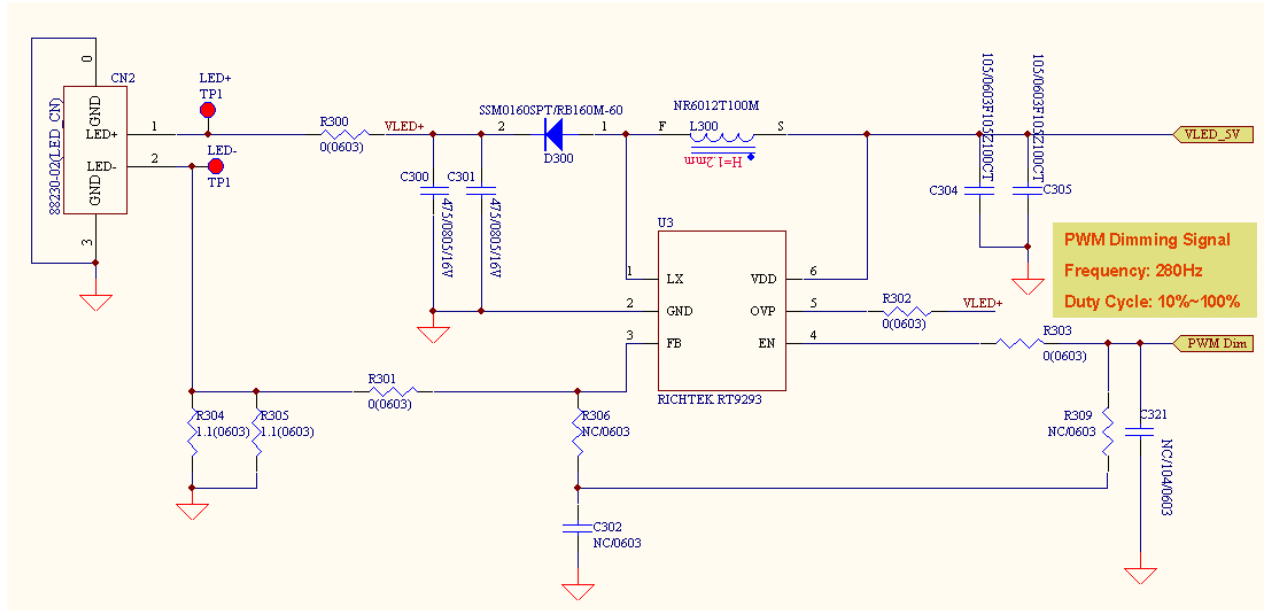

Suggested Schematic of LED Back-Light Driver

Document Title	HSD100IXN1 Formal Standard Specification	Page No.	16/31
Document No.		Revision	1.0

### 6.3 AC Characteristics

#### Source Driver Timing

Item	Symbol	Min.	Typ.	Max.	Unit	Note
CLK frequency	Fclk	-	56	60	MHz	-
CLK pulse width	Tcw	6	-	-	ns	-
Data set-up time	Tsu	4	-	-	ns	-
Data hold time	Thd	2	-	-	ns	-
Propagation delay of DIO2/1	Tphl	6	10	15	ns	CL=25pF ( Output )
Time that the last data to LD	Tld	1	-	-	Tcph	-
Pulse width of LD	Twld	2	-	-	Tcph	-
Time that LD to DIO1/2	Tlds	5	-	-	Tcph	-
POL set-up time	Tpsu	6	-	-	ns	POL to LD
POL hold time	Tphd	6	-	-	ns	POL to LD

#### Gate Driver Timing

Item	Symbol	Min.	Typ.	Max.	Unit	Note
CPV period	Tcpv	5	-	-	us	-
CPV pulse width	Tcpvh, Tcplv	2.5	-	-	us	50% duty cycle
OE pulse width	Twoe	1	-	-	us	-
Data setup time	Tsu	200	-	-	ns	-
Data hold time	Thd	300	-	-	ns	-



Document Title	HSD100IXN1 Formal Standard Specification	Page No.	17/31
Document No.		Revision	1.0

### 6.4 Timing Diagram of Interface Signal

#### Source Driver Timing

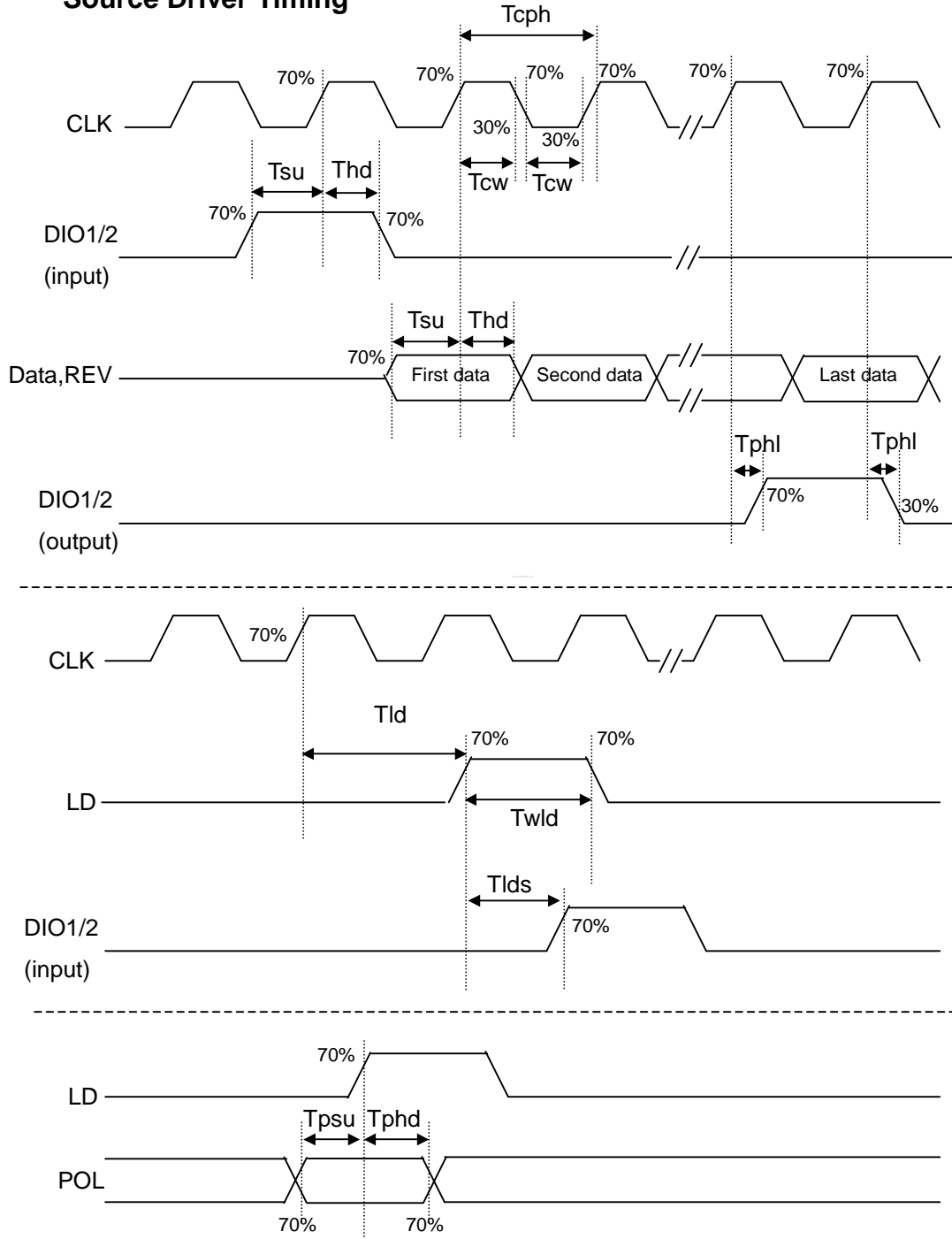

Document Title	HSD100IXN1 Formal Standard Specification	Page No.	18/31
Document No.		Revision	1.0

### Gate Driver Timing

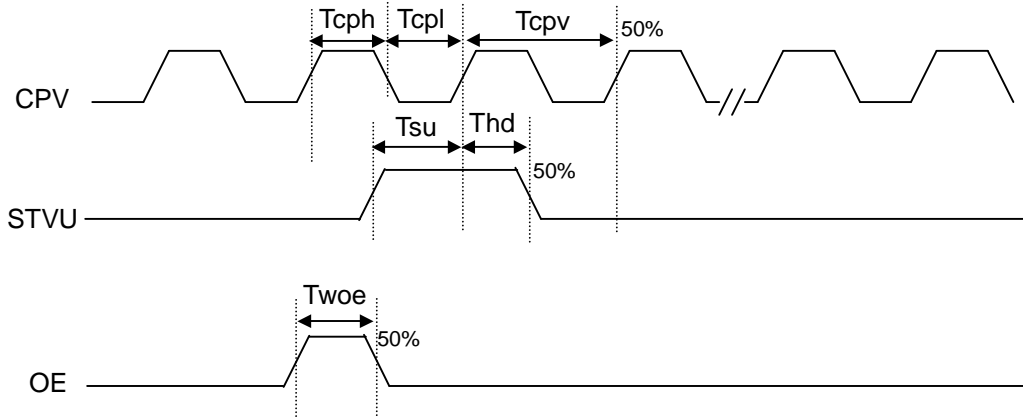

Document Title	HSD100IXN1 Formal Standard Specification	Page No.	19/31
Document No.		Revision	1.0

### 6.5 Power On / Off Sequence

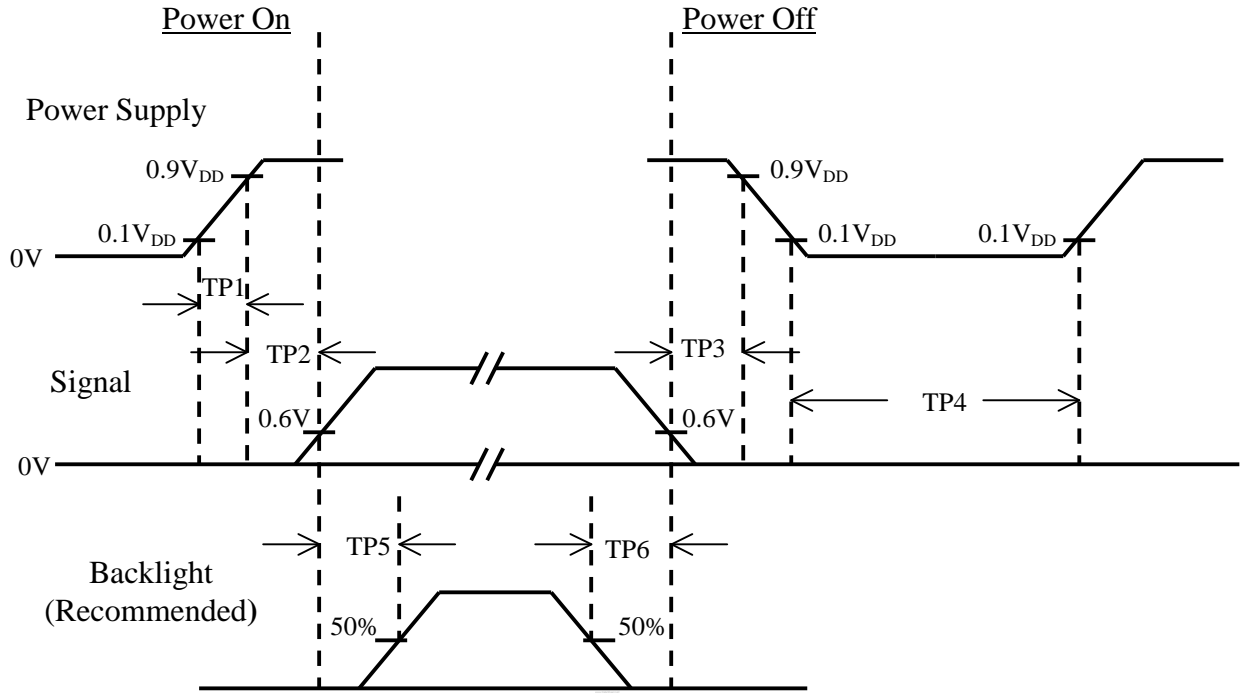

Item	Min.	Typ.	Max.	Unit	Remark
TP1	0.5	--	10	msec	
TP2	0	--	50	msec	
TP3	0	--	50	msec	
TP4	500	--	--	msec	
TP5	200	--	--	msec	
TP6	200	--	--	msec	

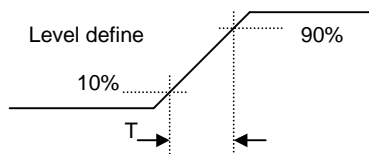

Power On Sequence: VCC-> AVDD -> VGL -> VGH -> Data -> B/L

Power Off Sequence: B/L-> Data -> VGH -> VGL -> AVDD -> VCC

Notes: Data include R0~R7, G0~G7, B0~B7, HSD, VSD, DCLK, SHLR, UPDN, DE MODE, RSTB, STBYB, SHLR, UPDN, DITH

Document Title	HSD100IXN1 Formal Standard Specification	Page No.	20/31
Document No.		Revision	1.0

### 6.6 Gamma circuit

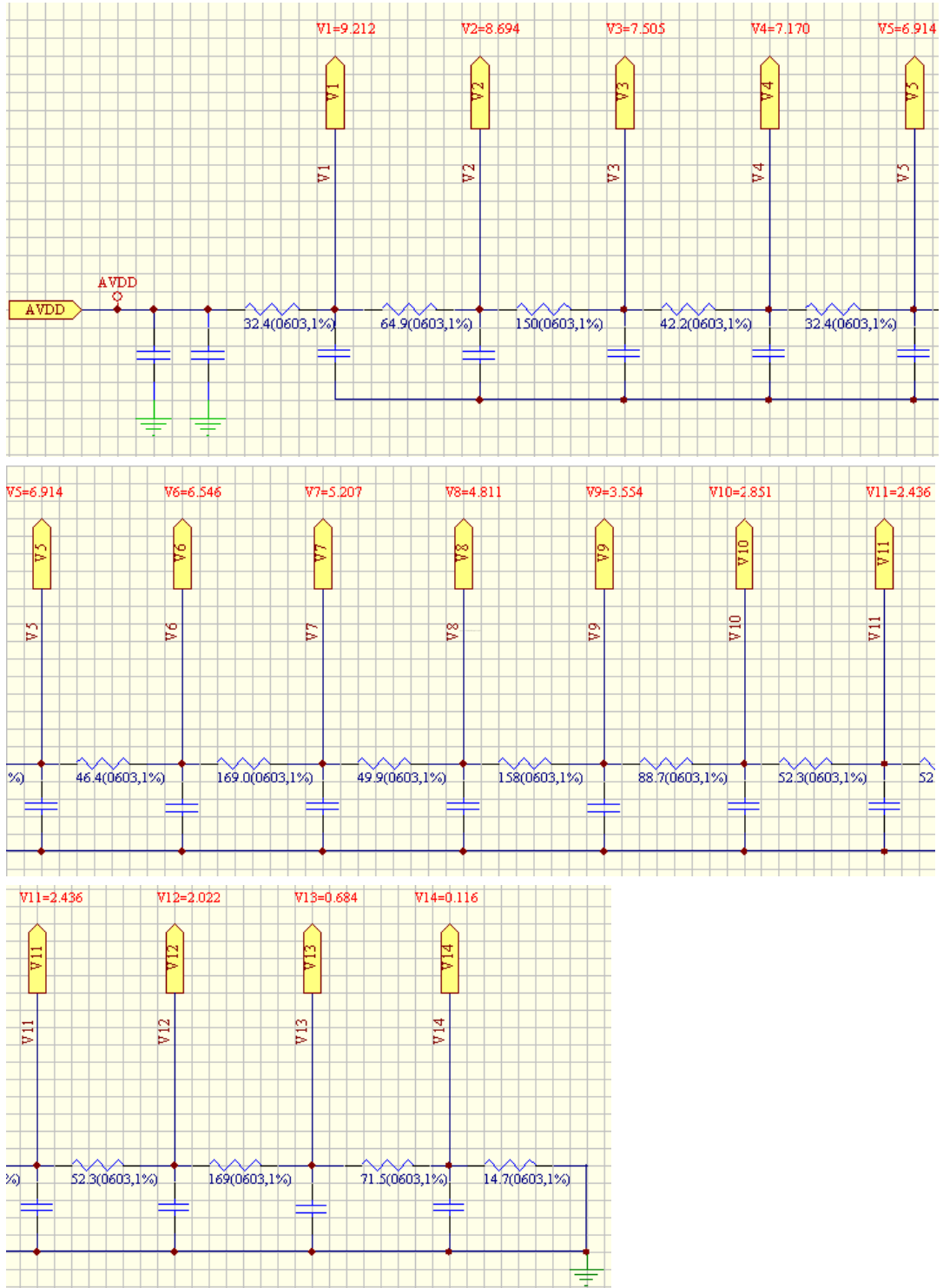

\*Suggested Gamma Circuit(AVDD=9.5V).

Document Title	HSD100IXN1 Formal Standard Specification	Page No.	21/31
Document No.		Revision	1.0

### 7.0 Reliability test items

No.	Item	Conditions	Remark
1	High Temperature Storage	Ta=+80°C, 240hrs	
2	Low Temperature Storage	Ta=-30°C, 240hrs	
3	High Temperature Operation	Ta=+70°C, 240hrs	
4	Low Temperature Operation	Ta=-20°C, 240hrs	
5	High Temperature and High Humidity (operation)	Ta=+60°C, 90%RH, 240hrs	
6	Thermal Cycling Test (non operation)	-30°C(30min) → +80°C(30min), 200cycles	
7	Electrostatic Discharge	±200V,200pF(0Ω) 1 time/each terminal	
8	Vibration	1.Random: 1.04Grms, 5~500Hz, X/Y/Z, 30min/each direction 2. Sine: Freq. Range: 8~33.3Hz Stoke: 1.3mm Sweep: 2.9G, 33.3~400Hz X/Z: 2hr, Y: 4hr, cyc: 15min	
9	Shock	100G, 6ms, ±X, ±Y, ±Z 3 time for each direction	JIS C7021, A-10 (Condition A)
10	Vibration (with carton)	Random: 0.015G <sup>2</sup> /Hz, 5~200Hz -6dB/Octave, 200~400Hz XYZ each direction: 2hr	
11	Drop (with carton)	Height: 60cm 1 corner, 3 edges, 6 surfaces	JIS Z0202

Note: There is no display function NG issue occurred, all the cosmetic specification is judged before the reliability stress.

Document Title	HSD100IXN1 Formal Standard Specification	Page No.	22/31
Document No.		Revision	1.0

## 8.0 OUTLINE DIMENSION

### 8.1 Outline Dimension

Unit : mm

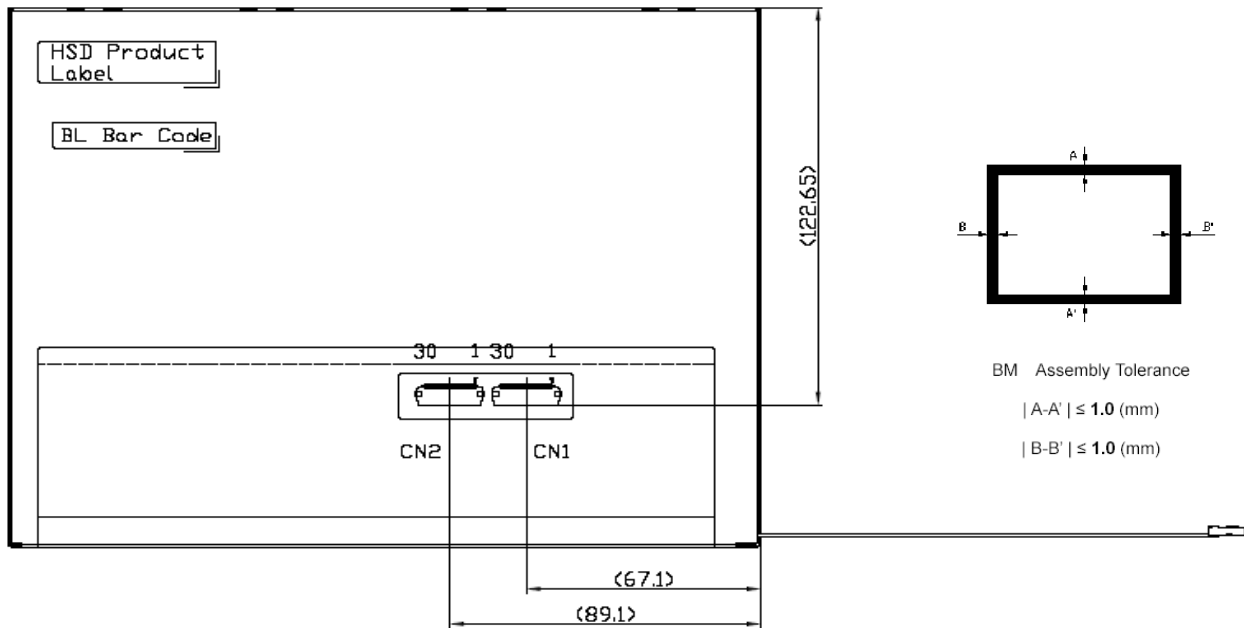
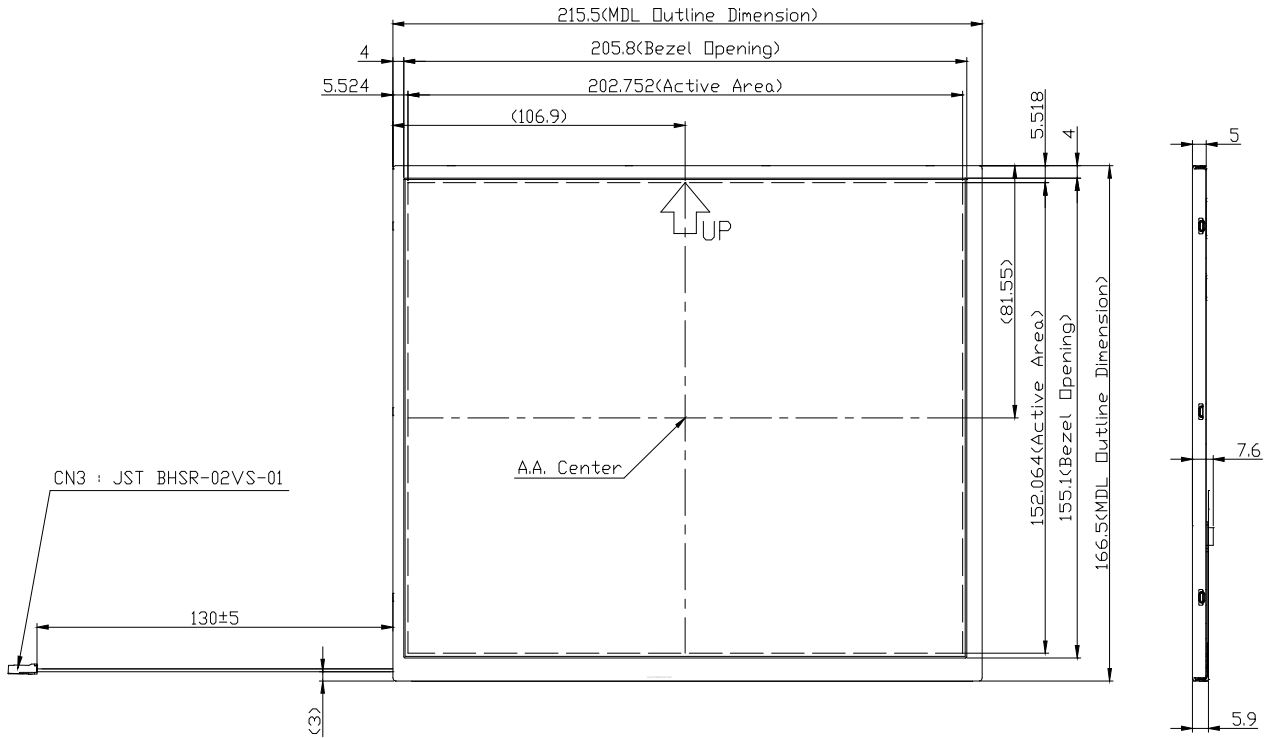

Note : General Tolerance : +/- 0.3mm

Document Title	HSD100IXN1 Formal Standard Specification	Page No.	23/31
Document No.		Revision	1.0

## 9.0 LOT MARK

### 9.1 Lot Mark

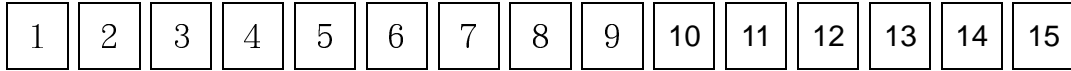

Code 1,2,3,4,5,6: HannStar internal flow control code.

Code 7: production location.

Code 8: production year.

Code 9: production month.

Code 10,11,12,13,14,15: serial number.

Note (1) Production Year: Code 8 is defined by the last number of the year, for example

Year	2006	2007	2008	2009	2010	2011	2012	2013	2014	2015
Mark	6	7	8	9	0	1	2	3	4	5

Note (2) Production Month

Month	Jan.	Feb.	Mar.	Apr.	May.	Jun.	Jul.	Aug.	Sep.	Oct	Nov.	Dec.
Mark	1	2	3	4	5	6	7	8	9	A	B	C

### 9.2 Detail of Lot Mark

- (1) Below label is attached on the backside of the LCD module. See Section 8.0: Outline Dimension.
- (2) The detail of Lot Mark is attached as below.
- (3) This is subject to change without prior notice.

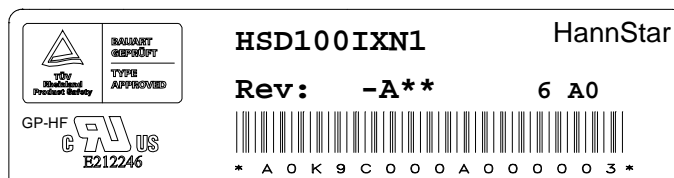

Document Title	HSD100IXN1 Formal Standard Specification	Page No.	24/31
Document No.		Revision	1.0

## 10.0 PACKAGE SPECIFICATION

### 10.1 Packing form

LCM Model	LCM Qty. in the box	Inner Box Size (mm)	Notice
HSD100IXN1-A	60 pcs/box	Ref.538 x 302 x 417 <sup>H</sup>	

### 10.2 Packing assembly drawings

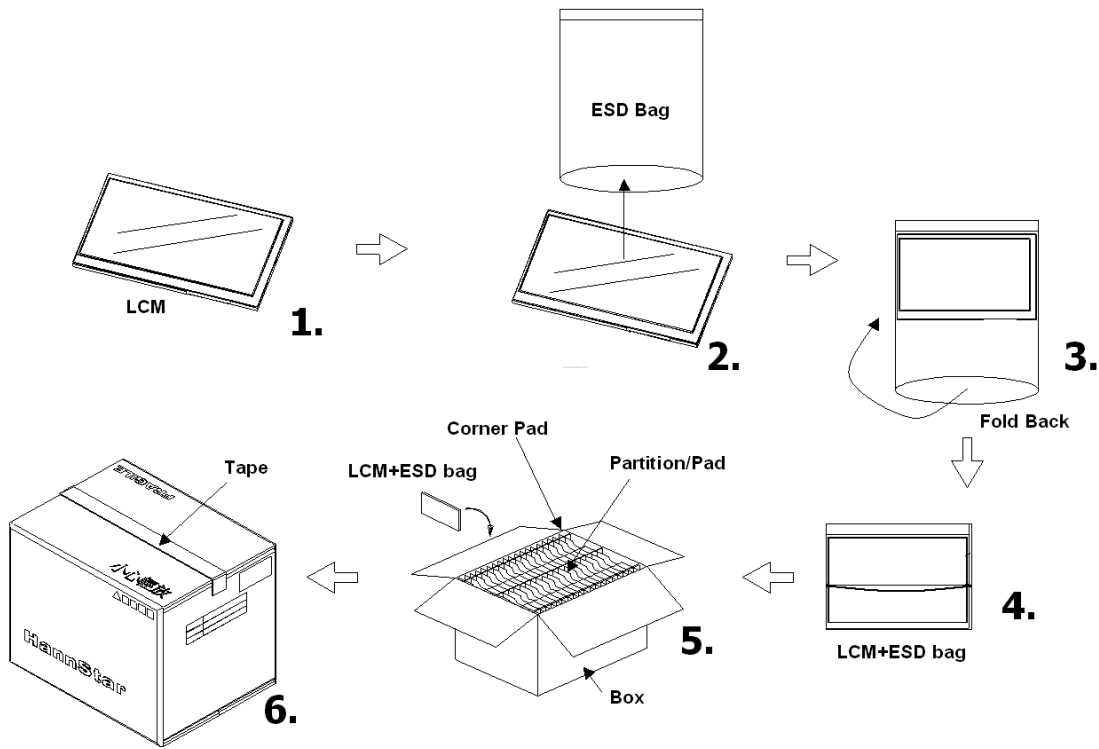

	Material	Notice
Box	Corrugated Paper Board	(AB Flute)
Partition/Pad	Corrugated Paper Board	(B Flute)
Corner Pad	Corrugated Paper Board	(AB Flute)
ESD bag	PE	





Document Title	HSD100IXN1 Formal Standard Specification	Page No.	25/31
Document No.		Revision	1.0

## 11.0 GENERAL PRECAUTION

### 11.1 Use Restriction

This product is not authorized for use in life supporting systems, aircraft navigation control systems, military systems and any other application where performance failure could be life-threatening or otherwise catastrophic.

### 11.2 Disassembling or Modification

Do not disassemble or modify the module. It may damage sensitive parts inside LCD module, and may cause scratches or dust on the display. HannStar does not warrant the module, if customers disassemble or modify the module.

### 11.3 Breakage of LCD Panel

11.3.1. If LCD panel is broken and liquid crystal spills out, do not ingest or inhale liquid crystal, and do not contact liquid crystal with skin.

11.3.2. If liquid crystal contacts mouth or eyes, rinse out with water immediately.

11.3.3. If liquid crystal contacts skin or cloths, wash it off immediately with alcohol and rinse thoroughly with water.

11.3.4. Handle carefully with chips of glass that may cause injury, when the glass is broken.

### 11.4 Electric Shock

11.4.1. Disconnect power supply before handling LCD module.

11.4.2. Do not pull or fold the LED cable.

11.4.3. Do not touch the parts inside LCD modules and the fluorescent LED's connector or cables in order to prevent electric shock.

### 11.5 Absolute Maximum Ratings and Power Protection Circuit

11.5.1. Do not exceed the absolute maximum rating values, such as the supply voltage variation, input voltage variation, variation in parts' parameters, environmental temperature, etc., otherwise LCD module may be damaged.

11.5.2. Please do not leave LCD module in the environment of high humidity and high temperature for a long time.

11.5.3. It's recommended to employ protection circuit for power supply.

### 11.6 Operation

11.6.1 Do not touch, push or rub the polarizer with anything harder than HB pencil lead.

11.6.2 Use fingerstalls of soft gloves in order to keep clean display quality, when persons handle the LCD module for incoming inspection or assembly.

11.6.3 When the surface is dusty, please wipe gently with absorbent cotton or other soft material.



Document Title	HSD100IXN1 Formal Standard Specification	Page No.	26/31
Document No.		Revision	1.0

11.6.4 Wipe off saliva or water drops as soon as possible. If saliva or water drops contact with polarizer for a long time, they may causes deformation or color fading.

11.6.5 When cleaning the adhesives, please use absorbent cotton wetted with a little petroleum benzine or other adequate solvent.

**11.7 Mechanism**

Please mount LCD module by using mounting holes arranged in four corners tightly.

**11.8 Static Electricity**

11.8.1 Protection film must remove very slowly from the surface of LCD module to prevent from electrostatic occurrence.

11.8.2 Because LCD module use CMOS-IC on circuit board and TFT-LCD panel, it is very weak to electrostatic discharge. Please be careful with electrostatic discharge. Persons who handle the module should be grounded through adequate methods.

**11.9 Strong Light Exposure**

The module shall not be exposed under strong light such as direct sunlight. Otherwise, display characteristics may be changed.

**11.10 Disposal**

When disposing LCD module, obey the local environmental regulations.

Document Title	HSD100IXN1 Formal Standard Specification	Page No.	27/31
Document No.		Revision	1.0

## HSD100IXN1-A10

### 3.1 Optical specification

Item		Symbol	Condition	Min.	Typ.	Max.	Unit	Note	
Contrast		CR	$\theta=0$ Normal viewing angle	480	600	—		(1)(2)	
Response time	Rising	$T_R$		—	2.4	4.8	msec	(1)(3)	
	Falling	$T_F$		—	5.6	11.2			
White luminance (Center)		$Y_L$			200	250	—	cd/m <sup>2</sup>	(1)(4) ( $I_L=120mA$ )
Color gamut		S			—	60	—	%	
Color chromaticity (CIE1931)	White	$W_x$			0.280	0.310	0.340		(1)(4)
		$W_y$			0.300	0.330	0.360		
	Red	$R_x$			0.579	0.609	0.639		
		$R_y$			0.326	0.356	0.386		
	Green	$G_x$			0.289	0.319	0.349		
		$G_y$		0.557	0.587	0.617			
	Blue	$B_x$		0.124	0.154	0.184			
		$B_y$		0.056	0.086	0.116			
Viewing angle	Hor.	$\theta_L$	$CR>10$	65	75	—			
		$\theta_R$		65	75	—			
	Ver.	$\theta_U$		50	60	—			
		$\theta_D$		60	70	—			
Brightness uniformity		$B_{UNI}$	$\theta=0$	70	—	—	%	(5)	
Optima View Direction		6 O' clock						(6)	

Document Title	HSD100IXN1 Formal Standard Specification	Page No.	28/31
Document No.		Revision	1.0

### 5.3 TFT LCD Module :

CN (Input signal): 60pin, 0.5mm pitch, 106C60-102000-G2-R (Starconn or equivalent)

Pin No.	Signal	Description
1	POL	Polarity Setting
2	STVD	Vertical Line start pulse I/O signal
3	OE123R	Vertical Line output Enable signal
4	G-CLKR	Vertical Line Clock
5	STVU	Vertical Line start pulse I/O signal
6	GND	Digital Power Ground
7	EDGSEL	Define clock edge select input, default EDGSEL=L. EDGSEL=L Latch data by rising edge of clock EDGSEL=H Latch data by rising and falling edges of clock
8	VCC	Digital Voltage Input
9	V9	Gamma Voltage Input
10	VGL	Gate OFF Voltage
11	V2	Gamma Voltage Input
12	VGH	Gate ON Voltage
13	V6	Gamma Voltage Input
14	UDC	Shift up/down control signal UDC = "H", up shift: STVD (Input) →G1 ~ G600→STVU (Output) UDC= "L", down shift: STVU (Input) →G600~G1→STVD (Output)
15	VCOM	Common Voltage
16	AGND	Analog Power Ground
17	AVDD	Analog Voltage Input
18	V14	Gamma Voltage Input
19	V11	Gamma Voltage Input
20	V8	Gamma Voltage Input
21	V5	Gamma Voltage Input
22	V3	Gamma Voltage Input
23	GND	Digital Power Ground
24	R5	Red Data Bus Input (MSB)
25	R4	Red Data Bus Input
26	R3	Red Data Bus Input
27	R2	Red Data Bus Input
28	R1	Red Data Bus Input
29	R0	Red Data Bus Input (LSB)
30	GND	Digital Power Ground

Document Title	HSD100IXN1 Formal Standard Specification	Page No.	29/31
Document No.		Revision	1.0

Pin No.	Signal	Description
31	GND	Digital Power Ground
32	G5	Green Data Bus Input (MSB)
33	G4	Green Data Bus Input
34	G3	Green Data Bus Input
35	G2	Green Data Bus Input
36	G1	Green Data Bus Input
37	G0	Green Data Bus Input (LSB)
38	DIO2_COF3	Horizontal Line start pulse I/O signal (STHR)
39	REV	Data Invert signal
40	GND	Digital Power Ground
41	CLK	Pixel clock
42	VCC	Digital Voltage Input
43	DIO1_COF1	Horizontal Line start pulse I/O signal (STHL)
44	LD	Polarity latch and re-flash new data to output
45	B5	Blue Data Bus Input (MSB)
46	B4	Blue Data Bus Input
47	B3	Blue Data Bus Input
48	B2	Blue Data Bus Input
49	B1	Blue Data Bus Input
50	B0	Blue Data Bus Input (LSB)
51	LRC	Select left or right shift, normally pulled high. SHL="1": DIO1→ OUT1,2,3→OUT4,5,6→ OUT1198,1199,1200 = DIO2 SHL="0": DIO1= OUT1,2,3 ← OUT4,5,6← OUT1198,1199,1200←DIO2
52	V1	Gamma Voltage Input
53	V4	Gamma Voltage Input
54	V7	Gamma Voltage Input
55	V10	Gamma Voltage Input
56	V12	Gamma Voltage Input
57	V13	Gamma Voltage Input
58	AVDD	Analog Voltage Input
59	AGND	Analog Power Ground
60	VCOM	Common Voltage

### 6.6 Back-Light Unit

The back-light system is an edge-lighting type with 33 LED.

The characteristics of the LED are shown in the following tables.

Item	Symbol	Min.	Typ.	Max.	Unit	Note
LED current	I <sub>L</sub>	—	220	—	mA	(2)
LED voltage	V <sub>L</sub>	—	10.5	11	V	
Operating LED life time	Hr	20000	—	—	Hour	(1)(2)

Document Title	HSD100IXN1 Formal Standard Specification	Page No.	30/31
Document No.		Revision	1.0

### Source Driver Timing

Item	Symbol	Min.	Typ.	Max.	Unit	Note
CLK frequency	Fclk	48	56	60	MHz	Frame rate at 60Hz
CLK pulse width	Tcw	6	-	-	ns	-
Data set-up time	Tsu	4	-	-	ns	-
Data hold time	Thd	2	-	-	ns	-
Propagation delay of DIO2/1	Tphl	6	10	15	ns	CL=25pF ( Output )
Time that the last data to LD	Tld	1	-	-	Tcph	-
Pulse width of LD	Twld	2	-	-	Tcph	-
Time that LD to DIO1/2	Tlds	5	-	-	Tcph	-
POL set-up time	Tpsu	6	-	-	ns	POL to LD
POL hold time	Tphd	6			ns	POL to LD

### Gate Driver Timing

Item	Symbol	Min.	Typ.	Max.	Unit	Note
CPV period	Tcpv	5	-	-	us	-
CPV pulse width	Tcpvh, Tcplv	2.5	-	-	us	50% duty cycle
OE pulse width	Twoe	1	-	-	us	-
Data setup time	Tsu	200	-	-	ns	-
Data hold time	Thd	300	-	-	ns	-

Document Title	HSD100IXN1 Formal Standard Specification	Page No.	31/31
Document No.		Revision	1.0

### 8.1 Outline Dimension

