

Integrated Device Technology, Inc.

CMOS ASYNCHRONOUS FIFO

2048 x 9, 4096 x 9,
8192 x 9 and 16384 x 9

IDT7203
IDT7204
IDT7205
IDT7206

FEATURES:

- First-In/First-Out Dual-Port memory
- 2048 x 9 organization (IDT7203)
- 4096 x 9 organization (IDT7204)
- 8192 x 9 organization (IDT7205)
- 16384 x 9 organization (IDT7206)
- High-speed: 12ns access time
- Low power consumption
 - Active: 770mW (max.)
 - Power-down: 44mW (max.)
- Asynchronous and simultaneous read and write
- Fully expandable in both word depth and width
- Pin and functionally compatible with IDT720X family
- Status Flags: Empty, Half-Full, Full
- Retransmit capability
- High-performance CMOS technology
- Military product compliant to MIL-STD-883, Class B
- Standard Military Drawing for #5962-88669 (IDT7203), 5962-89567 (IDT7203), and 5962-89568 (IDT7204) are listed on this function.

DESCRIPTION:

The IDT7203/7204/7205/7206 are dual-port memory buffers with internal pointers that load and empty data on a first-in/first-out basis. The device uses Full and Empty flags to prevent data overflow and underflow and expansion logic to allow for unlimited expansion capability in both word size and depth.

Data is toggled in and out of the device through the use of the Write (\bar{W}) and Read (\bar{R}) pins.

The devices 9-bit width provides a bit for a control or parity at the user's option. It also features a Retransmit (\bar{RT}) capability that allows the read pointer to be reset to its initial position when \bar{RT} is pulsed LOW. A Half-Full Flag is available in the single device and width expansion modes.

The IDT7203/7204/7205/7206 are fabricated using IDT's high-speed CMOS technology. They are designed for applications requiring asynchronous and simultaneous read/writes in multiprocessing, rate buffering, and other applications.

Military grade product is manufactured in compliance with the latest revision of MIL-STD-883, Class B.

FUNCTIONAL BLOCK DIAGRAM

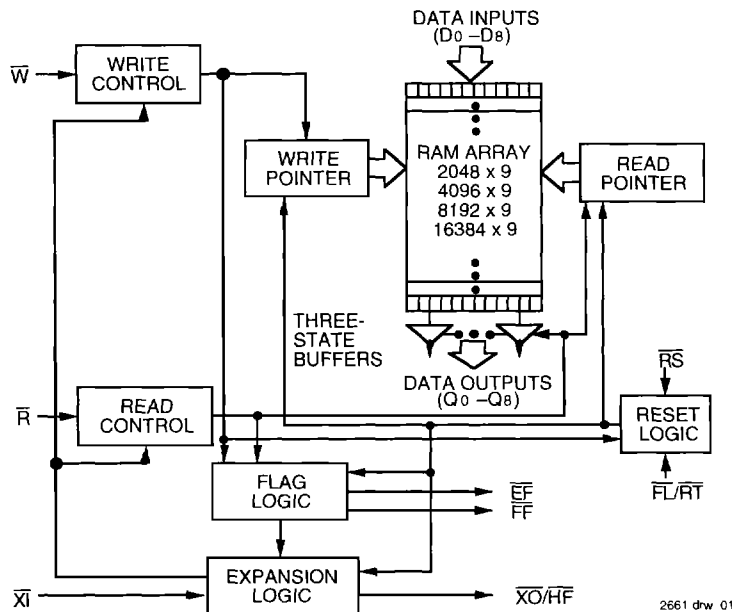

The IDT logo is a registered trademark of Integrated Device Technology, Inc.

MILITARY AND COMMERCIAL TEMPERATURE RANGES

AUGUST 1994

PIN CONFIGURATIONS

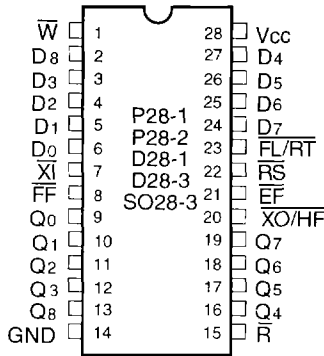

2661 drw 02a

**DIP
TOP VIEW**

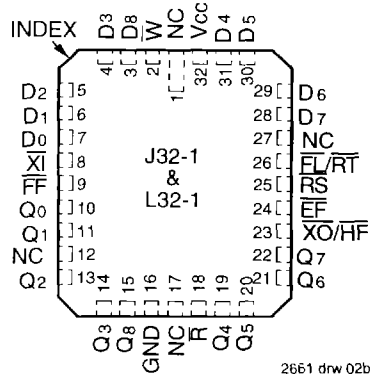

2661 drw 02b

**PLCC/LCC
TOP VIEW**

NOTES:

1. The THINDIPs P28-2 and D28-3 are only available for the 7203/7204/7205.
2. The small outline package SO28-3 is only available for the 7204.
3. Consult factory for CERPACK pinout.



ABSOLUTE MAXIMUM RATINGS⁽¹⁾

Symbol	Rating	Commercial	Military	Unit
VTERM	Terminal Voltage with Respect to GND	-0.5 to +7.0	-0.5 to +7.0	V
TA	Operating Temperature	0 to +70	-55 to +125	° C
TBIAS	Temperature Under Bias	-55 to +125	-65 to +135	° C
TSTG	Storage Temperature	-55 to +125	-65 to +155	° C
IOUT	DC Output Current	50	50	mA

NOTE:

2661 tbl 01

1. Stresses greater than those listed under ABSOLUTE MAXIMUM RATINGS may cause permanent damage to the device. This is a stress rating only and functional operation of the device at these or any other conditions above those indicated in the operation! sections of this specification is not implied. Exposure to absolute maximum rating conditions for extended periods may affect reliability.

RECOMMENDED DC OPERATING CONDITIONS

Symbol	Parameter	Min.	Typ.	Max.	Unit
VCCM	Military Supply Voltage	4.5	5.0	5.5	V
VCCC	Commercial Supply Voltage	4.5	5.0	5.5	V
GND	Supply Voltage	0	0	0	V
VIH ⁽¹⁾	Input High Voltage Commercial	2.0	—	—	V
VIH ⁽¹⁾	Input High Voltage Military	2.2	—	—	V
VIL ⁽¹⁾	Input Low Voltage Commercial and Military	—	—	0.8	V

NOTE:

2661 tbl 02

1. 1.5V undershoots are allowed for 10ns once per cycle.

DC ELECTRICAL CHARACTERISTICS FOR THE 7203 AND 7204

(Commercial: $V_{CC} = 5.0V \pm 10\%$, $T_A = 0^\circ C$ to $+70^\circ C$; Military: $V_{CC} = 5.0V \pm 10\%$, $T_A = -55^\circ C$ to $+125^\circ C$)

Symbol	Parameter	IDT7203/7204 Commercial $t_A = 12, 15, 20, 25, 35, 50$ ns			IDT7203/7204 Military ⁽¹⁾ $t_A = 20, 30, 40, 50, 65, 80, 120$ ns			Unit
		Min.	Typ.	Max.	Min.	Typ.	Max.	
		$I_{L1}^{(2)}$	Input Leakage Current (Any Input)	-1	—	1	-1	
$I_{L0}^{(3)}$	Output Leakage Current	-10	—	10	-10	—	10	μA
V_{OH}	Output Logic "1" Voltage $I_{OH} = -2mA$	2.4	—	—	2.4	—	—	V
V_{OL}	Output Logic "0" Voltage $I_{OL} = 8mA$	—	—	0.4	—	—	0.4	V
$I_{CC1}^{(4)}$	Active Power Supply Current	—	—	120 ⁽⁵⁾	—	—	150 ⁽⁵⁾	mA
$I_{CC2}^{(4)}$	Standby Current ($\overline{R}=\overline{W}=\overline{RS}=\overline{FL}/\overline{RT}=V_{IH}$)	—	—	12	—	—	25	mA
$I_{CC3(L)}^{(4)}$	Power Down Current (All Input = $V_{CC} - 0.2V$)	—	—	2	—	—	4	mA
$I_{CC3(S)}^{(4)}$	Power Down Current (All Input = $V_{CC} - 0.2V$)	—	—	8	—	—	12	mA

NOTES:

- Speed grades 65, 80, and 120ns are only available in the ceramic DIP.
- Measurements with $0.4 \leq V_{IN} \leq V_{CC}$.
- $R \geq V_{IH}$, $0.4 \leq V_{OUT} \leq V_{CC}$.
- I_{CC} measurements are made with outputs open (only capacitive loading).
- Tested at $f = 20MHz$.

2661 tbr 03

DC ELECTRICAL CHARACTERISTICS FOR THE 7205 AND 7206

(Commercial: $V_{CC} = 5.0V \pm 10\%$, $T_A = 0^\circ C$ to $+70^\circ C$; Military: $V_{CC} = 5.0V \pm 10\%$, $T_A = -55^\circ C$ to $+125^\circ C$)

Symbol	Parameter	IDT7205/7206 Commercial $t_A = 15, 20, 25, 35, 50$ ns			IDT7205/7206 Military $t_A = 20, 30, 50$ ns			Unit
		Min.	Typ.	Max.	Min.	Typ.	Max.	
		$I_{L1}^{(1)}$	Input Leakage Current (Any Input)	-1	—	1	-1	
$I_{L0}^{(2)}$	Output Leakage Current	-10	—	10	-10	—	10	μA
V_{OH}	Output Logic "1" Voltage $I_{OH} = -2mA$	2.4	—	—	2.4	—	—	V
V_{OL}	Output Logic "0" Voltage $I_{OL} = 8mA$	—	—	0.4	—	—	0.4	V
$I_{CC1}^{(3)}$	Active Power Supply Current	—	—	120 ⁽⁴⁾	—	—	150 ⁽⁴⁾	mA
$I_{CC2}^{(3)}$	Standby Current ($\overline{R}=\overline{W}=\overline{RS}=\overline{FL}/\overline{RT}=V_{IH}$)	—	—	12	—	—	25	mA
$I_{CC3(L)}^{(3)}$	Power Down Current (All Input = $V_{CC} - 0.2V$)	—	—	8	—	—	12	mA

NOTES:

- Measurements with $0.4 \leq V_{IN} \leq V_{CC}$.
- $R \geq V_{IH}$, $0.4 \leq V_{OUT} \leq V_{CC}$.
- I_{CC} measurements are made with outputs open (only capacitive loading).
- Tested at $f = 20MHz$.

2661 tbr 04

AC ELECTRICAL CHARACTERISTICS⁽¹⁾

(Commercial: VCC = 5V ± 10%, TA = 0°C to +70°C; Military: VCC = 5V ± 10%, TA = -55°C to +125°C)

Symbol	Parameters	Commercial		Com'l & Mil.		Com'l		Military		Com'l		Unit		
		7203S/L12 7204S/L12		7203S/L15 7204S/L15 7205L15 7206L15		7203S/L20 7204S/L20 7205L20 7206L20		7203S/L25 7204S/L25 7205L25 7206L25		7203S/L30 7204S/L30 7205L30 7206L30			7203S/L35 7204S/L35 7205L35 7206L35	
		Min.	Max.	Min.	Max.	Min.	Max.	Min.	Max.	Min.	Max.		Min.	Max.
fs	Shift Frequency	—	50	—	40	—	33.3	—	28.5	—	25	—	22.2	MHz
tRC	Read Cycle Time	20	—	25	—	30	—	35	—	40	—	45	—	ns
tA	Access Time	—	12	—	15	—	20	—	25	—	30	—	35	ns
tRR	Read Recovery Time	8	—	10	—	10	—	10	—	10	—	10	—	ns
tRPW	Read Pulse Width ⁽²⁾	12	—	15	—	20	—	25	—	30	—	35	—	ns
tRLZ	Read LOW to Data Bus LOW ⁽³⁾	3	—	5	—	5	—	5	—	5	—	5	—	ns
tWLZ	Write HIGH to Data Bus Low-Z ^(3, 4)	3	—	5	—	5	—	5	—	5	—	10	—	ns
tDV	Data Valid from Read HIGH	5	—	5	—	5	—	5	—	5	—	5	—	ns
tRHZ	Read HIGH to Data Bus High-Z ⁽³⁾	—	12	—	15	—	15	—	18	—	20	—	20	ns
tWC	Write Cycle Time	20	—	25	—	30	—	35	—	40	—	45	—	ns
tWPW	Write Pulse Width ⁽²⁾	12	—	15	—	20	—	25	—	30	—	35	—	ns
tWR	Write Recovery Time	8	—	10	—	10	—	10	—	10	—	10	—	ns
tDS	Data Set-up Time	9	—	11	—	12	—	15	—	18	—	18	—	ns
tDH	Data Hold Time	0	—	0	—	0	—	0	—	0	—	0	—	ns
tRSC	Reset Cycle Time	20	—	25	—	30	—	35	—	40	—	45	—	ns
tRS	Reset Pulse Width ⁽²⁾	12	—	15	—	20	—	25	—	30	—	35	—	ns
tRSS	Reset Set-up Time ⁽³⁾	12	—	15	—	20	—	25	—	30	—	35	—	ns
tRTR	Reset Recovery Time	8	—	10	—	10	—	10	—	10	—	10	—	ns
tRTC	Retransmit Cycle Time	20	—	25	—	30	—	35	—	40	—	45	—	ns
tRT	Retransmit Pulse Width ⁽²⁾	12	—	15	—	20	—	25	—	30	—	35	—	ns
tRTS	Retransmit Set-up Time ⁽³⁾	12	—	15	—	20	—	25	—	30	—	35	—	ns
tRSR	Retransmit Recovery Time	8	—	10	—	10	—	10	—	10	—	10	—	ns
tEFL	Reset to \overline{EF} LOW	—	12	—	25	—	30	—	35	—	40	—	45	ns
tHFH, tFFH	Reset to \overline{HF} and \overline{FF} HIGH	—	17	—	25	—	30	—	35	—	40	—	45	ns
tRTF	Retransmit LOW to Flags Valid	—	20	—	25	—	30	—	35	—	40	—	45	ns
tREF	Read LOW to \overline{EF} LOW	—	12	—	15	—	20	—	25	—	30	—	30	ns
tRFF	Read HIGH to \overline{FF} HIGH	—	14	—	15	—	20	—	25	—	30	—	30	ns
tRPE	Read Pulse Width after \overline{EF} HIGH	12	—	15	—	20	—	25	—	30	—	35	—	ns
tWEF	Write HIGH to \overline{EF} HIGH	—	12	—	15	—	20	—	25	—	30	—	30	ns
tWFF	Write LOW to \overline{FF} LOW	—	14	—	15	—	20	—	25	—	30	—	30	ns
tWHF	Write LOW to \overline{HF} Flag LOW	—	17	—	25	—	30	—	35	—	40	—	45	ns
tRHF	Read HIGH to \overline{HF} Flag HIGH	—	17	—	25	—	30	—	35	—	40	—	45	ns
tWPF	Write Pulse Width after \overline{FF} HIGH	12	—	15	—	20	—	25	—	30	—	35	—	ns
txOL	Read/Write LOW to \overline{XO} LOW	—	12	—	15	—	20	—	25	—	30	—	35	ns
txOH	Read/Write HIGH to \overline{XO} HIGH	—	12	—	15	—	20	—	25	—	30	—	35	ns
txI	\overline{XI} Pulse Width ⁽²⁾	12	—	15	—	20	—	25	—	30	—	35	—	ns
txIR	\overline{XI} Recovery Time	8	—	10	—	10	—	10	—	10	—	10	—	ns
txIS	\overline{XI} Set-up Time	8	—	10	—	10	—	10	—	10	—	15	—	ns

NOTES:

1. Timings referenced as in AC Test Conditions.
2. Pulse widths less than minimum are not allowed.
3. Values guaranteed by design, not currently tested.
4. Only applies to read data flow-through mode.

2661 tbr 05

AC ELECTRICAL CHARACTERISTICS⁽¹⁾ (Continued)

(Commercial: VCC = 5V ± 10%, TA = 0°C to +70°C; Military: VCC = 5V ± 10%, TA = -55°C to +125°C)

Symbol	Parameters	Military		Com'l & Mil.		Military ⁽²⁾						Unit
		7203S/L40 7204S/L40		7203S/L50 7204S/L50 7205L50 7206L50		7203S/L65 7204S/L65		7203S/L80 7204S/L80		7203S/L120 7204S/L120		
		Min.	Max.	Min.	Max.	Min.	Max.	Min.	Max.	Min.	Max.	
fs	Shift Frequency	—	20	—	15	—	12.5	—	10	—	7	MHz
tRC	Read Cycle Time	50	—	65	—	80	—	100	—	140	—	ns
tA	Access Time	—	40	—	50	—	65	—	80	—	120	ns
tRR	Read Recovery Time	10	—	15	—	15	—	20	—	20	—	ns
tRPW	Read Pulse Width ⁽³⁾	40	—	50	—	65	—	80	—	120	—	ns
tRLZ	Read LOW to Data Bus LOW ⁽⁴⁾	5	—	10	—	10	—	10	—	10	—	ns
tWLZ	Write HIGH to Data Bus Low-Z ^(4, 5)	10	—	15	—	15	—	20	—	20	—	ns
tDV	Data Valid from Read HIGH	5	—	5	—	5	—	5	—	5	—	ns
tRHZ	Read HIGH to Data Bus High-Z ⁽⁴⁾	—	25	—	30	—	30	—	30	—	35	ns
tWC	Write Cycle Time	50	—	65	—	80	—	100	—	140	—	ns
tWPW	Write Pulse Width ⁽³⁾	40	—	50	—	65	—	80	—	120	—	ns
tWR	Write Recovery Time	10	—	15	—	15	—	20	—	20	—	ns
tDS	Data Set-up Time	20	—	30	—	30	—	40	—	40	—	ns
tDH	Data Hold Time	0	—	5	—	10	—	10	—	10	—	ns
tRSC	Reset Cycle Time	50	—	65	—	80	—	100	—	140	—	ns
tRS	Reset Pulse Width ⁽³⁾	40	—	50	—	65	—	80	—	120	—	ns
tRSS	Reset Set-up Time ⁽⁴⁾	40	—	50	—	65	—	80	—	120	—	ns
tRSR	Reset Recovery Time	10	—	15	—	15	—	20	—	20	—	ns
tRTC	Retransmit Cycle Time	50	—	65	—	80	—	100	—	140	—	ns
tRT	Retransmit Pulse Width ⁽³⁾	40	—	50	—	65	—	80	—	120	—	ns
tRTS	Retransmit Set-up Time ⁽⁴⁾	40	—	50	—	65	—	80	—	120	—	ns
tRSR	Retransmit Recovery Time	10	—	15	—	15	—	20	—	20	—	ns
tEFL	Reset to EF LOW	—	50	—	65	—	80	—	100	—	140	ns
tHFH, tFFH	Reset to HF and FF HIGH	—	50	—	65	—	80	—	100	—	140	ns
tRTF	Retransmit LOW to Flags Valid	—	50	—	65	—	80	—	100	—	140	ns
tREF	Read LOW to EF Flag LOW	—	35	—	45	—	60	—	60	—	60	ns
tRFF	Read HIGH to FF HIGH	—	35	—	45	—	60	—	60	—	60	ns
tRPE	Read Pulse Width after EF HIGH	40	—	50	—	65	—	80	—	120	—	ns
tWEF	Write HIGH to EF HIGH	—	35	—	45	—	60	—	60	—	60	ns
tWFF	Write LOW to FF LOW	—	35	—	45	—	60	—	60	—	60	ns
tWHF	Write LOW to HF LOW	—	50	—	65	—	80	—	100	—	140	ns
tRHF	Read HIGH to HF HIGH	—	50	—	65	—	80	—	100	—	140	ns
tWPF	Write Pulse Width after FF HIGH	40	—	50	—	65	—	80	—	120	—	ns
tXOL	Read/Write LOW to XO LOW	—	40	—	50	—	65	—	80	—	120	ns
tXOH	Read/Write HIGH to XO HIGH	—	40	—	50	—	65	—	80	—	120	ns
tXI	XI Pulse Width ⁽³⁾	40	—	50	—	65	—	80	—	120	—	ns
tXIR	XI Recovery Time	10	—	10	—	10	—	10	—	10	—	ns
tXIS	XI Set-up Time	15	—	15	—	15	—	15	—	15	—	ns

NOTES:

1. Timings referenced as in AC Test Conditions.
2. Speed grades 65, 80, and 120ns are only available in the ceramic DIP.
3. Pulse widths less than minimum are not allowed.
4. Values guaranteed by design, not currently tested.
5. Only applies to read data flow-through mode.

26611b 06

AC TEST CONDITIONS

Input Pulse Levels	GND to 3.0V
Input Rise/Fall Times	5ns
Input Timing Reference Levels	1.5V
Output Reference Levels	1.5V
Output Load	See Figure 1

2661 tbi 07

CAPACITANCE⁽¹⁾ (T_A = +25°C, f = 1.0 MHz)

Symbol	Parameter	Condition	Max.	Unit
C _{IN} ⁽¹⁾	Input Capacitance	V _{IN} = 0V	10	pF
C _{OUT} ^(1,2)	Output Capacitance	V _{OUT} = 0V	10	pF

NOTES:

2661 tbi 08

1. This parameter is sampled and not 100% tested.
2. With output deselected.

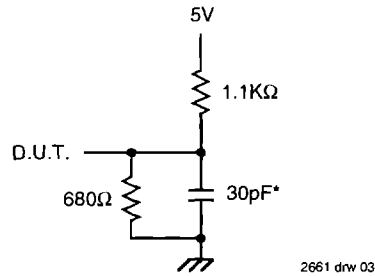

2661 drw 03

OR EQUIVALENT CIRCUIT

Figure 1. Output Load

*Includes jig and scope capacitances.

SIGNAL DESCRIPTIONS

Inputs:

DATA IN (D₀–D₈) — Data inputs for 9-bit wide data.

Controls:

RESET (\overline{RS}) — Reset is accomplished whenever the Reset (\overline{RS}) input is taken to a LOW state. During reset, both internal read and write pointers are set to the first location. A reset is required after power-up before a write operation can take place. **Both the Read Enable (\overline{R}) and Write Enable (\overline{W}) inputs must be in the HIGH state during the window shown in Figure 2 (i.e. t_{RSS} before the rising edge of \overline{RS}) and should not change until t_{RSR} after the rising edge of \overline{RS} .**

WRITE ENABLE (\overline{W}) — A write cycle is initiated on the falling edge of this input if the Full Flag (\overline{FF}) is not set. Data set-up and hold times must be adhered-to, with respect to the rising edge of the Write Enable (\overline{W}). Data is stored in the RAM array sequentially and independently of any on-going read operation.

After half of the memory is filled, and at the falling edge of the next write operation, the Half-Full Flag (\overline{HF}) will be set to LOW, and will remain set until the difference between the write pointer and read pointer is less-than or equal to one-half of the total memory of the device. The Half-Full Flag (\overline{HF}) is reset by the rising edge of the read operation.

To prevent data overflow, the Full Flag (\overline{FF}) will go LOW on the falling edge of the last write signal, which inhibits further write operations. Upon the completion of a valid read operation, the Full Flag (\overline{FF}) will go HIGH after t_{RFF} , allowing a new valid write to begin. When the FIFO is full, the internal write pointer is blocked from \overline{W} , so external changes in \overline{W} will not affect the FIFO when it is full.

READ ENABLE (\overline{R}) — A read cycle is initiated on the falling edge of the Read Enable (\overline{R}), provided the Empty Flag (\overline{EF}) is not set. The data is accessed on a First-In/First-Out basis, independent of any ongoing write operations. After Read Enable (\overline{R}) goes HIGH, the Data Outputs (Q₀ through Q₈) will return to a high-impedance condition until the next Read operation. When all the data has been read from the FIFO, the Empty Flag (\overline{EF}) will go LOW, allowing the “final” read cycle but inhibiting further read operations, with the data outputs remaining in a high-impedance state. Once a valid write operation has been accomplished, the Empty Flag (\overline{EF}) will go HIGH after t_{WEF} and a valid Read can then begin. When the FIFO is empty, the internal read pointer is blocked from \overline{R} so external changes will not affect the FIFO when it is empty.

FIRST LOAD/RETRANSMIT ($\overline{FL/RT}$) — This is a dual-purpose input. In the Depth Expansion Mode, this pin is grounded to indicate that it is the first device loaded (see Operating Modes). The Single Device Mode is initiated by grounding the Expansion In (\overline{XI}).

The IDT7203/7204/7205/7206 can be made to retransmit data when the Retransmit Enable Control (\overline{RT}) input is pulsed LOW. A retransmit operation will set the internal read pointer to the first location and will not affect the write pointer. The status of the Flags will change depending on the relative locations of the read and write pointers. Read Enable (\overline{R}) and Write Enable (\overline{W}) must be in the HIGH state during retransmit. This feature is useful when less than 2048/4096/8192/16384 writes are performed between resets. The retransmit feature is not compatible with the Depth Expansion Mode.

EXPANSION IN (\overline{XI}) — This input is a dual-purpose pin. Expansion In (\overline{XI}) is grounded to indicate an operation in the single device mode. Expansion In (\overline{XI}) is connected to Expansion Out (\overline{XO}) of the previous device in the Depth Expansion or Daisy-Chain Mode.

5

Outputs:

FULL FLAG (\overline{FF}) — The Full Flag (\overline{FF}) will go LOW, inhibiting further write operations, when the device is full. If the read pointer is not moved after Reset (\overline{RS}), the Full Flag (\overline{FF}) will go LOW after 2048/4096/8192/16384 writes.

EMPTY FLAG (\overline{EF}) — The Empty Flag (\overline{EF}) will go LOW, inhibiting further read operations, when the read pointer is equal to the write pointer, indicating that the device is empty.

EXPANSION OUT/HALF-FULL FLAG ($\overline{XO}/\overline{HF}$) — This is a dual-purpose output. In the single device mode, when Expansion In (\overline{XI}) is grounded, this output acts as an indication of a half-full memory.

After half of the memory is filled, and at the falling edge of the next write operation, the Half-Full Flag (\overline{HF}) will be set to LOW and will remain set until the difference between the write pointer

and read pointer is less than or equal to one half of the total memory of the device. The Half-Full Flag (\overline{HF}) is then reset by the rising edge of the read operation.

In the Depth Expansion Mode, Expansion In (\overline{XI}) is connected to Expansion Out (\overline{XO}) of the previous device. This output acts as a signal to the next device in the Daisy Chain by providing a pulse to the next device when the previous device reaches the last location of memory. There will be an \overline{XO} pulse when the Write pointer reaches the last location of memory, and an additional \overline{XO} pulse when the Read pointer reaches the last location of memory.

DATA OUTPUTS (Q_0-Q_8) — Q_0-Q_8 are data outputs for 9-bit wide data. These outputs are in a high-impedance condition whenever Read (\overline{R}) is in a HIGH state.

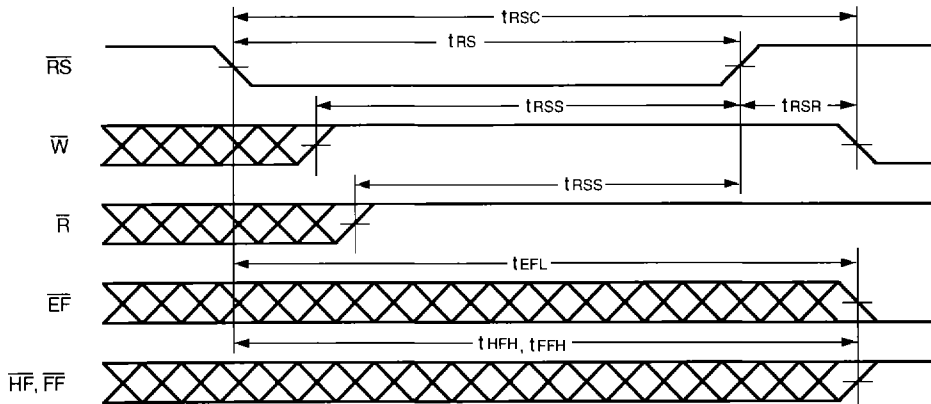

2661 drw 04

NOTE:

1. \overline{W} and \overline{R} = VIH around the rising edge of \overline{RS} .

Figure 2. Reset

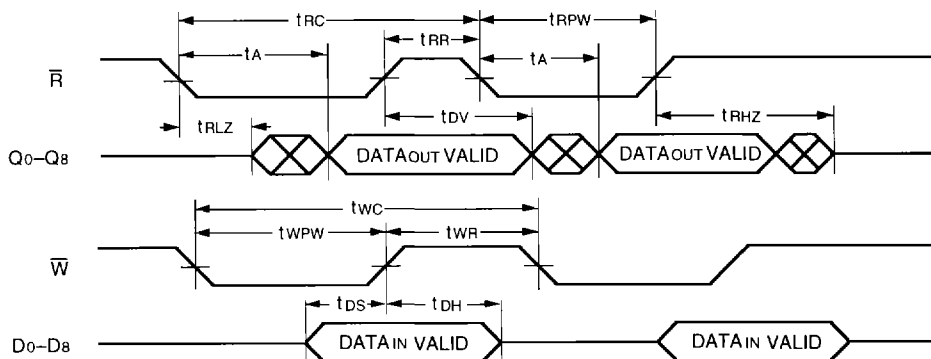

2661 drw 05

Figure 3. Asynchronous Write and Read Operation

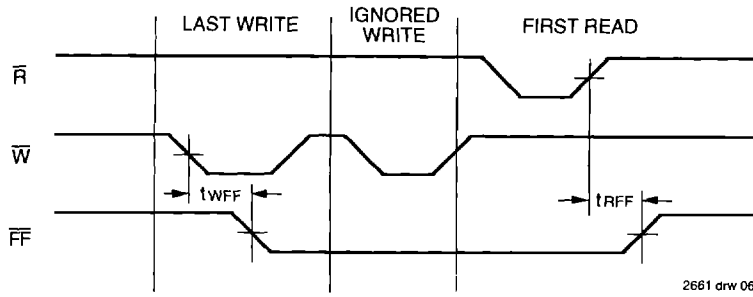

Figure 4. Full Flag Timing From Last Write to First Read

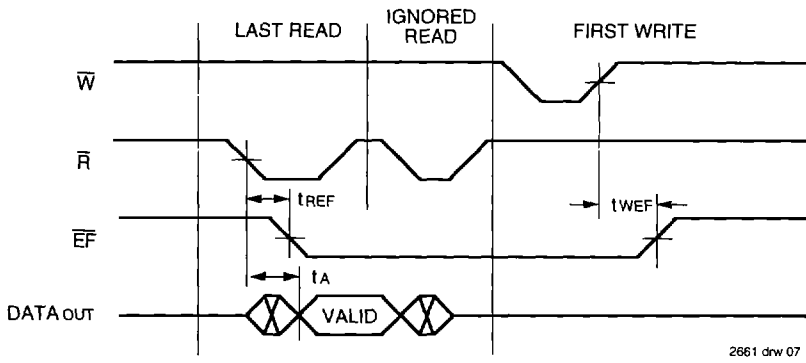
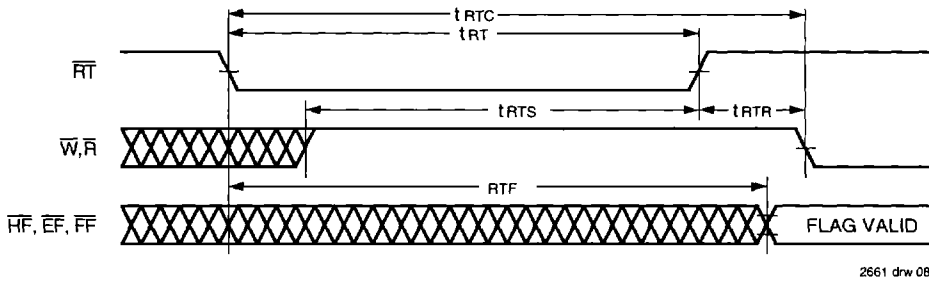

Figure 5. Empty Flag Timing From Last Read to First Write



NOTE:

1. \bar{EF} , \bar{FF} and \bar{HF} may change status during Retransmit, but flags will be valid at t_{RTC} .

Figure 6. Retransmit

5

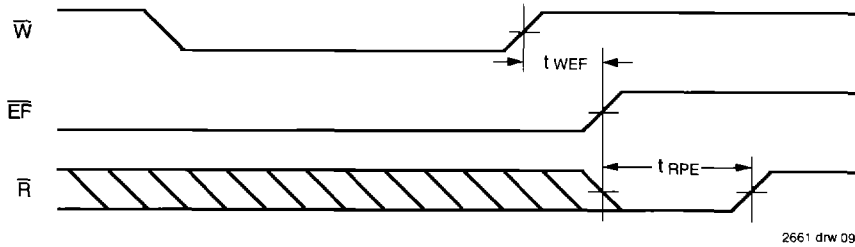

Figure 7. Minimum Timing for an Empty Flag Coincident Read Pulse.

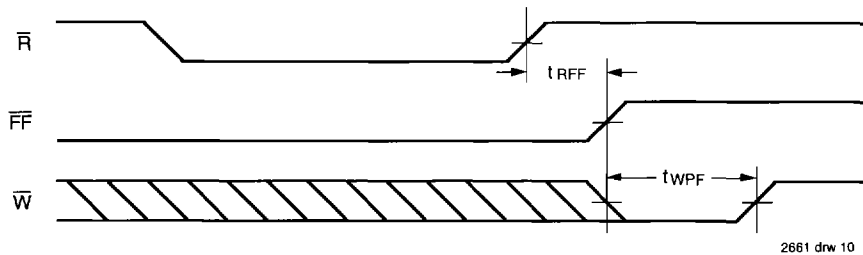

Figure 8. Minimum Timing for a Full Flag Coincident Write Pulse.

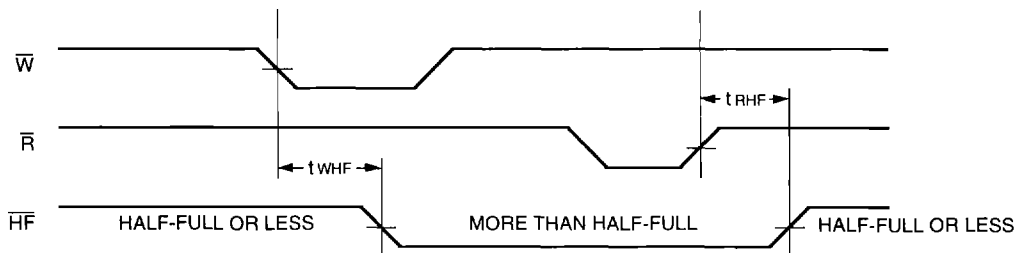

Figure 9. Half-Full Flag Timing

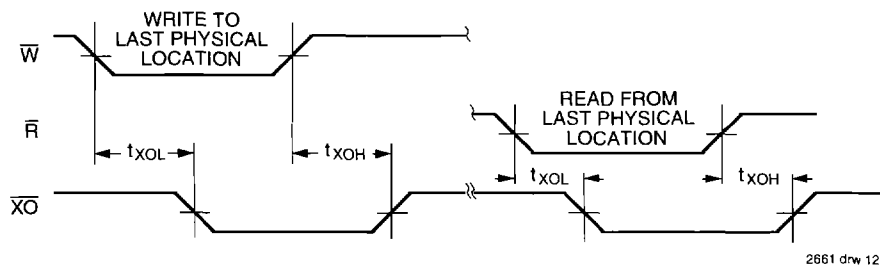

Figure 10. Expansion Out

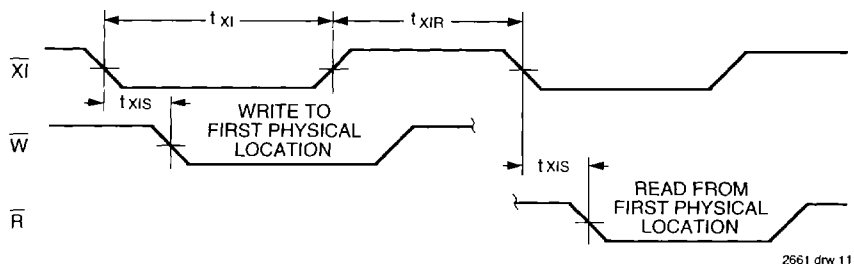

Figure 11. Expansion In

OPERATING MODES:

Care must be taken to assure that the appropriate flag is monitored by each system (i.e. \overline{FF} is monitored on the device where \overline{W} is used; \overline{EF} is monitored on the device where \overline{R} is used). For additional information, refer to Tech Note 8: *Operating FIFOs on Full and Empty Boundary Conditions* and Tech Note 6: *Designing with FIFOs*.

Single Device Mode

A single IDT7203/7204/7205/7206 may be used when the application requirements are for 2048/4096/8192/16384 words or less. The IDT7203/7204/7205/7206 is in a Single Device Configuration when the Expansion In (\overline{XI}) control input is grounded (see Figure 12).

Depth Expansion

The IDT7203/7204/7205/7206 can easily be adapted to applications when the requirements are for greater than 2048/4096/8192/16384 words. Figure 14 demonstrates Depth Expansion using three IDT7203/7204/7205/7206s. Any depth can be attained by adding additional IDT7203/7204/7205/7206s. The IDT7203/7204/7205/7206 operates in the Depth Expansion mode when the following conditions are met:

1. The first device must be designated by grounding the First Load (\overline{FL}) control input.
2. All other devices must have \overline{FL} in the HIGH state.
3. The Expansion Out (\overline{XO}) pin of each device must be tied to the Expansion In (\overline{XI}) pin of the next device. See Figure 14.
4. External logic is needed to generate a composite Full Flag (\overline{FF}) and Empty Flag (\overline{EF}). This requires the ORing of all \overline{FF} s and ORing of all \overline{EF} s (i.e. all must be set to generate the correct composite \overline{FF} or \overline{EF}). See Figure 14.
5. The Retransmit (\overline{RT}) function and Half-Full Flag (\overline{HF}) are not available in the Depth Expansion Mode.

For additional information, refer to Tech Note 9: *Cascading FIFOs or FIFO Modules*.

USAGE MODES:

Width Expansion

Word width may be increased simply by connecting the corresponding input control signals of multiple devices. Status flags (\overline{EF} , \overline{FF} and \overline{HF}) can be detected from any one device. Figure 13 demonstrates an 18-bit word width by using two IDT7203/7204/7205/7206s. Any word width can be attained by adding additional IDT7203/7204/7205/7206s (Figure 13).

Bidirectional Operation

Applications which require data buffering between two systems (each system capable of Read and Write operations) can be achieved by pairing IDT7203/7204/7205/7206s as shown in Figure 16. Both Depth Expansion and Width Expansion may be used in this mode.

Data Flow-Through

Two types of flow-through modes are permitted, a read flow-through and write flow-through mode. For the read flow-through mode (Figure 17), the FIFO permits a reading of a single word after writing one word of data into an empty FIFO. The data is enabled on the bus in ($t_{WEF} + t_A$) ns after the rising edge of \overline{W} , called the first write edge, and it remains on the bus until the \overline{R} line is raised from LOW-to-HIGH, after which the bus would go into a three-state mode after t_{RHZ} ns. The \overline{EF} line would have a pulse showing temporary deassertion and then would be asserted.

In the write flow-through mode (Figure 18), the FIFO permits the writing of a single word of data immediately after reading one word of data from a full FIFO. The \overline{R} line causes the \overline{FF} to be deasserted but the \overline{W} line being LOW causes it to be asserted again in anticipation of a new data word. On the rising edge of \overline{W} , the new word is loaded in the FIFO. The \overline{W} line must be toggled when \overline{FF} is not asserted to write new data in the FIFO and to increment the write pointer.

Compound Expansion

The two expansion techniques described above can be applied together in a straightforward manner to achieve large FIFO arrays (see Figure 15).

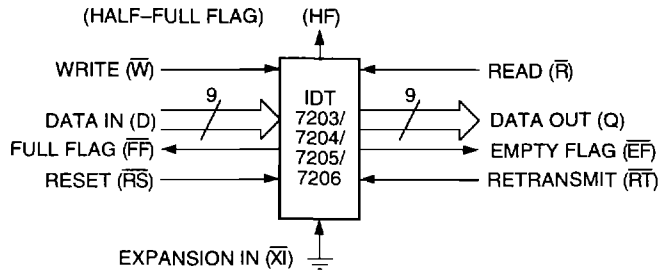

2661 drw 14

Figure 12. Block Diagram of 2048 x 9/4096 x 9/8192 x 9/16384 x 9 FIFO Used in Single Device Mode

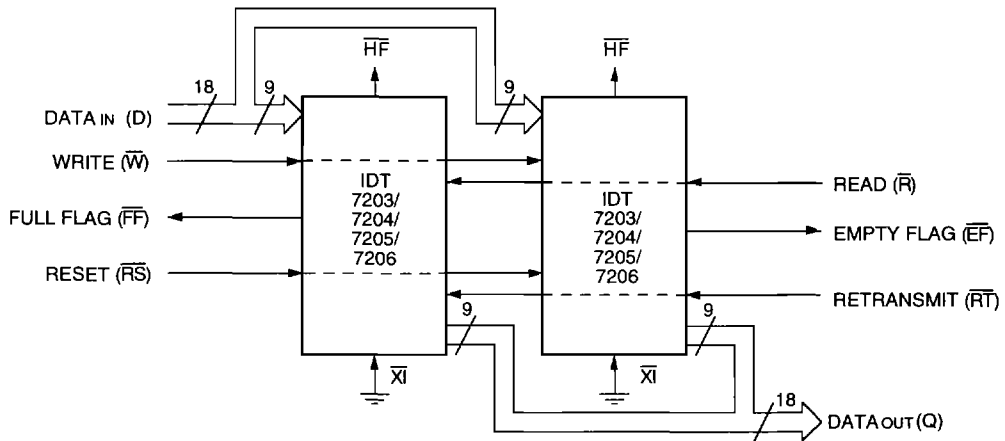

2661 drw 15

NOTE:

1. Flag detection is accomplished by monitoring the \overline{FF} , \overline{EF} and \overline{HF} signals on either (any) device used in the width expansion configuration. Do not connect any output signals together.

Figure 13. Block Diagram of 2048 x 18/4096 x 18/8192 x 18/16384 x 18 FIFO Memory Used in Width Expansion Mode

TRUTH TABLES

TABLE I – RESET AND RETRANSMIT

SINGLE DEVICE CONFIGURATION/WIDTH EXPANSION MODE

Mode	Inputs			Internal Status		Outputs		
	\overline{RS}	\overline{RT}	\overline{XI}	Read Pointer	Write Pointer	\overline{EF}	\overline{FF}	\overline{HF}
Reset	0	X	0	Location Zero	Location Zero	0	1	1
Retransmit	1	0	0	Location Zero	Unchanged	X	X	X
Read/Write	1	1	0	Increment ⁽¹⁾	Increment ⁽¹⁾	X	X	X

NOTE:

1. Pointer will Increment if flag is HIGH.

2661 tbl 09

TABLE II – RESET AND FIRST LOAD

DEPTH EXPANSION/COMPOUND EXPANSION MODE

Mode	Inputs			Internal Status		Outputs	
	\overline{RS}	\overline{FL}	\overline{XI}	Read Pointer	Write Pointer	\overline{EF}	\overline{FF}
Reset First Device	0	0	(1)	Location Zero	Location Zero	0	1
Reset all Other Devices	0	1	(1)	Location Zero	Location Zero	0	1
Read/Write	1	X	(1)	X	X	X	X

NOTES:

1. \overline{XI} is connected to \overline{XO} of previous device. See Figure 14.

2. \overline{RS} = Reset Input, $\overline{FL}/\overline{RT}$ = First Load/Retransmit, \overline{EF} = Empty Flag Output, \overline{FF} = Full Flag Output, \overline{XI} = Expansion Input, \overline{HF} = Half-Full Flag Output

2661 tbl 10

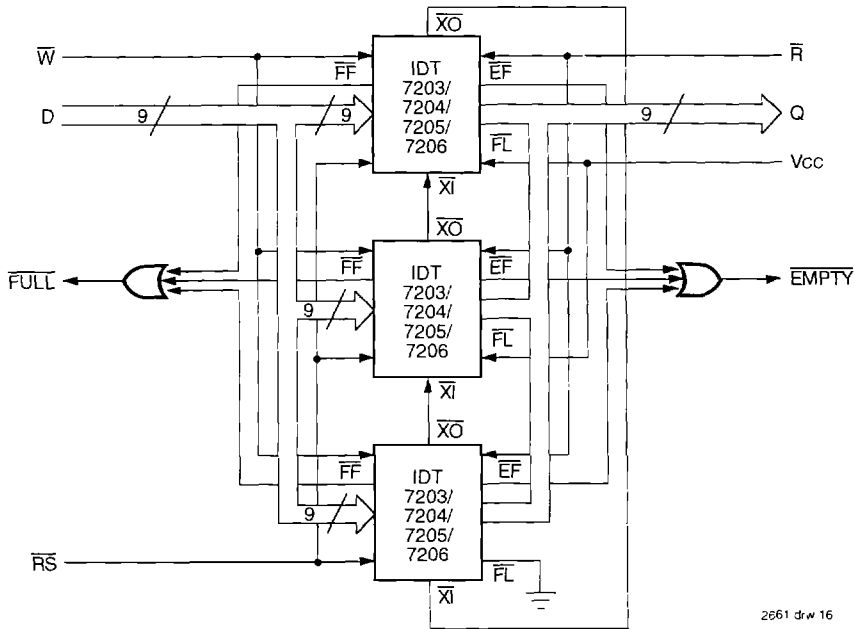
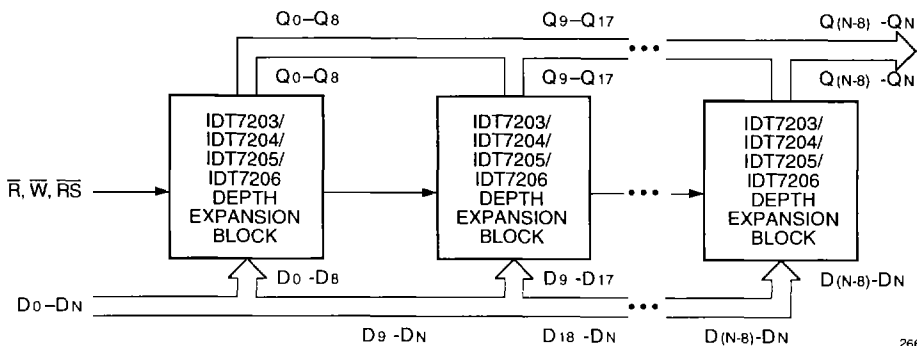

Figure 14. Block Diagram of 6149 x 9/12298 x 9/24596 x 9/49152 x 9 FIFO Memory (Depth Expansion)



2661 drw 17

NOTES:

1. For depth expansion block see section on Depth Expansion and Figure 14.
2. For Flag detection see section on Width Expansion and Figure 13.

Figure 15. Compound FIFO Expansion

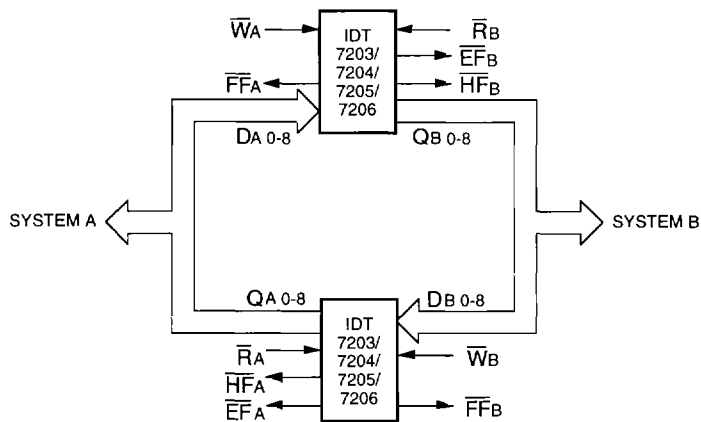

2661 drw 18

Figure 16. Bidirectional FIFO Operation

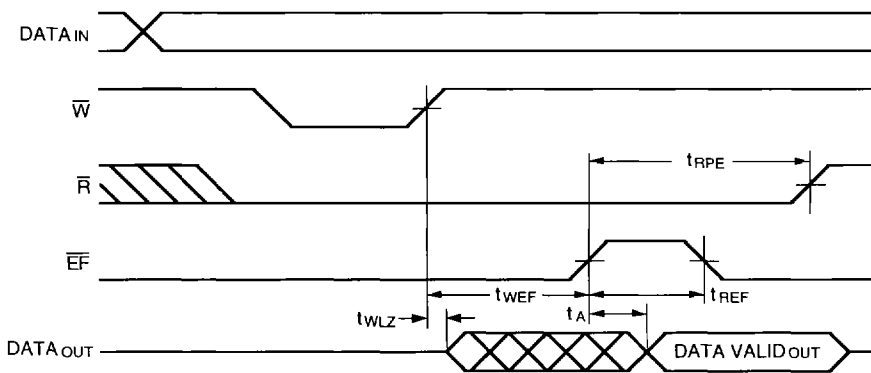

2661 drw 19

Figure 17. Read Data Flow-Through Mode

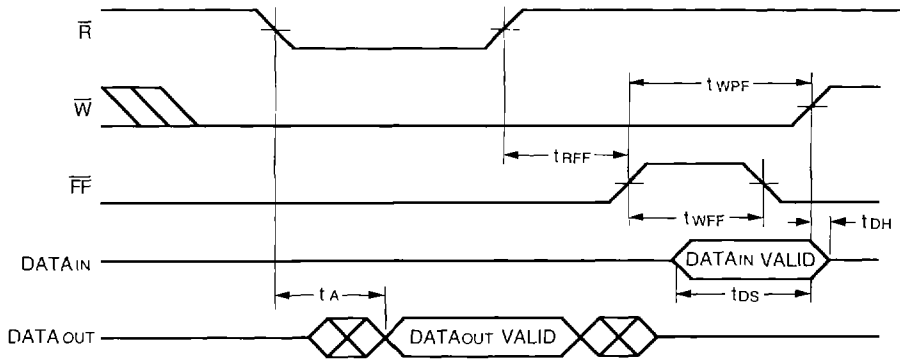

2661 drw 20

Figure 18. Write Data Flow-Through Mode

ORDERING INFORMATION

IDT	XXXX Device Type	X Power	XX Speed	X Package	X Process/ Temperature Range		
					Blank	Commercial (0°C to +70°C)	
					B	Military (-55°C to +125°C) Compliant to MIL-STD-883, Class B	
					P	Plastic DIP	
					TP	Plastic THINDIP (all except 7206)	
					D	Ceramic DIP	
					TD	Ceramic THINDIP (all except 7206)	
					J	Plastic Leaded Chip Carrier	
					L	Leadless Chip Carrier (Military only)	
					SO	Small Outline IC (7204 only)	
					1C	Commercial 7203/04 Only	
					1F	Commercial Only	
					2C	} Access Time (t_A) Speed in ns	
					25		Commercial Only
					3C		Military Only
					35		Commercial Only
					4C		Military 7203/04 Only
					5C	} Military 7203/04DB Only	
					65		
					8C		
					12C		
					S	Standard Power (7203/7204 only)	
					L	Low Power	
					7203	2048 x 9 FIFO	
					7204	4096 x 9 FIFO	
					7205	8192 x 9 FIFO	
					7206	16384 x 9 FIFO	

2661 drw 21

