

8-bit Proprietary Microcontrollers

CMOS

F²MC-8L MB89580B/580BW Series

MB89583B/585B/589B/P585B/P589B/ MB89583BW/585BW/P585BW

■ DESCRIPTION

The MB89580B/BW series is a line of general-purpose, single-chip microcontrollers. In addition to a compact instruction set, these microcontrollers contain a variety of peripheral functions, such as PLL clock control, timers, a serial interface, a PWM timer, and the USB function. In particular, these microcontrollers contain one USB function channel to support both full and low speeds.

■ FEATURES

- **Package type**
64-pin LQFP package (0.5 mm and 0.65 mm pitch)
- **High-speed operations at low voltage**
Minimum execution time : 0.33 μ s (Automatically generates a 12 MHz main clock and a 48 MHz USB interface synchronization clock with an externally supplied 6 MHz clock and the internal PLL circuit.)
- **F²MC-8L CPU core**
Instruction set that is optimum to the controllers
 - Multiplication and division instructions
 - 16-bit arithmetic operations
 - branch instructions by bit testing
 - bit manipulation instructions, etc.

(Continued)

■ PACKAGES

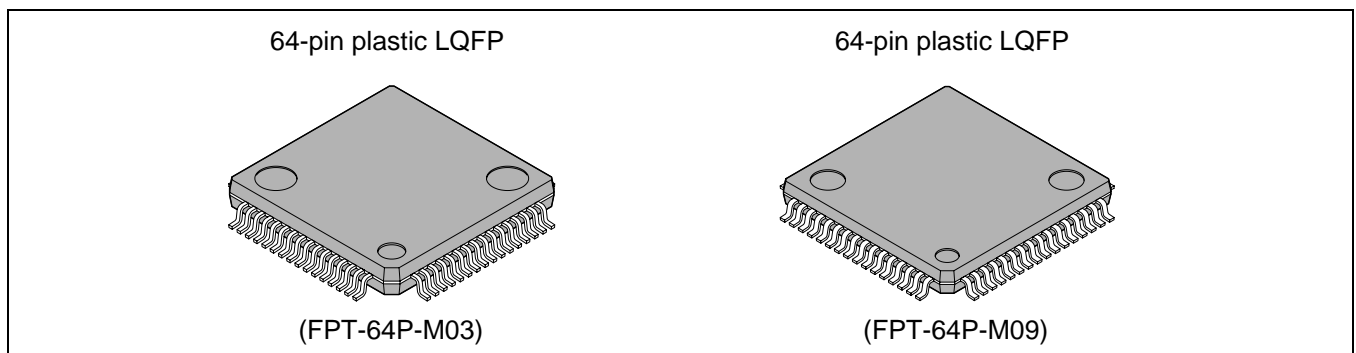

MB89580B/580BW series

(Continued)

- **PLL clock control**

The internal PLL clock circuit allows the use of low-speed clocks which are advantageous to noise characteristics.

(6 MHz externally-supplied clock→12 MHz internal system clock)

- **Various timers**

8-bit PWM timer (can be used as either 8-bit PWM timer × 2 channels or PPG timer × 1 channel)

Internal 21-bit timebase timer

- **Internal USB transceiver circuit (Compatible with full and low speeds)**

- **USB function**

Compliant to USB Protocol Revision 1.0

Support for both low and full speeds (selectable)

Allows four endpoints to be specified at maximum.

Types of transfer supported : control/interrupt/bulk/isochronous

Built-in DMAC (Maps the buffer for each endpoint on to the internal RAM to directly access the memory for function's send and receive data.)

- **UART/serial interface**

Built-in UART/SIO function (selectable by switching)

- **External interrupt**

External interrupt (level detection × 8 channels)

Eight inputs are independent of one another and can also be used for resetting from low-power consumption mode (the L-level detection feature available) .

- **Low power consumption (standby mode supported)**

Stop mode (There is almost no current consumption since oscillation stops.)

Sleep mode (This mode stops the running CPU.)

- **A maximum of 53 general-purpose I/O ports**

General-purpose I/O ports (CMOS) : 34

General-purpose output ports (CMOS) : 8

General-purpose I/O ports (Nch open drain) : 3

General-purpose input ports (CMOS 3.3 V input-compatible) : 8

- **Parallel ports**

Also serve as eight of the general-purpose I/O ports (CMOS)

Interrupt function available

Allows asynchronous read and write by external signals

- **Power supply**

Supply voltage : 3.0 V to 5.5 V

MB89580B/580BW series

■ PRODUCT LINEUP

Part number		MB89583B	MB89585B	MB89P585B	MB89589B	MB89P589B	MB89583BW	MB89585BW	MB89P585BW	
Parameter										
ROM size		8 KB	16 KB				8 KB	16 KB		
RAM size		512 B	1 KB		18 KB		512 B	1 KB		
Package		LQFP-64 (FPT-64P-M03)			LQFP-64 (FPT-64P-M09)		LQFP-64 (FPT-64P-M03)			
Operation at USB reset		High impedance state					Low-level output			
Others		MASK product		OTP/EVA product	MASK product	OTP/EVA product	MASK product		OTP/EVA product	
CPU functions		Number of instructions : 136 Instruction bit length : 8 bits Instruction length : 1 to 3 bytes Data bit length : 1, 8, and 16 bits Minimum execution time : 0.33 μs (6 MHz) Interrupt processing time : 3 μs (6 MHz)								
Peripheral functions	General-purpose ports	General-purpose I/O ports (34 : CMOS, 3 : Nch open drain) General-purpose output ports (8 : CMOS) General-purpose input ports (8 : CMOS 3.3 V input)								
	Parallel ports	Shares eight (P40 through P47) of the above general-purpose I/O ports. Allows asynchronous read and write by external signals. An interrupt function is available to set data.								
	USB function	Can be set to full/low speed. Four endpoints at maximum Power supply mode : Can be set to own power supply/bus power supply mode. FIFO 8 bits × 8 built in Built-in DMAC (Can be set to DMA transfer to the internal RAM or to the external FIFO.)								
	PWM timer	8-bit PWM timer operation × 2 channels (can also be used as a PPG × 1 channel timer)								
	UART	SIO	Allows switching between UART (clock-synchronous/asynchronous data transfer allowed) and SIO (simple serial transfer) .							
	Timebase timer	21-bit timebase timer								
	Clock output	Allows output of two main clock divisions								
Standby mode		Sleep mode and Stop mode								

■ PACKAGES AND CORRESPONDING PRODUCTS

Package	MB89583B	MB89585B	MB89P585B	MB89589B	MB89P589B	MB89583BW	MB89585BW	MB89P585BW
FPT-64P-M03	○	○	○	×	×	○	○	○
FPT-64P-M09	×	×	×	○	○	×	×	×

○ : Available × : Not available

MB89580B/580BW series

■ DIFFERENCES AMONG PRODUCTS

1. Memory Size

Before evaluating using the OTP product, verify its differences from the product that will actually be used.

2. Current Consumption

When operated at low speeds, a product mounted with either one-time PROM or EPROM consumes more current than a product mounted with a mask ROM. However, in sleep/stop mode the current consumption is the same.

For detailed information on each package, see “■ PACKAGE DIMENSIONS.”

3. Differences Between the MB89580B series and the MB89580BW Series

MB89580B series : Remains in high impedance state until USB connection takes place. Before the USB connection, use one general-purpose port output to control pullup resistance connection of this port by software.

MB89580BW : Outputs at low level until USB connection takes place.

• Example MB89580B product connection

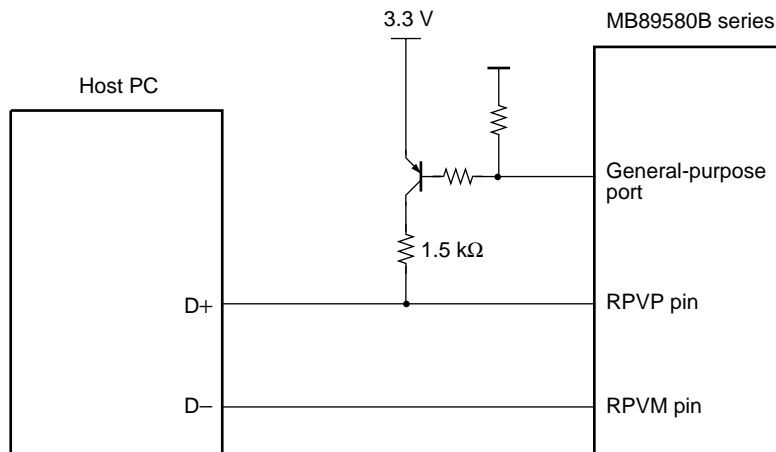

• Example MB89580BW product connection

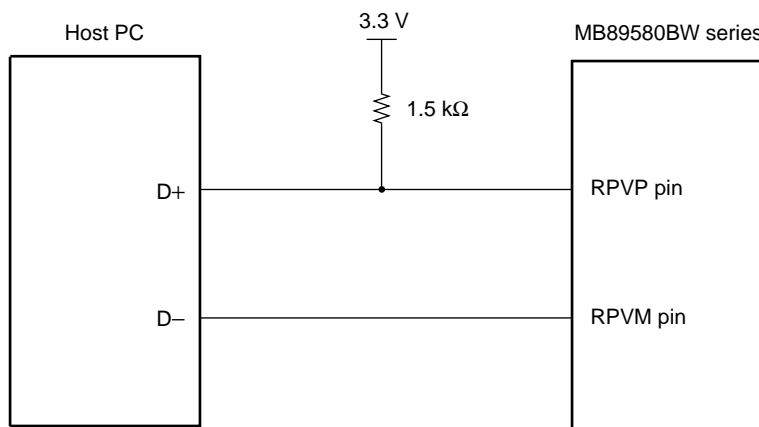

Note : Full speed is assumed in the above examples.

MB89580B/580BW series

■ PIN ASSIGNMENT

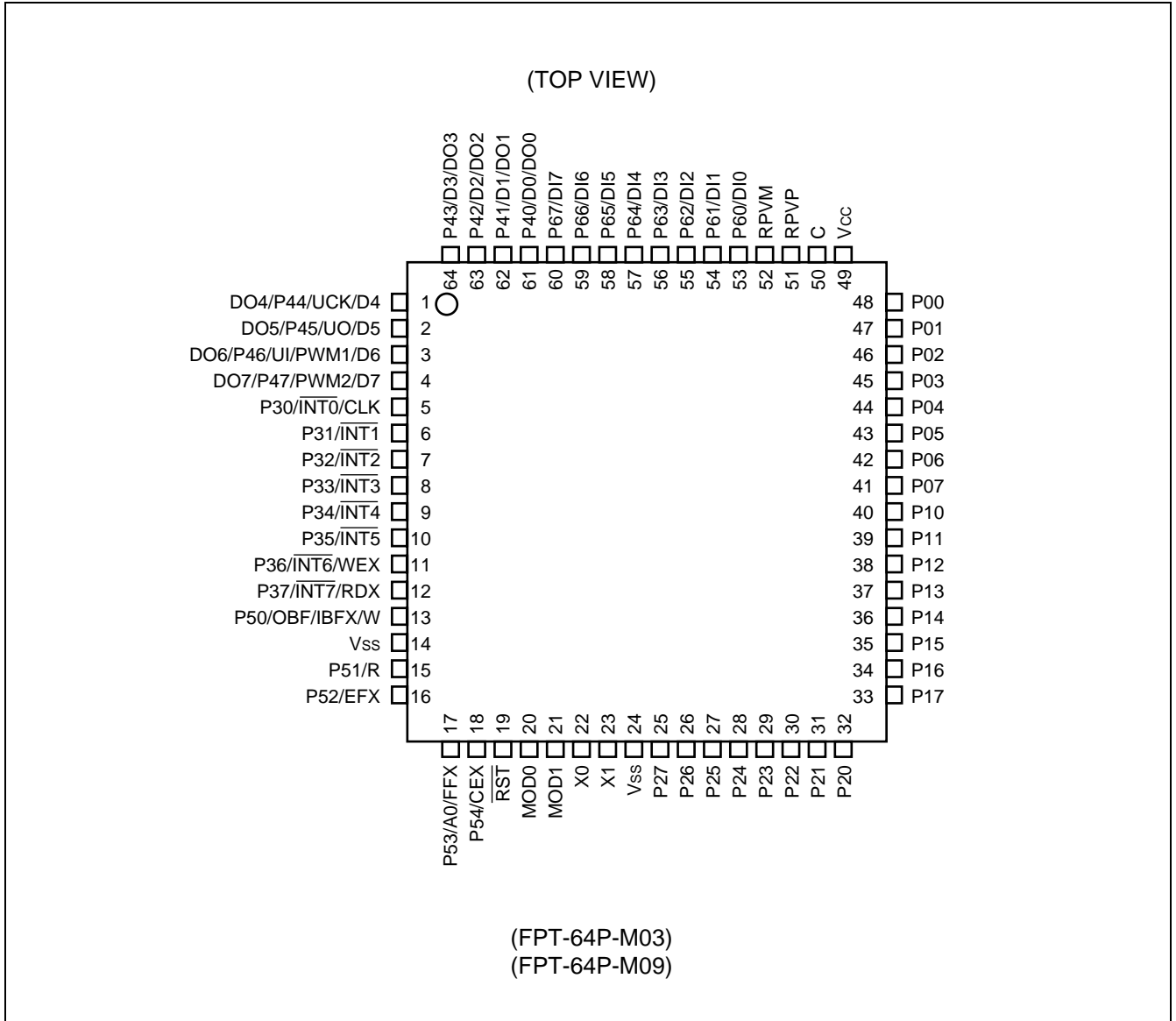

MB89580B/580BW series

■ PIN DESCRIPTION

Pin No.	Pin name	Circuit type	Function
1	P44/U \overline{C} K/D4/ DO4	E	General-purpose CMOS I/O pin UART/S10 clock I/O This pin also serves as a parallel interface/external FIFO data output pin.
2	P45/UO/D5/ DO5	B	General-purpose CMOS I/O pin UART/S10 serial data output This pin also serves as a parallel interface/external FIFO data output pin.
3	P46/UI/ PWM1/D6/ DO6	E	General-purpose CMOS I/O pin UART/S10 serial data input PWM timer This pin also serves as a parallel interface/external FIFO data output pin.
4	P47/PWM2/ D7/DO7	B	General-purpose CMOS I/O pin PWM timer This pin also serves as a parallel interface/external FIFO data output pin.
5	P30/ $\overline{INT0}$ / CLK	E	General-purpose CMOS I/O pin Clock output pin This pin also serves as an external interrupt input pin. The external interrupt input is a hysteresis input. (Level detection)
6	P31/ $\overline{INT1}$	E	General-purpose CMOS I/O pin This pin also serves as an external interrupt input pin. The external interrupt input is a hysteresis input. (Level detection)
7	P32/ $\overline{INT2}$	E	General-purpose CMOS I/O pin This pin also serves as an external interrupt input pin. The external interrupt input is a hysteresis input. (Level detection)
8	P33/ $\overline{INT3}$	E	General-purpose CMOS I/O pin This pin also serves as an external interrupt input pin. The external interrupt input is a hysteresis input. (Level detection)
9	P34/ $\overline{INT4}$	E	General-purpose CMOS I/O pin This pin also serves as an external interrupt input pin. The external interrupt input is a hysteresis input. (Level detection)
10	P35/ $\overline{INT5}$	E	General-purpose CMOS I/O pin This pin also serves as an external interrupt input pin. The external interrupt input is a hysteresis input. (Level detection)
11	P36/ $\overline{INT6}$ / WEX	E	General-purpose CMOS I/O pin This pin also serves as an external interrupt input pin. The external interrupt input is a hysteresis input. (Level detection) This pin also serves as the parallel interface write strobe input pin.
12	P37/ $\overline{INT7}$ / RDX	E	General-purpose CMOS I/O pin This pin also serves as an external interrupt input pin. The external interrupt input is a hysteresis input. (Level detection) This pin also serves as the parallel interface read strobe input pin.
13	P50/OBF/ IBFX/W	B	General-purpose CMOS I/O pin Interrupt output to the parallel interface host. This pin also serves the OUT FIFO data strobe pin.

(Continued)

MB89580B/580BW series

Pin No.	Pin name	Circuit type	Function
14	V _{SS}	—	Power supply pin (GND)
15	P51/R	B	General-purpose CMOS I/O pin. This pin also serves the IN FIFO data strobe pin.
16	P52/EFX	K	General-purpose Nch open drain I/O pin. This pin also serves as the IN FIFO data enable input pin.
17	P53/A0/FFX	K	General-purpose Nch open drain I/O pin. Parallel interface's data select input This pin also serves as the OUT FIFO data enable input pin.
18	P54/CEX	K	General-purpose Nch open drain I/O pin. This pin also serves as the parallel interface device select input pin.
19	$\overline{\text{RST}}$	I	Reset pin. (Reset on the negative logic low level.)
20	MOD0	F	An operating mode designation pin. Connect directly to V _{SS} .
21	MOD1	F	An operating mode designation pin. Connect directly to V _{SS} .
22	X0	A	Pins for the connection of crystal oscillatoion circuit (6 MHz)
23	X1		
24	V _{SS}	—	Power supply pin (GND)
25	P27	B	General-purpose CMOS output pin
26	P26	B	General-purpose CMOS output pin
27	P25	B	General-purpose CMOS output pin
28	P24	B	General-purpose CMOS output pin
29	P23	B	General-purpose CMOS output pin
30	P22	B	General-purpose CMOS output pin
31	P21	B	General-purpose CMOS output pin
32	P20	B	General-purpose CMOS output pin
33	P17	B	General-purpose CMOS I/O pin
34	P16	B	General-purpose CMOS I/O pin
35	P15	B	General-purpose CMOS I/O pin
36	P14	B	General-purpose CMOS I/O pin
37	P13	B	General-purpose CMOS I/O pin
38	P12	B	General-purpose CMOS I/O pin
39	P11	B	General-purpose CMOS I/O pin
40	P10	B	General-purpose CMOS I/O pin
41	P07	B	General-purpose CMOS I/O pin
42	P06	B	General-purpose CMOS I/O pin
43	P05	B	General-purpose CMOS I/O pin
44	P04	B	General-purpose CMOS I/O pin

(Continued)

MB89580B/580BW series

(Continued)

Pin No.	Pin name	Circuit type	Function
45	P03	B	General-purpose CMOS I/O pin
46	P02	B	General-purpose CMOS I/O pin
47	P01	B	General-purpose CMOS I/O pin
48	P00	B	General-purpose CMOS I/O pin
49	V _{cc}	—	Power supply pin
50	C	—	Connect an external capacitor of 0.1 μ F. When using with 3.3 V power supply, connect this pin with the V _{cc} pin to set to 3.3 V input.
51	RPVP	USBDRV	USB route port + pin
52	RPVM	USBDRV	USB router port – pin
53	P60/DI0	F	General-purpose CMOS input pin (3.3 V input) This pin also serves as an external FIFO data input pin. (LSB)
54	P61/DI1	F	General-purpose CMOS input pin (3.3 V input) This pin also serves as an external FIFO data input pin.
55	P62/DI2	F	General-purpose CMOS input pin (3.3 V input) This pin also serves as an external FIFO data input pin.
56	P63/DI3	F	General-purpose CMOS input pin (3.3 V input) This pin also serves as an external FIFO data input pin.
57	P64/DI4	F	General-purpose CMOS input pin (3.3 V input) This pin also serves as an external FIFO data input pin.
58	P65/DI5	F	General-purpose CMOS input pin (3.3 V input) This pin also serves as an external FIFO data input pin.
59	P66/DI6	F	General-purpose CMOS input pin (3.3 V input) This pin also serves as an external FIFO data input pin.
60	P67/DI7	F	General-purpose CMOS input pin (3.3 V input) This pin also serves as an external FIFO data input pin. (MSB)
61	P40/D0/DO0	B	General-purpose CMOS I/O pin This pin serves as a parallel interface/external FIFO data output pin.
62	P41/D1/DO1	B	General-purpose CMOS I/O pin This pin serves as a parallel interface/external FIFO data output pin.
63	P42/D2/DO2	B	General-purpose CMOS I/O pin This pin serves as a parallel interface/external FIFO data output pin.
64	P43/D3/DO3	B	General-purpose CMOS I/O pin This pin serves as a parallel interface/external FIFO data output pin.

MB89580B/580BW series

■ I/O CIRCUIT TYPE

Type	Circuit	Remarks
A	<p>Standby control signal</p>	<ul style="list-style-type: none"> Oscillation feedback resistance : 1 MΩ approx.
B	<p>Pullup control register</p> <p>Standby control signal</p> <p>Input</p>	<ul style="list-style-type: none"> CMOS I/O
E	<p>Pullup control register</p> <p>Standby control signal</p> <p>Port input</p> <p>Resource input</p>	<ul style="list-style-type: none"> CMOS I/O Hysteresis input
F	<p>Input</p>	<ul style="list-style-type: none"> CMOS input
I	<p>Input</p>	<ul style="list-style-type: none"> Hysteresis I/O Pullup resistance

(Continued)

MB89580B/580BW series

(Continued)

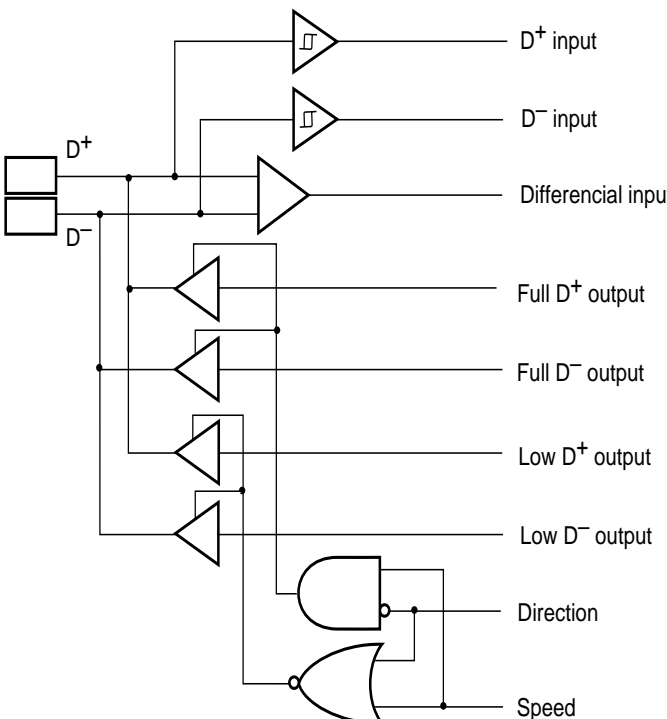
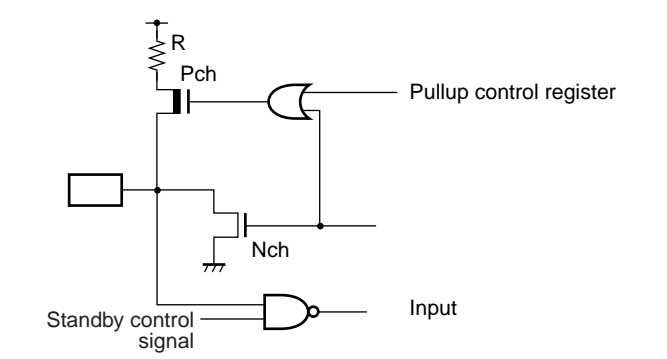
Type	Circuit	Remarks
USBDRV	 <p>The diagram shows the internal logic for the USBDRV type. It features two input pins, D+ and D-. The D+ input is connected to a buffer and a differential input stage. The D- input is connected to a buffer, a differential input stage, and four output drivers. The output drivers are labeled: Full D+ output, Full D- output, Low D+ output, and Low D- output. The direction of data flow is controlled by a 'Direction' signal, which is the output of an AND gate with inputs from the D+ and D- buffers. The 'Speed' signal is the output of an OR gate with inputs from the D+ and D- buffers.</p>	<ul style="list-style-type: none"> • USB I/O
K	 <p>The diagram shows the internal logic for type K. It features an input pin connected to a pullup resistor (R) and a pullup control register (Pch). The pullup control register is the output of an AND gate with inputs from the input pin and a standby control signal. The input pin is also connected to an N-channel MOSFET (Nch) which is grounded. The standby control signal is the output of an AND gate with inputs from the input pin and the pullup control register.</p>	<ul style="list-style-type: none"> • Nch open drain I/O

■ HANDLING DEVICES

1. Preventing Latchup

Latchup may occur on CMOS ICs if voltage higher than V_{cc} or lower than V_{ss} is applied to input or output pins other than the medium- and high-voltage pins or if voltage higher than the rating is applied between V_{cc} and V_{ss} .

When latchup occurs, power supply current increases rapidly and might thermally damage elements. When using, take great care not to exceed the absolute maximum ratings.

Also take care to prevent the analog input from exceeding the digital power supply (V_{cc}) when the power supply to the analog power system is turned on and off.

2. Treatment of Unused Input Pins

Leaving unused input pins open could cause malfunctions and latchup leading to permanent damage to the pins. These unused pins should be connected to a pullup or pulldown resistance of at least $2\text{ k}\Omega$ between the pin and the power supply.

Unused I/O pins should be placed in output state to leave it open or pins that are in input state should be handled the same as unused input pins.

3. Power Supply Voltage Fluctuations

Although V_{cc} power supply voltage is assured to operate within the rated range, a rapid fluctuation of the voltage could cause malfunctions even if it occurs within the rated range. Stabilizing voltage supplied to the IC is therefore important. As stabilization guidelines, it is recommended to control power so that V_{cc} ripple fluctuations (P-P value) will be less than 10% of the standard V_{cc} value at the commercial frequency (50 to 60 Hz) and the transient fluctuation rate will be less than 0.1 V/ms at the time of a momentary fluctuation such as when power is switched.

MB89580B/580BW series

■ ONE-TIME PROM AND EPROM MICROCONTROLLER PROGRAMMING SPECIFICATIONS

PROM mode is available on the MB89P585B/BW microcontrollers. The use of a dedicated adapter allows you to program the devices with a general-purpose ROM programmer. However, keep in mind that electronic signature mode is not available.

1. ROM programmer adapter and its compatible programmers

Package	Compatible adapter	Compatible programmers and models
	Sun Hayato Co, Ltd.	Ando Denki K. K.
FTP-64P-M03	ROM2-64LQF-32DP-8LA	AF9708 (Version 1.40 or higher) AF9709 (Version 1.40 or higher)
FTP-64P-M09	ROM2-64QF2-32DP-8LA2	AF9723 (Version 1.50 or higher)

Inquiry:

Sun Hayato Co., Ltd. : TEL. 81-3-3986-0403
 Ando Denki K. K. : TEL. 81-3-3733-1160

2. Memory map in PROM mode

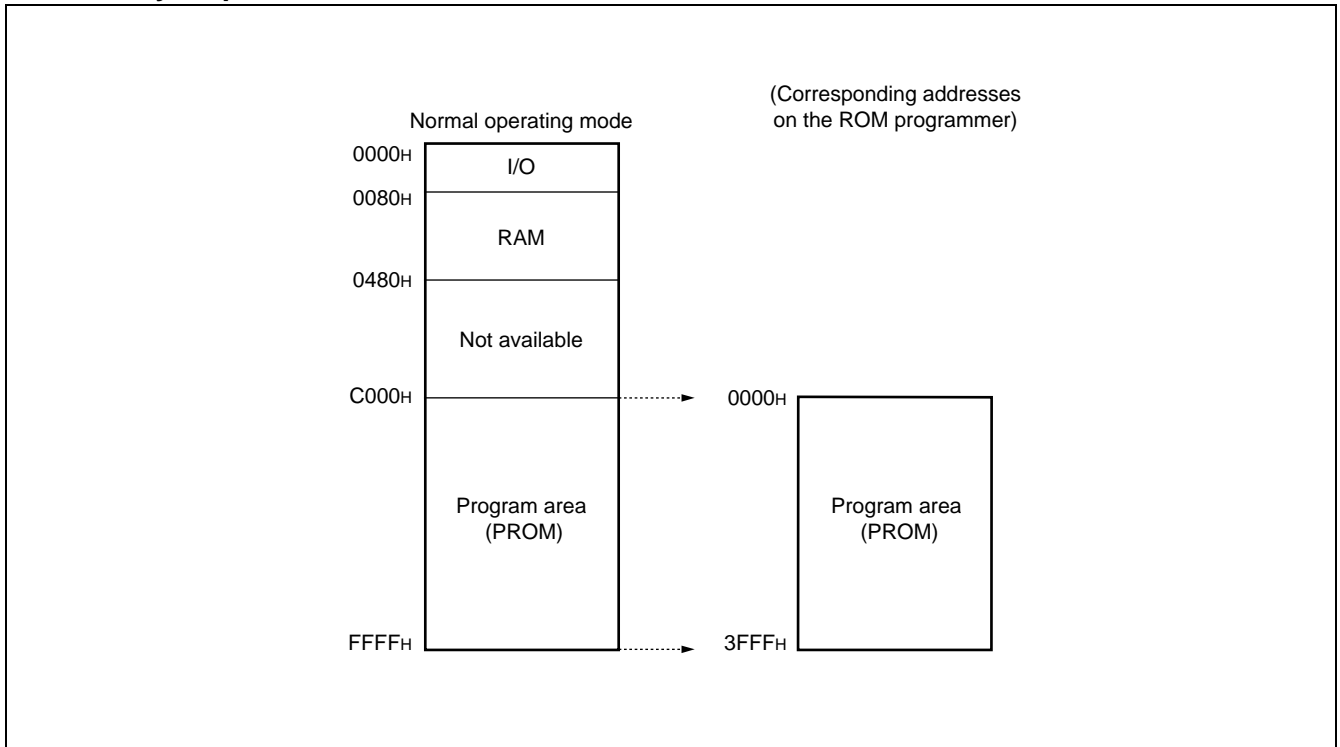

3. Programming the EPROM (Using the Ando Denki K.K. programmer)

- (1) Set the EPROM programmer type code to 17209.
- (2) Load program data on to the EPROM programmer at 0000_H to 3FFF_H.
- (3) Program C000_H to FFFF_H with the EPROM programmer.

MB89580B/580BW series

■ BLOCK DIAGRAM

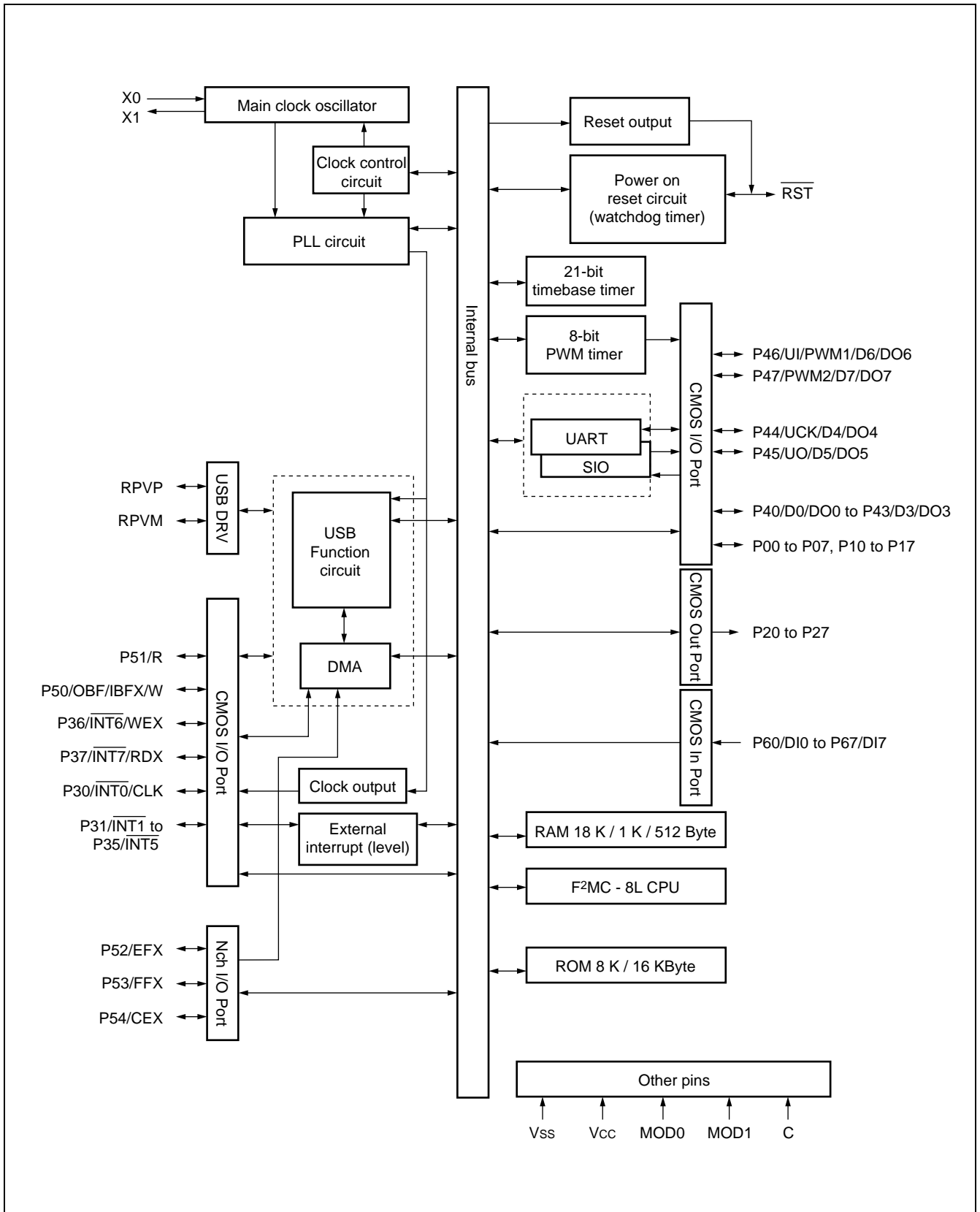

MB89580B/580BW series

■ CPU CORE

1. Memory Space

The MB89580B/BW microcontrollers offer a memory space of 64 Kbytes consisting of the I/O, RAM and ROM areas. The memory space contains areas that are used for specific purposes, such as a general-purpose register and a vector table.

- I/O area (addresses : 0000_H through 007F_H)

This area is assigned with the control and data registers, for example, of peripheral functions to be built in. The I/O area is as accessible as the memory since the area is assigned to a part of the memory space. Direct addressing also allows the area to be accessed faster.

- RAM area

As an internal data area, a static RAM is built in.

The internal RAM capacity varies with the product type.

The area 80_H to FF_H can be accessed at high speed with direct addressing.

The area 100_H to 1FF_H can be used a general-purpose register area. (The usable area is limited depending on the product.)

When reset, RAM data becomes undefined.

- ROM area

As an internal program area, a ROM is built in.

The internal ROM capacity varies with the product type.

The area FFC0_H to FFFF_H should be used for a vector table, for example.

- Memory map

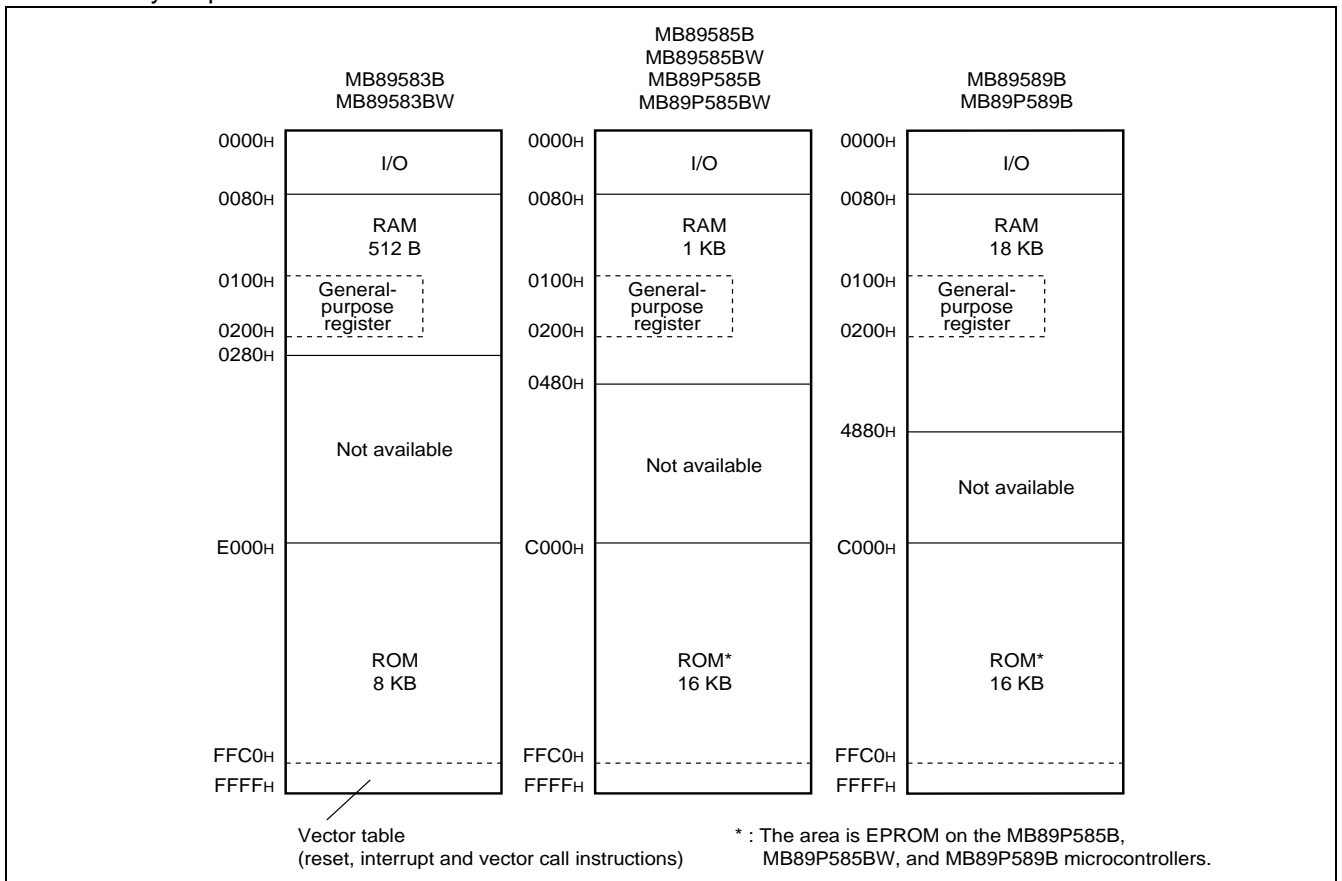

MB89580B/580BW series

2. Registers

The MB89580B/BW series has two types of registers; the registers dedicated to specific purposes in the CPU and the general-purpose registers.

The dedicated registers are as follows:

- Program counter (PC) : A 16-bit register to indicate locations where instructions are stored.
- Accumulator (A) : A 16-bit register for temporary storage of operations. In the case of an 8-bit data processing instruction, the lower one byte is used.
- Temporary accumulator (T) : A 16-bit register which performs operations with the accumulator. In the case of an 8-bit data processing instruction, the lower one byte is used.
- Index register (IX) : A 16-bit register for index modification.
- Extra pointer (EP) : A 16-bit register to point to a memory address.
- Stack pointer (SP) : A 16-bit register to indicate a stack area.
- Program status (PS) : A 16-bit register to store a register pointer or a condition code.

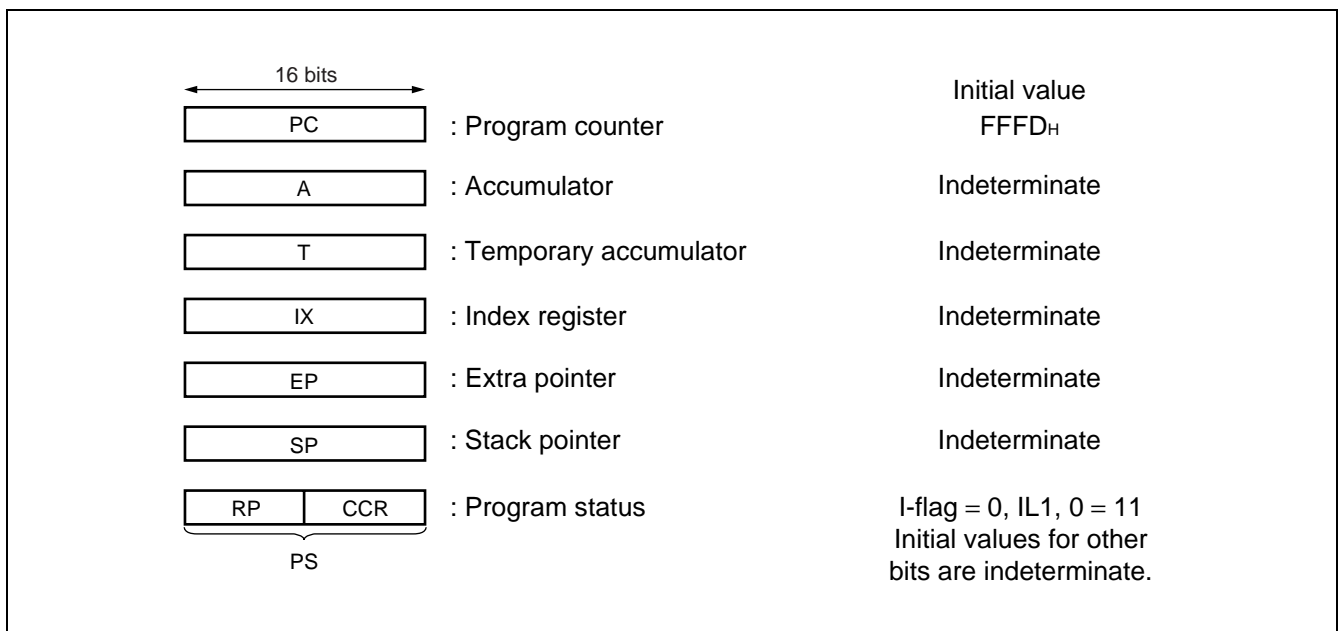

MB89580B/580BW series

The PS register can further be divided into the register bank pointer in the higher 8 bits (RP) and the condition code register in the lower 8 bits (CCR) . (See the diagram below.)

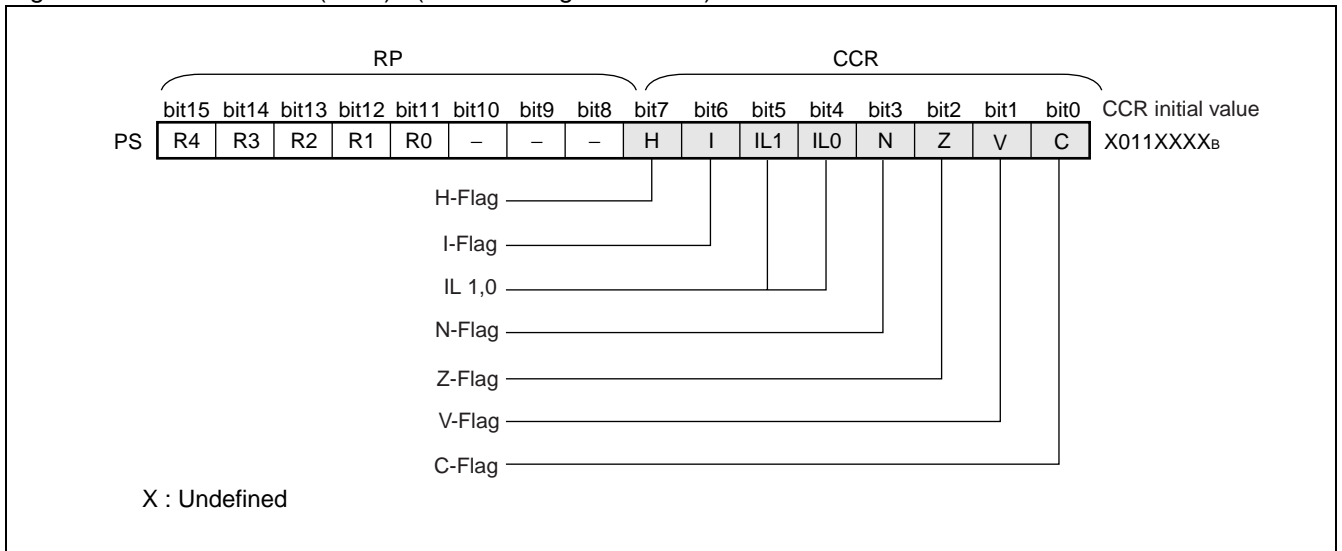

The RP points to the address of the register bank currently in use. The relationship between the pointer contents and the actual address is based on the conversion rule shown next.

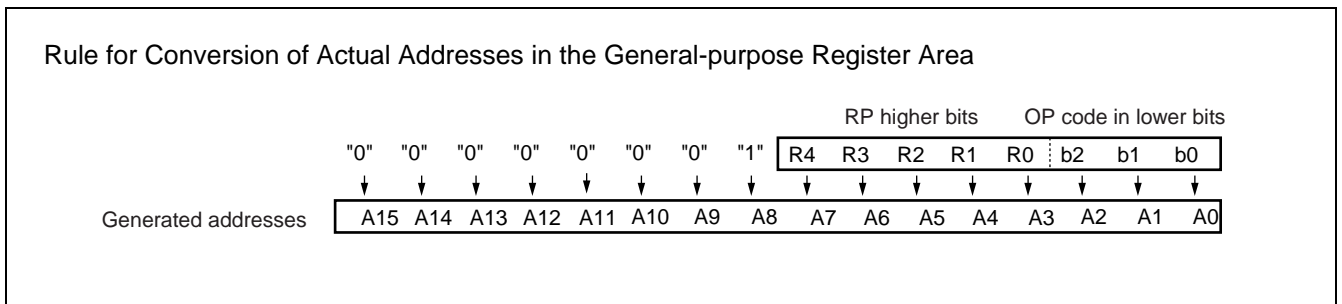

The CCR consists of the bits indicating arithmetic operation results or transfer data contents and the bits that control CPU operations at the time of an interrupt.

- H flag : The flag is set to "1" when an arithmetic operation results in a carry from bit 3 to bit 4 or in a borrow from bit 4 to bit 3. The bit is cleared to "0" in other instances. The flag is for decimal adjustment instructions; do not use for other than additions and subtractions.
- I flag : Interrupt is enabled when this flag is set to "1." Interrupt is disabled when this flag is set to "0." The flag is set to "0" when reset.
- IL1, 0 : Indicates the level of the interrupt currently enabled. An interrupt is processed only if its level is higher than the value this bit indicates.

IL1	IL0	Interrupt level	High-low
0	0	1	Higher
0	1		
1	0	2	Lower = no interruption
1	1	3	

MB89580B/580BW series

- N flag : The flag is set to "1" when an arithmetic operation results in setting of the MSB to "1" or is cleared to "0" when the MSB is set to "1."
- Z flag : The flag is set to "1" when an arithmetic operation results in "0" or is set to "0" in other instances.
- V flag : The flag is set to "1" when an arithmetic operation results in two's complement overflow or is cleared to "0" if no overflow occurs.
- C flag : The flag is set to "1" when an arithmetic operation results in a carry from bit 7 or in a borrow to bit 7. The flag is cleared to "0" if neither of them occurs. In the case of a shift instruction, the flag is set to the shift-out value.

The following general-purpose registers are provided:

- General-purpose registers : 8-bit data storage registers

The general-purpose registers are 8 bits in length and located in the register banks in the memory. One bank contains eight registers and the MB89580B/BW microcontrollers allow a total of 16 banks to be used at maximum.

The bank currently in use is indicated by the register bank pointer (RP) .

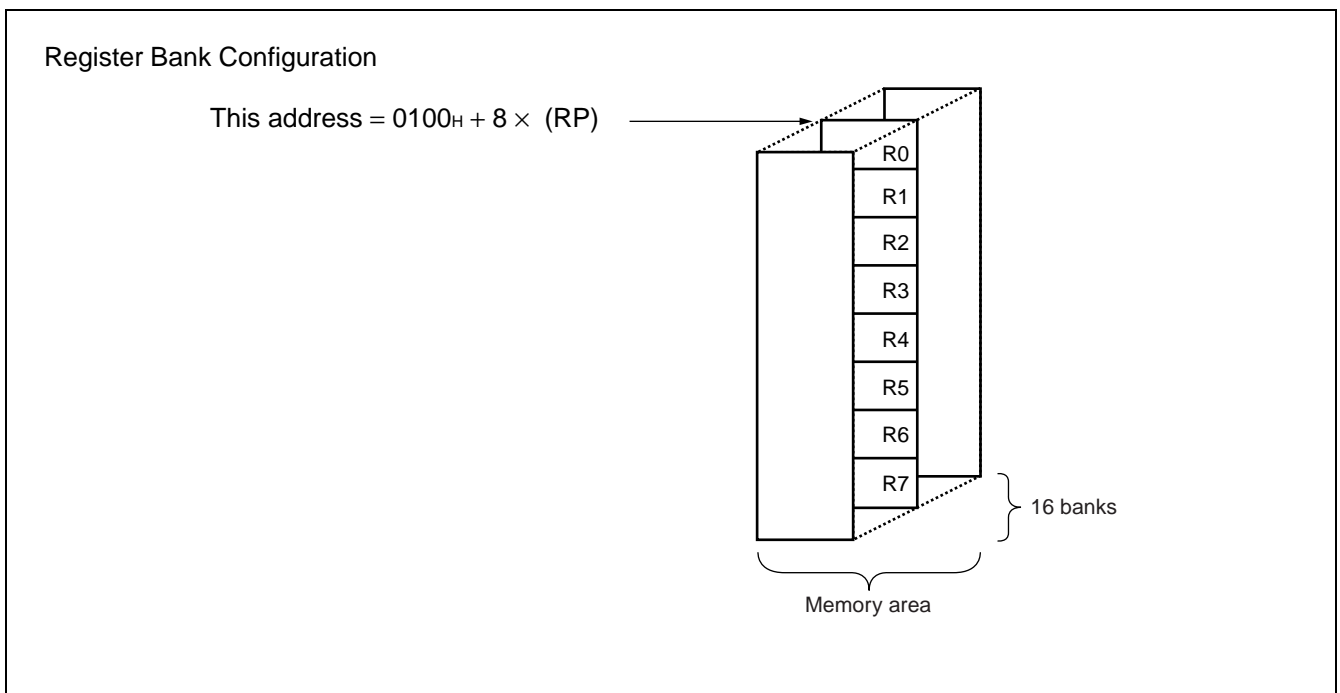

MB89580B/580BW series

■ I/O MAP

Address	Register name	Register description	Read/write	Initial value
00H	PDR0	Port 0 data register	R/W	XXXXXXXX
01H	DDR0	Port 0 direction register	W	00000000
02H	PDR1	Port 1 data register	R/W	XXXXXXXX
03H	DDR1	Port 1 direction register	W	00000000
04H	PDR2	Port 2 data register	R/W	00000000
05H	Vacancy			
06H	Vacancy			
07H	SYCC	System clock control register	R/W	XXX11X00
08H	STBC	Standby control register	R/W	0001XXXX
09H	WDTC	Watchdog timer control register	R/W	0XXXXXXXX
0AH	TBTC	Timebase timer control register	R/W	00XXX000
0BH	Vacancy			
0CH	PDR3	Port 3 data register	R/W	XXXXXXXX
0DH	DDR3	Port 3 direction register	R/W	00000000
0EH	Vacancy			
0FH	Vacancy			
10H	PDR4	Port 4 data register	R/W	XXXXXXXX
11H	DDR4	Port 4 direction register	R/W	00000000
12H	PDR5	Port 5 data register	R/W	XXX111XX
13H	DDR5	Port 5 direction register	R/W	XXXXXX00
14H	PDR6	Port 6 data register	R/W	XXXXXXXX
15H	PDCR	Parallel port data control register	R/W	XXX00000
16H to 20H	Vacancy			
21H	PURR0	Port 0 pullup option setting register	R/W	11111111
22H	PURR1	Port 1 pullup option setting register	R/W	11111111
23H	PURR2	Port 2 pullup option setting register	R/W	11111111
24H	PURR3	Port 3 pullup option setting register	R/W	11111111
25H	PURR4	Port 4 pullup option setting register	R/W	11111111
26H	PURR5	Port 5 pullup option setting register	R/W	XXX11111
27H	CTR1	PWM control register 1	R/W	00000000
28H	CTR2	PWM control register 2	R/W	000X0000
29H	CTR3	PWM control register 3	R/W	X000XXXX
2AH	CMR1	PWM compare register 1	W	XXXXXXXX
2BH	CMR2	PWM compare register 2	W	XXXXXXXX

(Continued)

MB89580B/580BW series

Address	Register name	Register description	Read/write	Initial value
2C _H	CKR	Clock output control register	R/W	XXXXXXXX0
2D _H	SCS	Serial clock switching register	R/W	XXXXXXXX0
2E _H	Vacancy			
2F _H	SMC1	Serial mode control register 1	R/W	00000000
30 _H	SMC2	Serial mode control register 2	R/W	00000000
31 _H	SSD	Serial status and control register	R	00001XXX
32 _H	SIDR/SODR	Serial input/serial output data register	R/W	XXXXXXXXX
33 _H	SRC	Serial rate control register	R/W	XXXXXXXXX
34 _H to 3B _H	Vacancy			
3C _H	EIE	External interrupt control register	R/W	00000000
3D _H	EIF	External interrupt flag register	R/W	XXXXXXXX0
3E _H to 3F _H	Vacancy			
40 _H	DMDR	USB power supply mode register	R/W	XXXXXXXX0
41 _H to 4E _H	Vacancy			
4F _H	DBARH	DMA base address register H	R/W	000000XX
50 _H	UMDR	USB reset mode register	R/W	1000XX00
51 _H	DBAR	DMA base address register	R/W	XXXXXXXXX
52 _H	TDCR0	Transfer data count register 0	R/W	X0000000
53 _H	TDCR11	Transfer data count register 11	R/W	00000000
54 _H	TDCR12	Transfer data count register 12	R/W	XXXXXX00
55 _H	TDCR21	Transfer data count register 21	R/W	00000000
56 _H	TDCR22	Transfer data count register 22	R/W	XXXXXX00
57 _H	TDCR3	Transfer data count register 3	R/W	X0000000
58 _H	UCTR	USB control register	R/W	00000000
59 _H	USTR1	USB status register 1	R/W	00000000
5A _H	USTR2	USB status register 2	R	XXXXXX00
5B _H	UMSKR	USB interrupt mask register	R/W	00000000
5C _H	UFRMR1	USB frame status register 1	R	XXXXXXXXX
5D _H	UFRMR2	USB frame status register 2	R	XXXXXXXXX
5E _H	EPER	USB endpoint enable register	R/W	XXXX0001
5F _H	EPBR0	Endpoint 0 setup register	R/W	X0000000
60 _H	EPBR11	Endpoint setup register 11	R/W	0X000000
61 _H	EPBR12	Endpoint setup register 12	R/W	00000000

(Continued)

MB89580B/580BW series

(Continued)

Address	Register name	Register description	Read/write	Initial value
62 _H	EPBR21	Endpoint setup register 21	R/W	0X000000
63 _H	EPBR22	Endpoint setup register 22	R/W	00000000
64 _H	EPBR31	Endpoint setup register 31	R/W	XX0000XX
65 _H	EPBR32	Endpoint setup register 32	R/W	X0000000
66 _H to 7B _H	Vacancy			
7C _H	ILR1	Interrupt level setting register 1	W	11111111
7D _H	ILR2	Interrupt level setting register 2	W	11111111
7E _H	ILR3	level setting register 3	W	11111111
7F _H	Vacancy			
<ul style="list-style-type: none"> • Information about read/write R/W : Read/write enabled, R : Read only, W : Write only • Information about initial values 0 : The initial value of this bit is "0". 1 : The initial bit of this bit is "1". X : The initial value of this bit is undefined. 				

Note : Vacancies are not for use.

MB89580B/580BW series

■ ELECTRICAL CHARACTERISTICS

1. Absolute Maximum Ratings

($V_{SS} = 0\text{ V}$)

Parameter	Symbol	Value		Unit	Remarks
		Min	Max		
Power supply voltage	V_{CC}	$V_{SS} - 0.3$	$V_{SS} + 6.0$	V	
Input voltage	V_i	$V_{SS} - 0.3$	$V_{CC} + 0.3$	V	Other than P60 to P67
		$V_{SS} - 0.5$	$V_{SS} + 4.0$	V	P60 to P67
Output voltage	V_o	$V_{SS} - 0.3$	$V_{CC} + 0.3$	V	
"L" level average output current	I_{OLAV}	—	4	mA	Average value (operating current × operating rate)
"L" level total maximum output current	ΣI_{OL}	—	100	mA	
"L" level total average output current	ΣI_{OLAV}	—	40	mA	Average value (operating current × operating rate)
"H" level maximum output current	I_{OH}	—	-15	mA	
"H" level average output current	I_{OHAV}	—	-4	mA	Average value (operating current × operating rate)
"H" level total maximum output current	ΣI_{OH}	—	-50	mA	
"H" level total average output current	ΣI_{OHAV}	—	-20	mA	Average value (operating current × operating rate)
Power consumption	P_D	—	300	mW	
Operating temperature	T_A	-40	+85	°C	
Storage temperature	T_{stg}	-55	+150	°C	

WARNING: Semiconductor devices can be permanently damaged by application of stress (voltage, current, temperature, etc.) in excess of absolute maximum ratings. Do not exceed these ratings.

MB89580B/580BW series

2. Recommended Operating Conditions

(V_{SS} = 0 V)

Parameter	Symbol	Value			Unit	Remarks
		Min	Typ	Max		
Power supply voltage	V _{CC}	3.0	—	5.5	V	
Operating temperature	T _A	-40	—	+85	°C	
Smoothing capacitor	C _s	0.1	—	1.0	μF	At V _{CC} = 5.0 V*
Series resistance	R _s	—	16	—	Ω	When the USB function is in use

* : Use either a ceramic capacitor or a capacitor with similar frequency characteristics. The capacity of the smoothing capacitor for the V_{CC} pin should be greater than that of the C_s. When using with a supply voltage of 3.3 V, connect pin C with V_{CC} to input 3.3 V.

- C, RPVP and RPVM Pin Connection Diagram

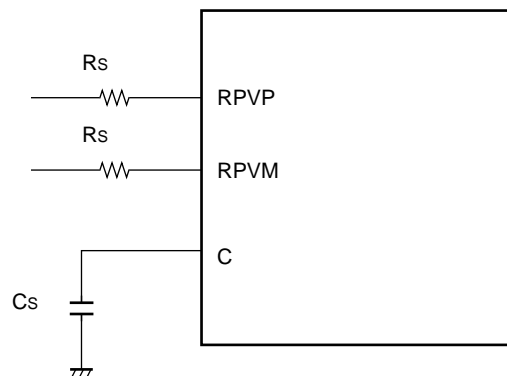

MB89580B/580BW series

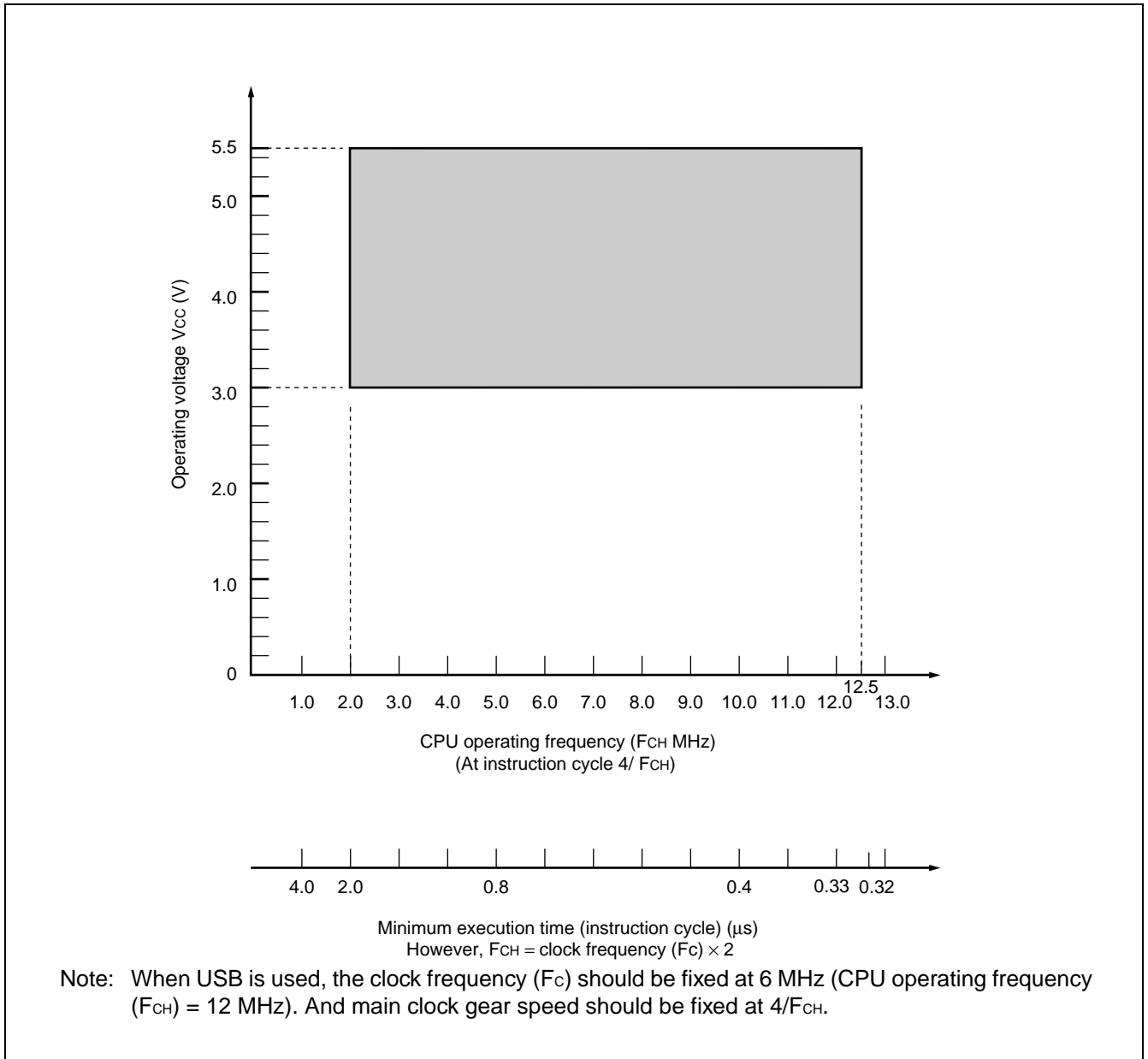

Figure 1 Operating voltage - operating frequency

WARNING: The recommended operating conditions are required in order to ensure the normal operation of the semiconductor device. All of the device's electrical characteristics are warranted when the device is operated within these ranges.

Always use semiconductor devices within their recommended operating condition ranges. Operation outside these ranges may adversely affect reliability and could result in device failure.

No warranty is made with respect to uses, operating conditions, or combinations not represented on the data sheet. Users considering application outside the listed conditions are advised to contact their FUJITSU representatives beforehand.

MB89580B/580BW series

3. DC Characteristics

($V_{CC} = 5.0\text{ V}$, $V_{SS} = 0\text{ V}$, $T_A = -40\text{ }^\circ\text{C}$ to $+85\text{ }^\circ\text{C}$)

Parameter	Symbol	Pin name	Condition	Value			Unit	Remarks
				Min	Typ	Max		
“H” level input voltage	V_{IH}	P00 to P07, P10 to P17, P20 to P27, P30 to P37, P40 to P47, P50 to P54, MOD0, MOD1	—	$0.7 V_{CC}$	—	$V_{CC} + 0.3$	V	
	V_{IHS}	\overline{RST} , $\overline{INT0}$ to $\overline{INT7}$, UCK, UI	—	$0.8 V_{CC}$	—	$V_{CC} + 0.3$	V	
	V_{IH1}	P60 to P67	—	$V_{SS} + 2.0$	—	$V_{SS} + 3.6$	V	
“L” level input voltage	V_{IL}	P00 to P07, P10 to P17, P20 to P27, P30 to P37, P40 to P47, P50 to P54, MOD0, MOD1	—	$V_{SS} - 0.3$	—	$0.3 V_{CC}$	V	
	V_{ILS}	\overline{RST} , $\overline{INT0}$ to $\overline{INT7}$, UCK, UI	—	$V_{SS} - 0.3$	—	$0.2 V_{CC}$	V	
	V_{IL1}	P60 to P67	—	$V_{SS} - 0.5$	—	$V_{SS} + 0.8$	V	
Open-drain output application voltage	V_{D1}	P52 to P54	—	$V_{SS} - 0.3$	—	$V_{CC} + 0.3$	V	
“H” level output voltage	V_{OH}	P00 to P07, P10 to P17, P20 to P24, P30 to P37, P40 to P47, P50, P51	$I_{OH} = -2.0\text{ mA}$	4.0	—	—	V	
“L” level output voltage	V_{OL}	P00 to P07, P10 to P17, P20 to P24, P30 to P37, P40 to P47, P50 to P54, \overline{RST}	$I_{OL} = 4.0\text{ mA}$	—	—	0.4	V	

(Continued)

MB89580B/580BW series

(Continued)

($V_{CC} = 5.0\text{ V}$, $V_{SS} = 0\text{ V}$, $T_A = -40\text{ }^\circ\text{C}$ to $+85\text{ }^\circ\text{C}$)

Parameter	Symbol	Pin name	Condition	Value			Unit	Remarks
				Min	Typ	Max		
Input leakage current (Hi-Z output leakage current)	I_{LI}	P00 to P07, P10 to P17, P20 to P27, P30 to P37, P40 to P47, P50, P51, P60 to P67	$0.0 < V_I < V_{CC}$	-5	—	+5	μA	When no pullup resistance is specified
Open-drain output leakage current	I_{LIOD}	P52 to P54	$0.0 < V_I < V_{SS} + 5.5$	—	—	+5	μA	
Pullup resistance	R_{PULL}	P00 to P07, P10 to P17, P20 to P27, P30 to P37, P40 to P47, P50 to P54, $\overline{\text{RST}}$	$V_I = 0.0\text{ V}$	25	50	100	$\text{k}\Omega$	$\overline{\text{RST}}$ is excluded when pullup resistance available is specified.
Power supply current	I_{CC}	V_{CC}	$F_{CH} = 12.0\text{ MHz}$ $V_{CC} = 5.0\text{ V}$ $t_{inst} = 0.333\text{ }\mu\text{s}$	—	25	38	mA	MB89P585B/BW, MB89585B/BW, MB89583B/BW MB89P589B, MB89589B
	I_{CCS1}		$F_{CH} = 12.0\text{ MHz}$ $V_{CC} = 5.0\text{ V}$ $t_{inst} = 0.333\text{ }\mu\text{s}$	—	20	30	mA	Sleep mode
	I_{CCH}		$T_A = 25\text{ }^\circ\text{C}$	—	5	20	μA	Stop
Input capacitance	C_{IN}	Other than V_{CC} and V_{SS}	$f = 1\text{ MHz}$	—	10	—	pF	

MB89580B/580BW series

4. AC Characteristics

(1) Reset Timing

($V_{CC} = 5.0\text{ V}$, $V_{SS} = 0\text{ V}$, $T_A = -40\text{ }^\circ\text{C}$ to $+85\text{ }^\circ\text{C}$)

Parameter	Symbol	Condition	Value		Unit	Remarks
			Min	Max		
RST "L" pulse width	tZLZH	—	48 t _{HCLY}	—	ns	

Note : t_{HCLY} is the internal main clock oscillating cycle (1/2 F_c) .

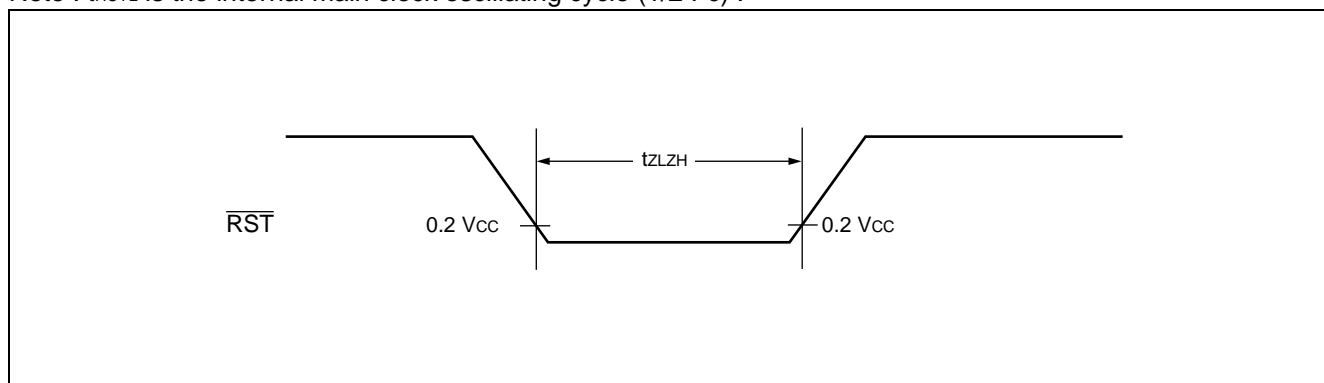

(2) Power-on Reset and Power On Time

($V_{SS} = 0\text{ V}$, $T_A = -40\text{ }^\circ\text{C}$ to $+85\text{ }^\circ\text{C}$)

Parameter	Symbol	Condition	Value		Unit	Remarks
			Min	Max		
Power supply rising time	t _R	—	0.066	50	ms	
Power supply cutoff time	t _{OFF}	—	4	—	ns	Due to repeated operations

Note : The power supply must be up within the selected oscillation stabilization time.

When the supply voltage needs to be varied while operating, it is recommended to smoothly start up the voltage.

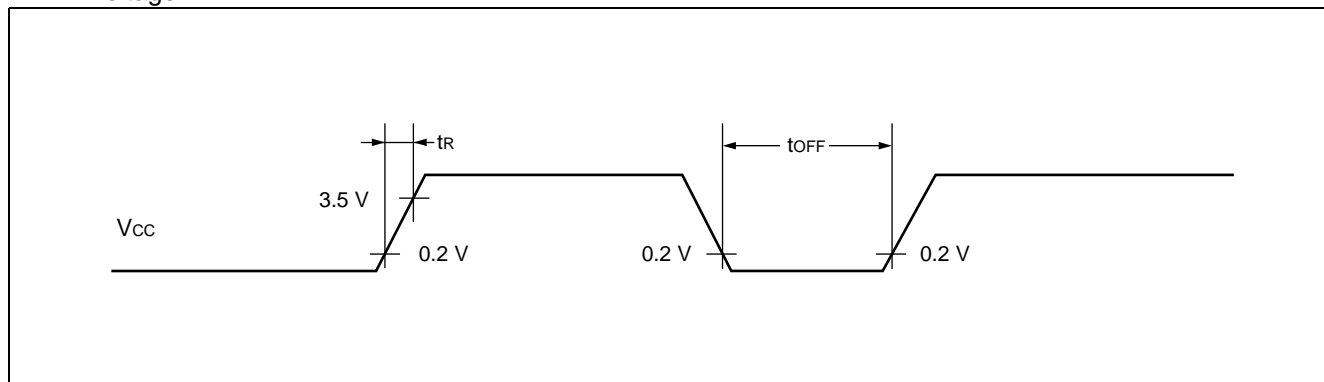

MB89580B/580BW series

(3) Clock Timing

($V_{SS} = 0\text{ V}$, $T_A = -40\text{ }^\circ\text{C}$ to $+85\text{ }^\circ\text{C}$)

Parameter	Symbol	Pin name	Condition	Value			Unit	Remarks
				Min	Typ	Max		
Clock frequency	F_C	X0, X1	—	1	6	6.25	MHz	
Clock cycle time	t_{XCYL}	X0, X1		160	166.6	1000	ns	
Internal main clock frequency	F_{CH}	—		2	12	12.5	MHz	Twice the F_C
Internal clock cycle	t_{HCYL}	—		80	83.3	500	ns	$t_{XCYL}/2$

Note: When USB is used, the clock frequency (F_C) should be fixed at 6 MHz (CPU operating frequency (F_{CH}) = 12 MHz). And main clock gear speed should be fixed at $4/F_{CH}$.

• X0 and X1 Timing and Conditions

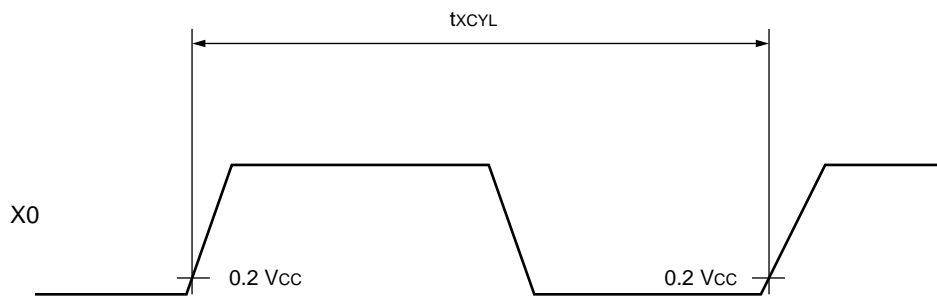

• Clock Conditions

When a crystal resonator is used

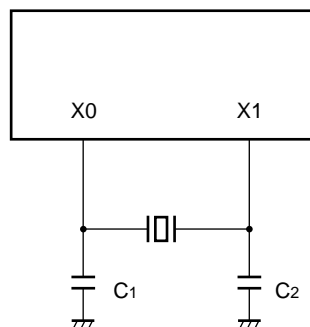

(4) Instruction Cycle

($V_{SS} = 0\text{ V}$, $T_A = -40\text{ }^\circ\text{C}$ to $+85\text{ }^\circ\text{C}$)

Parameter	Symbol	Value	Unit	Remarks
Instruction cycle (Min execution time)	t_{inst}	$4 / F_{CH}$, $8 / F_{CH}$, $16 / F_{CH}$, $64 / F_{CH}$	μS	When operating at $F_{CH} = 12\text{ MHz}$ $t_{inst} = 0.33\text{ } \mu\text{S}$ ($4 / F_{CH}$)

MB89580B/580BW series

(5) UART Serial I/O Timing

($V_{CC} = 5.0\text{ V}$, $V_{SS} = 0\text{ V}$, $T_A = -40\text{ }^\circ\text{C}$ to $+85\text{ }^\circ\text{C}$)

Parameter	Symbol	Pin name	Condition	Value		Unit	Remarks
				Min	Max		
Serial clock cycle time	t_{SCYC}	UCK	Internal shift clock mode	$2 t_{inst}^*$	—	μs	
UCK $\downarrow \rightarrow$ UO	t_{SLOV}	UCK, UO		-200	200	ns	
Valid UI \rightarrow UCK \uparrow	t_{IVSH}	UI, UCK		200	—	ns	
UCK $\uparrow \rightarrow$ valid UI hold time	t_{SHIX}	UCK, UI		200	—	ns	
Serial clock "H" pulse width	t_{SHSL}	UCK	External shift clock mode	$1 t_{inst}^*$	—	μs	
Serial clock "L" pulse width	t_{SLSH}			$1 t_{inst}^*$	—	μs	
UCK $\downarrow \rightarrow$ UO time	t_{SLOV}	UCK, UO		0	200	ns	
Valid UI \rightarrow UCK \uparrow	t_{IVSH}	UI, UCK		200	—	ns	
UCK $\uparrow \rightarrow$ valid UI hold time	t_{SHIX}	UCK, UI		200	—	ns	

* : For information about t_{inst} , see "Instruction Cycle."

• Internal shift clock mode

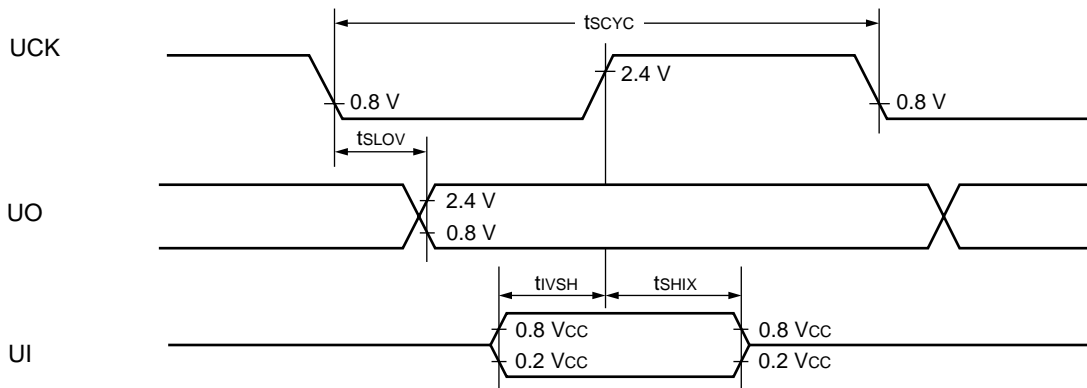

• External shift clock mode

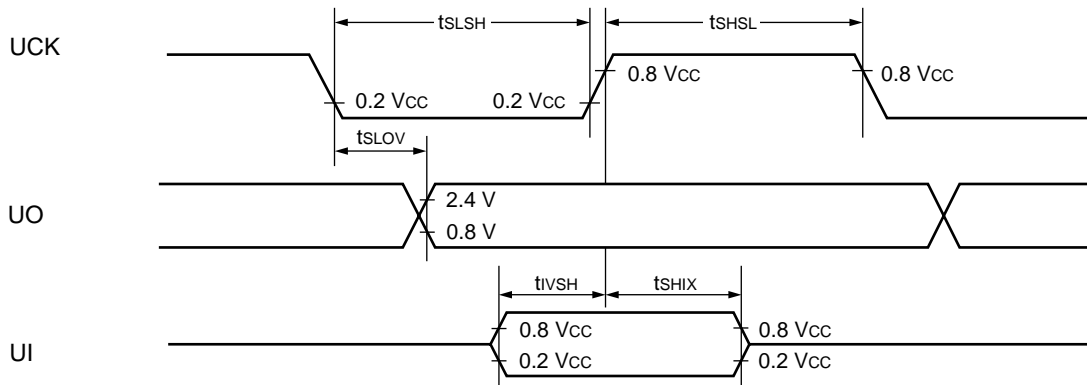

MB89580B/580BW series

(6) Peripheral Input Timing

($V_{CC} = 5.0\text{ V}$, $V_{SS} = 0\text{ V}$, $T_A = -40\text{ }^\circ\text{C}$ to $+85\text{ }^\circ\text{C}$)

Parameter	Symbol	Pin name	Condition	Value		Unit	Remarks
				Min	Max		
Peripheral input "H" pulse width 1	t_{LIH1}	$\overline{\text{INT0}}$ to $\overline{\text{INT7}}$	—	$2 t_{inst}^*$	—	μs	
Peripheral input "L" pulse width 1	t_{HIL1}		—	$2 t_{inst}^*$	—	μs	

* : For information about t_{inst} , see "Instruction Cycle."

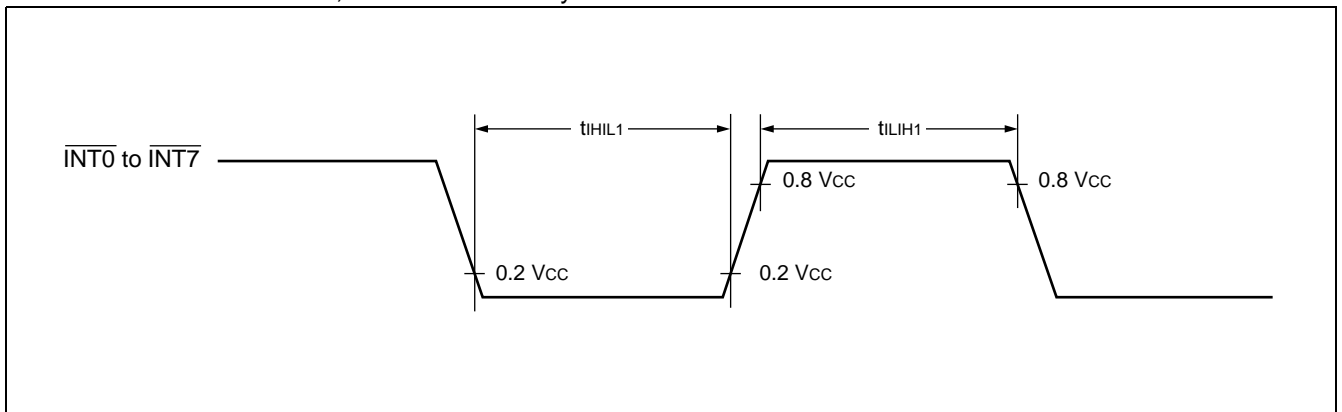

MB89580B/580BW series

(7) Parallel Port Timing

($V_{CC} = 5.0\text{ V}$, $V_{SS} = 0\text{ V}$, $T_A = -40\text{ }^{\circ}\text{C}$ to $+85\text{ }^{\circ}\text{C}$)

Parameter	Symbol	Pin name	Condition	Value		Unit	Remarks
				Min	Max		
IBFX $\uparrow \rightarrow$ WEX \downarrow timing	$t_{IH\text{WL}}$	IBFX WEX	—	$1 / 2 \cdot t_{\text{inst}}$	—	μs	
CEX $\downarrow \rightarrow$ WEX \downarrow delay	$t_{CL\text{WL}}$	CEX WEX	—	0	—	ns	
WEX $\uparrow \rightarrow$ CEX \uparrow delay	$t_{WH\text{CH}}$	CEX WEX	—	0	—	ns	
WEX pulse width	$t_{WL\text{WH}}$	WEX	—	40	—	ns	
Write data setup	$t_{DV\text{WH}}$	D0 to D7 WEX	—	10	—	ns	
Write data hold	$t_{WH\text{DX}}$	D0 to D7 WEX	—	10	—	ns	
Write address setup	$t_{AV\text{WH}}$	A0 WEX	—	10	—	ns	
Write address hold	$t_{WH\text{AX}}$	A0 WEX	—	10	—	ns	
OBF $\uparrow \rightarrow$ RDX \downarrow timing	$t_{OH\text{RL}}$	OBF RDX	—	$1 / 2 \cdot t_{\text{inst}}$	—	μs	
CEX $\downarrow \rightarrow$ RDX \downarrow delay	$t_{CL\text{RL}}$	CEX RDX	—	0	—	ns	
RDX $\uparrow \rightarrow$ CEX \uparrow delay	$t_{RH\text{CH}}$	CEX RDX	—	0	—	ns	
RDX pulse width	$t_{RL\text{RH}}$	RDX	—	40	—	ns	
Read data delay	$t_{RL\text{DV}}$	D0 to D7 RDX	—	—	15	ns	
Read data hold	$t_{RH\text{DX}}$	D0 to D7 RDX	—	0	—	ns	
Read address setup	$t_{AV\text{RL}}$	A0 RDX	—	10	—	ns	
Read address hold	$t_{RH\text{AX}}$	A0 RDX	—	10	—	ns	

MB89580B/580BW series

• Write Timing

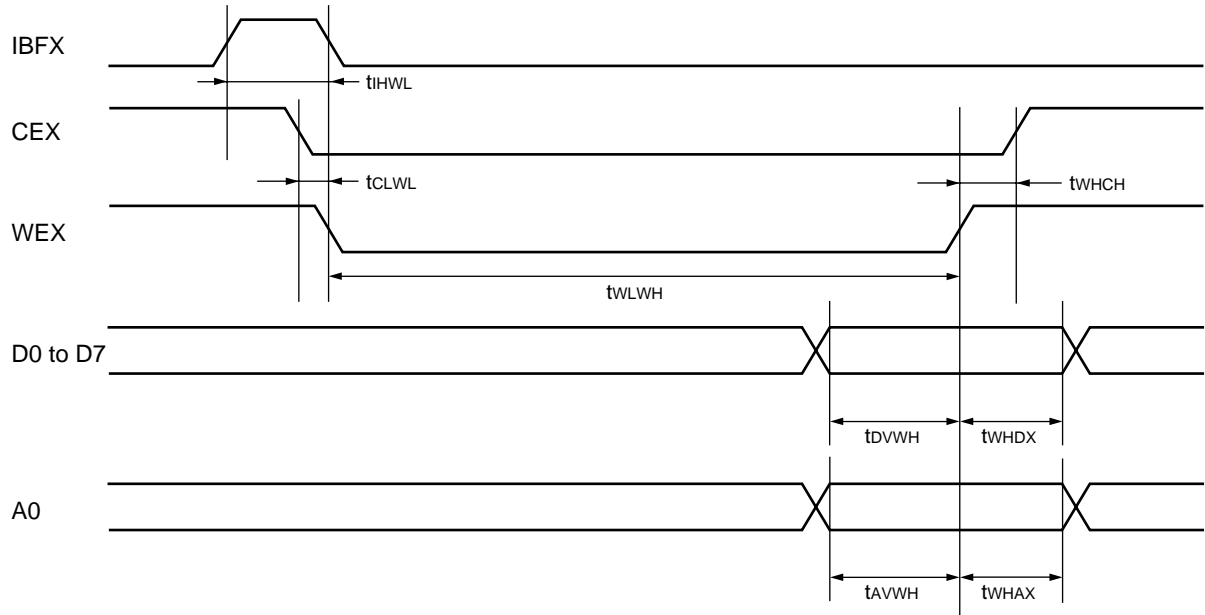

• Read Timing

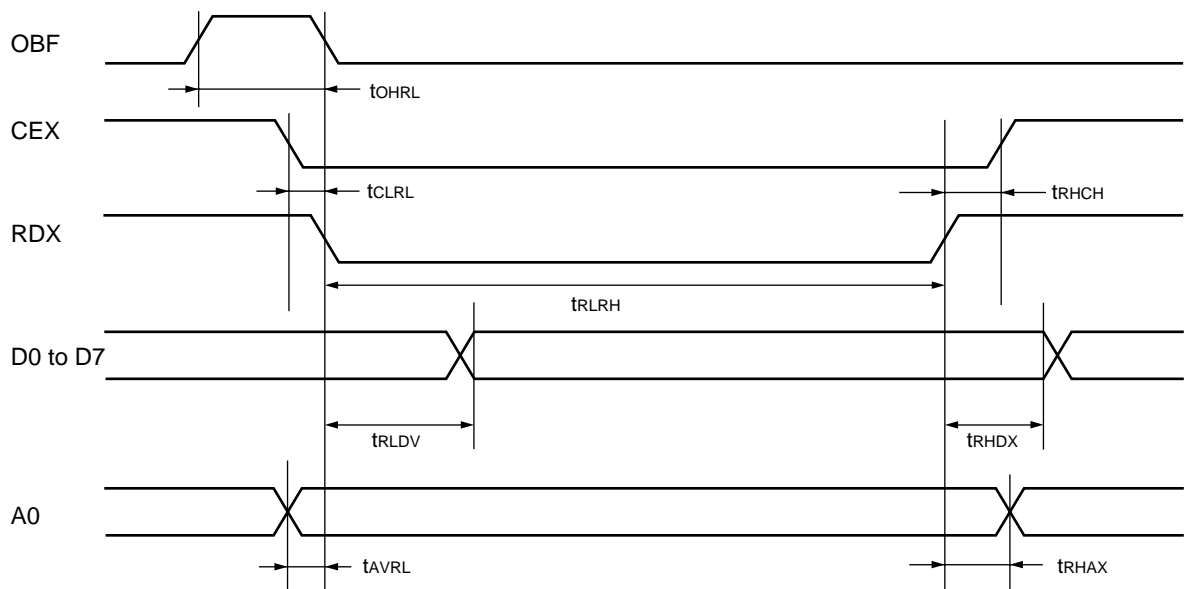

MB89580B/580BW series

(8) External FIFO Connection Timing

($V_{CC} = 5.0\text{ V}$, $V_{SS} = 0\text{ V}$, $T_A = -40\text{ }^\circ\text{C}$ to $+85\text{ }^\circ\text{C}$, $F_C = 6\text{ MHz}$)

Parameter	Symbol	Pin name	Condition	Value		Unit	Remarks
				Min	Max		
FIFO empty resetting timing	t_{EFXH}	EFX	Not including the initial resetting after reset	0	—	ns	Resetting before PKEND is not allowed.
FIFO empty timing	t_{EFL}	EFX, R	—	0	360	ns	
Read cycle time	t_{RSCY}	R	—	645	—	ns	
Read clock "H" pulse width	t_{RHWD}		—	145	—	ns	
Valid DI \rightarrow R \downarrow setup time	t_{DISP}	DI7 to DI0, R	—	50	—	ns	
R \downarrow \rightarrow valid DI hold time	t_{DIHD}		—	0	—	ns	
FIFO full reset timing	t_{FFXH}	FFX	—	0	—	ns	Resetting before PKEND is not allowed.
FIFO full timing	t_{FFL}	FFX, W	—	0	360	ns	
Write cycle time	t_{WSCY}	W	—	645	—	ns	
Write clock "H" pulse width	t_{WHWD}		—	145	—	ns	
Valid DO \rightarrow W \uparrow setup time	t_{DOSP}	DO7 to DO0, W	—	200	—	ns	
W \downarrow \rightarrow valid DO hold time	t_{DOHD}		—	40	—	ns	

MB89580B/580BW series

- Read Data from External FIFO

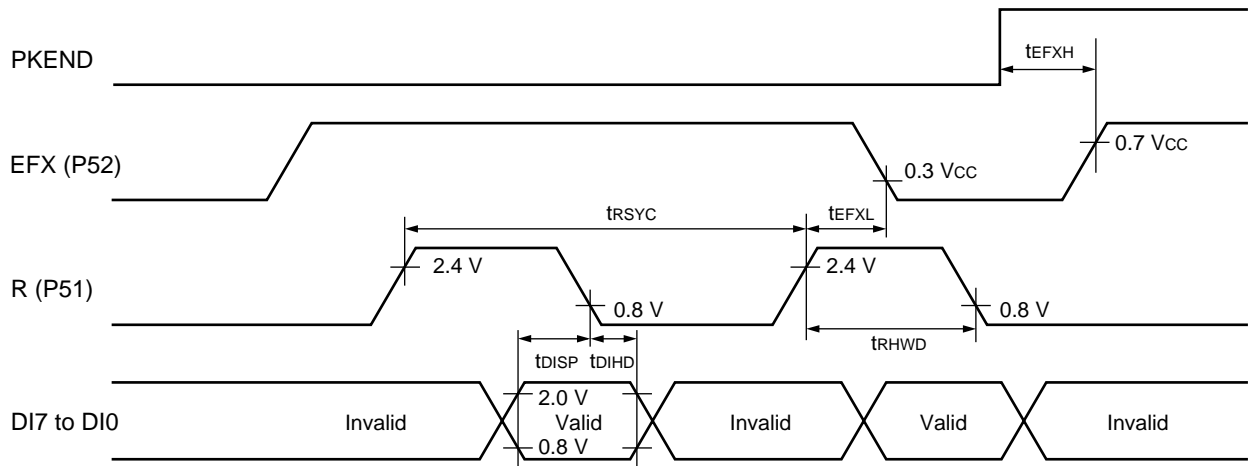

- Write Data to External FIFO

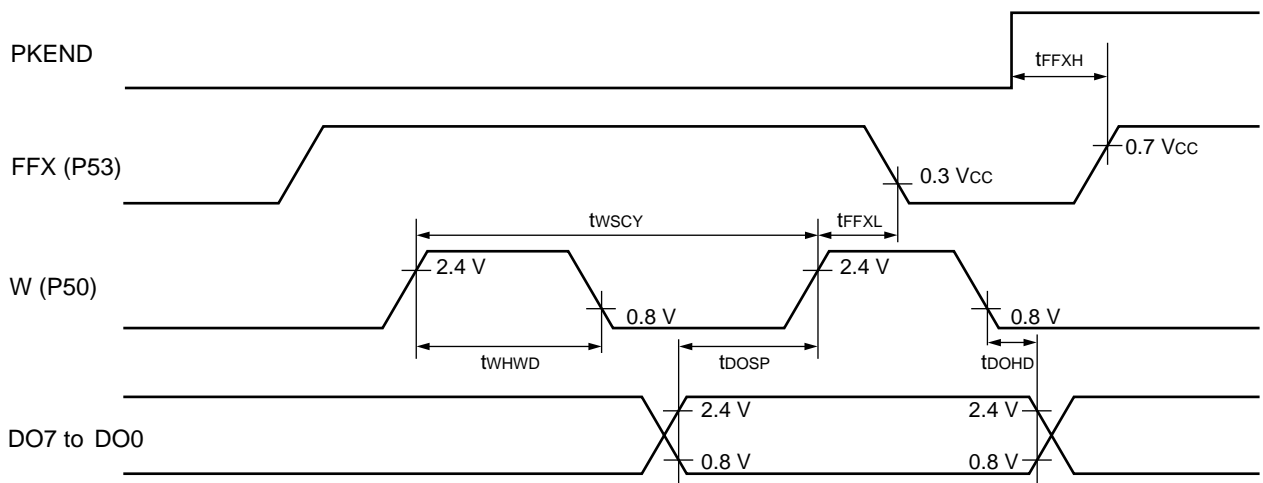

MB89580B/580BW series

■ ORDERING INFORMATION

Part number	Package	Remarks
MB89589BPFM MB89P589BPFM	64-pin plastic LQFP (FPT-64P-M09)	
MB89583BPFV MB89585BPFV MB89P585BPFV MB89583BWPFV MB89585BWPFV MB89P585BWPFV	64-pin plastic LQFP (FPT-64P-M03)	

MB89580B/580BW series

■ PACKAGE DIMENSIONS

64-pin plastic LQFP
(FPT-64P-M03)

Note: Pins width and pins thickness include plating thickness.

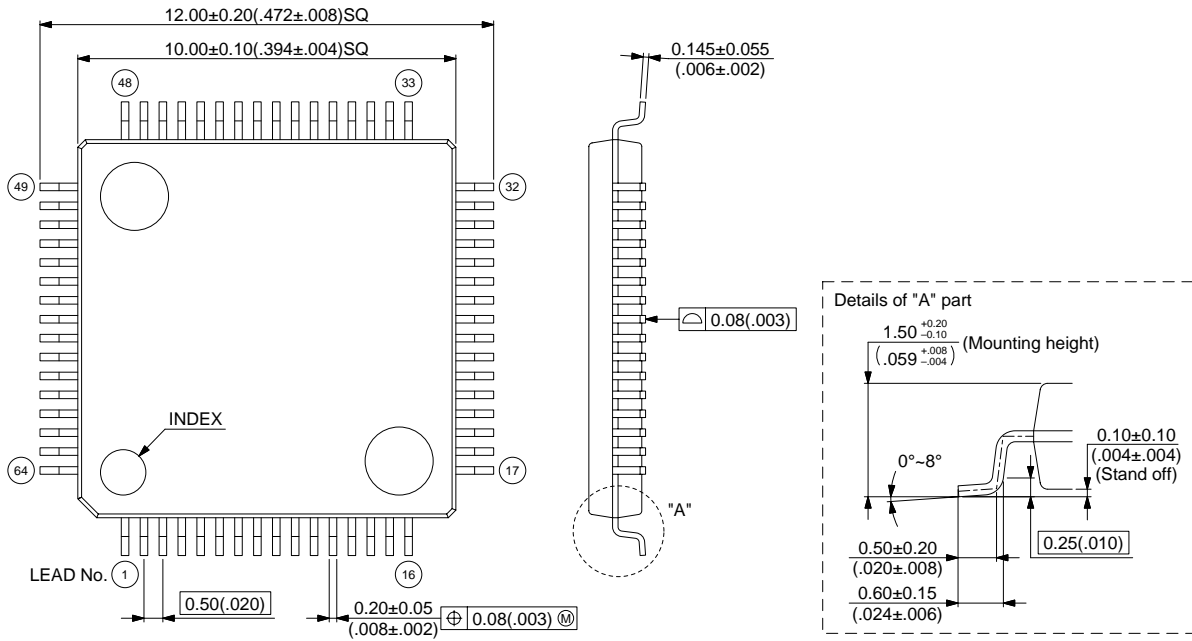

© 2000 FUJITSU LIMITED F64009S-c-4-7

Dimensions in mm (inches)

(Continued)

MB89580B/580BW series

(Continued)

64-pin plastic LQFP
(FPT-64P-M09)

Note: Pins width and pins thickness include plating thickness.

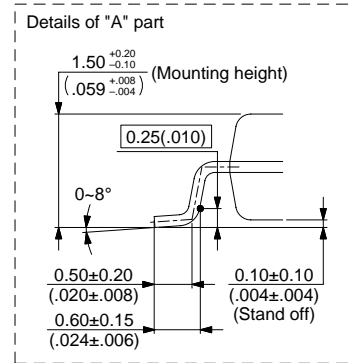
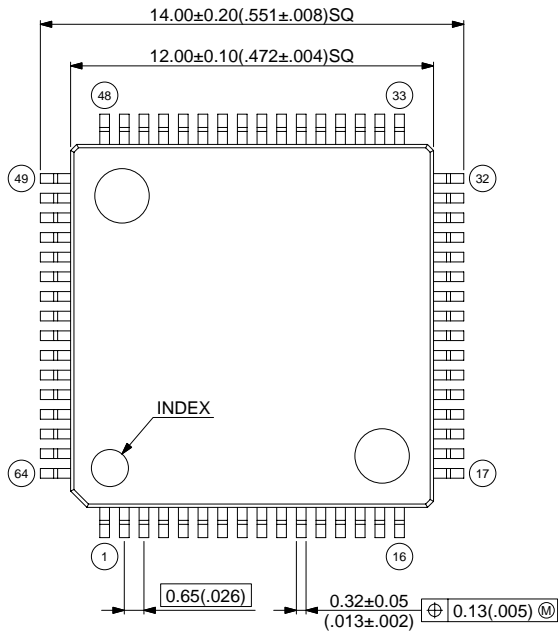

© 2001 FUJITSU LIMITED F64018S-c-2-4

Dimensions in mm (inches)

MB89580B/580BW series

FUJITSU LIMITED

All Rights Reserved.

The contents of this document are subject to change without notice. Customers are advised to consult with FUJITSU sales representatives before ordering.

The information and circuit diagrams in this document are presented as examples of semiconductor device applications, and are not intended to be incorporated in devices for actual use. Also, FUJITSU is unable to assume responsibility for infringement of any patent rights or other rights of third parties arising from the use of this information or circuit diagrams.

The products described in this document are designed, developed and manufactured as contemplated for general use, including without limitation, ordinary industrial use, general office use, personal use, and household use, but are not designed, developed and manufactured as contemplated (1) for use accompanying fatal risks or dangers that, unless extremely high safety is secured, could have a serious effect to the public, and could lead directly to death, personal injury, severe physical damage or other loss (i.e., nuclear reaction control in nuclear facility, aircraft flight control, air traffic control, mass transport control, medical life support system, missile launch control in weapon system), or (2) for use requiring extremely high reliability (i.e., submersible repeater and artificial satellite).

Please note that Fujitsu will not be liable against you and/or any third party for any claims or damages arising in connection with above-mentioned uses of the products.

Any semiconductor devices have an inherent chance of failure. You must protect against injury, damage or loss from such failures by incorporating safety design measures into your facility and equipment such as redundancy, fire protection, and prevention of over-current levels and other abnormal operating conditions.

If any products described in this document represent goods or technologies subject to certain restrictions on export under the Foreign Exchange and Foreign Trade Law of Japan, the prior authorization by Japanese government will be required for export of those products from Japan.