

PZTA42

■ Features

- High breakdown voltage
- Low collector-emitter saturation voltage
- Complementary to PZTA92(PNP)

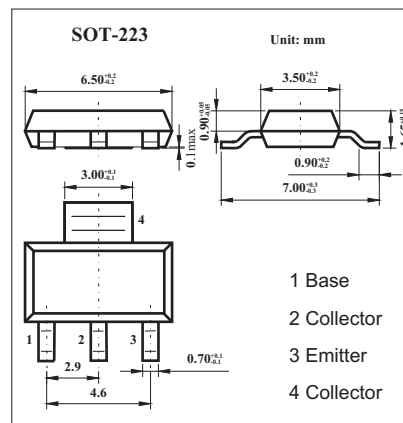

■ Absolute Maximum Ratings Ta = 25°C

Parameter	Symbol	Rating	Unit
Collector-Base Voltage	V _{CB0}	300	V
Collector-Emitter Voltage	V _{CEO}	300	V
Emitter-Base Voltage	V _{EBO}	6	V
Collector Current -Continuous	I _C	500	mA
Collector Power Dissipation	P _C	1	W
Junction Temperature	T _j	150	°C
Storage Temperature	T _{stg}	-55 to 150	°C

■ Electrical Characteristics Ta = 25°C

Parameter	Symbol	Test conditions	Min	Typ	Max	Unit
Collector-to-base breakdown voltage	V _{(BR)CBO}	I _C = 100 μA, I _E =0	300			V
Collector-to-emitter breakdown voltage	V _{(BR)CEO}	I _C = 1 mA, I _B =0	300			V
Emitter-to-base breakdown voltage	V _{(BR)EBO}	I _E = 100 μA, I _C =0	6			V
Collector cutoff current	I _{CBO}	V _{CB} = 200 V, I _E =0			0.1	μA
Emitter cutoff current	I _{EBO}	V _{EB} = 6V, I _C =0			0.1	μA
DC current gain	h _{FE}	V _{CE} = 10V, I _C = 1mA	25			
		V _{CE} = 10V, I _C = 10mA	40			
		V _{CE} = 10V, I _C = 30mA	40			
Collector-emitter saturation voltage	V _{CE(sat)}	I _C =20 mA, I _B = 2mA			0.5	V
Base-emitter saturation voltage	V _{BE(sat)}	I _C = 20 mA, I _B = 2mA			0.9	V
Output Capacitance	C _{ob}	V _{CB} = 20V, f = 1.0MHz, I _E = 0			3.0	pF
Transition frequency	f _T	V _{CE} = 20V, I _C = 10mA, f=100MHz	50			MHz

■ Marking

Marking	A42
---------	-----