

Frontplattenausschnitt (Rückseite)
Panel cut out (rear side)

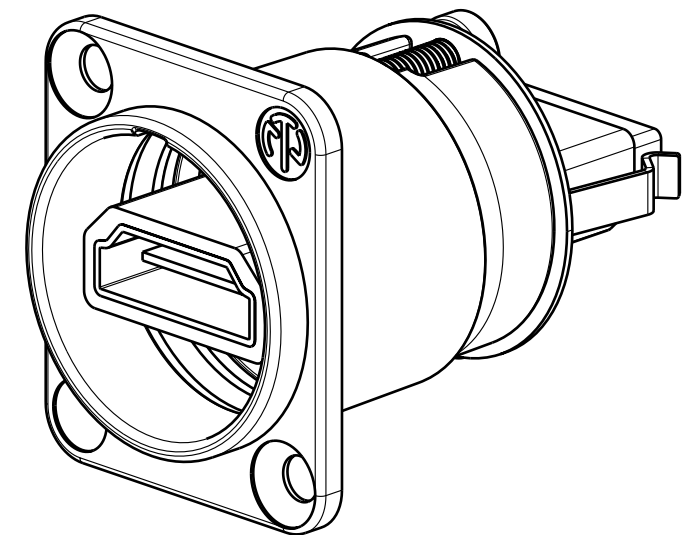
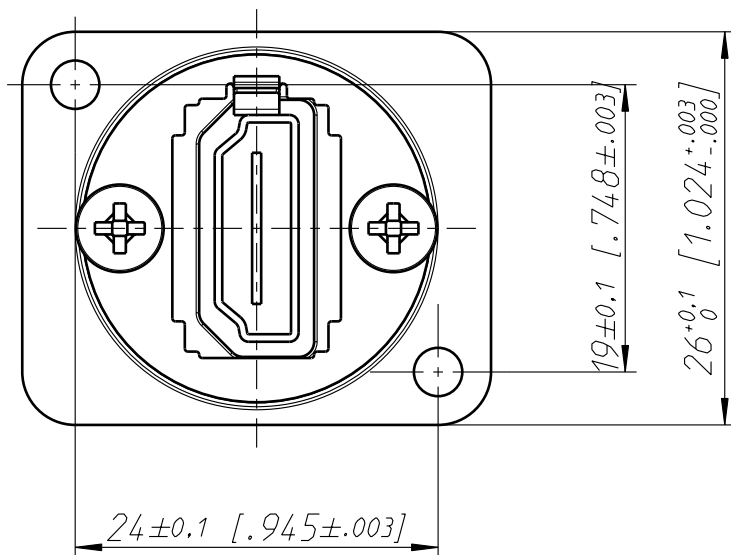
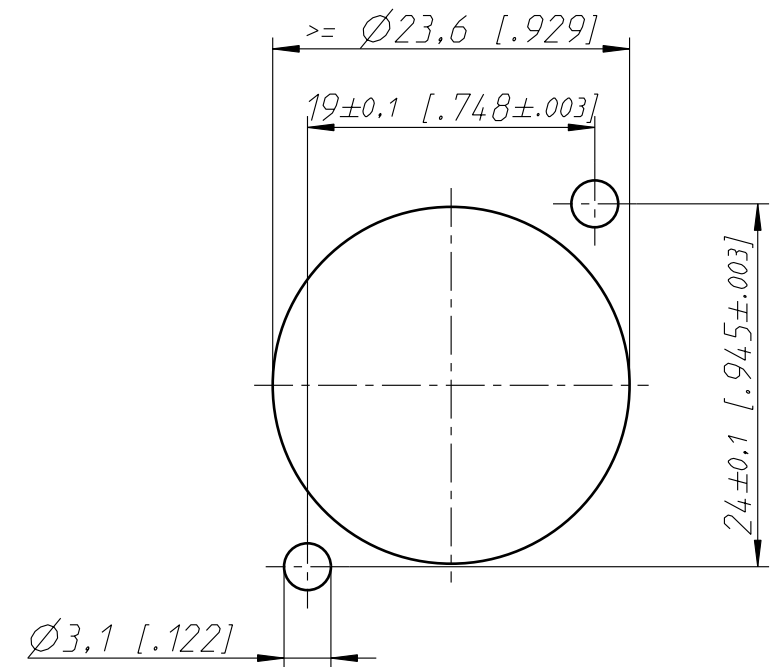

Allgemeintoleranzen ISO 2768-m	Werkstoff	Massstab:	Datum	Name
Zeichnung urheberrechtlich geschuetzt (DIN 34) (C)	-	2:1 (A3)	14.05.08	Mijatovic
Benennung	NA1394-6-W NAHDMI-W		Gezeichnet	
			Freigegeben	
			Geaendert	-
			Aend.-Nr.	Aend.-Index
			-	-
			Ersatz fuer:	Blatt 1 von 1 Bl.
			Zeichn. Nr.	
				ST-NAHDMI-W