

UNLESS OTHERWISE NOTED
 DIMENSIONS ARE IN INCHES TOLERANCES ARE:
 ONE PLACE DECIMALS: ± .1 [2.54] THREE PLACE DECIMALS: ± .005 [.127]
 TWO PLACE DECIMALS: ± .01 [.25] FOUR PLACE DECIMALS: ± .0020 [.0508] ANGLES ± 1°

TITLE: .050 X .100
 EDGE MOUNT
 (STRADDLE)

DWG NO: HTMS-1XX-XX-XX-D-EM-XX
 SHEET 1 OF 1

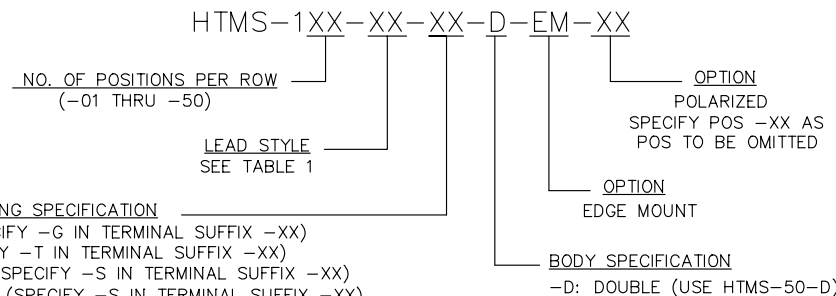
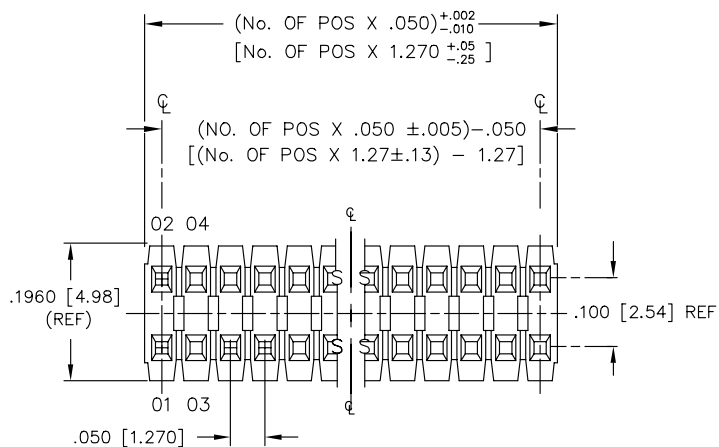

- PLATING SPECIFICATION
- G: GOLD (SPECIFY -G IN TERMINAL SUFFIX -XX)
 - T: TIN (SPECIFY -T IN TERMINAL SUFFIX -XX)
 - S: SELECTIVE (SPECIFY -S IN TERMINAL SUFFIX -XX)
 - SM: SELECTIVE (SPECIFY -S IN TERMINAL SUFFIX -XX)
 - TM: MATTE TIN (SPECIFY -T IN TERMINAL SUFFIX -XX)

NOTES:

1. MAX ALLOWABLE BOW: .005 INCH/INCH.
2. TERMINAL PUSHOUT FORCE: 2 lbs. MIN.
3. Ⓞ REPRESENTS A CRITICAL DIMENSION FOR STATISTICAL PROCESS CONTROL USE.
4. ALL DIM IN BRACKETS [] TO BE IN MILLIMETERS.
5. PARTS ARE TO BE PACKAGED IN A PT-1-24-01-29 TUBE AND TWO TP-03 PLUGS PER TUBE.
6. CUT FLASH .010 MAX.
7. POSITIONS -08 THROUGH -50 ARE TO BE PACKAGED IN TUBES; POSITIONS -01 THROUGH -07 ARE TO BE LAYER PACKAGED.

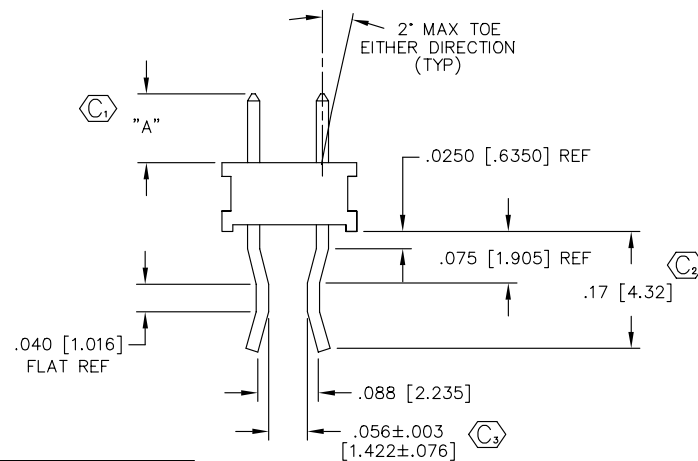
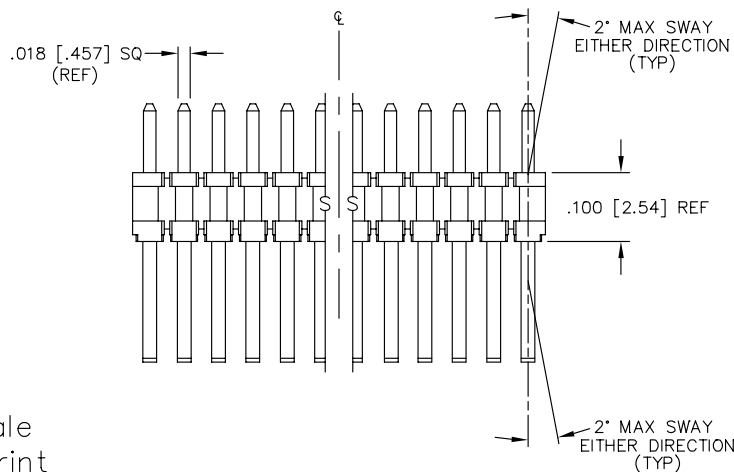

Do not scale from this print

TABLE 1

TERMINAL SPECIFICATION		
LEAD STYLE	TERMINAL	"A" POST HEIGHT
-01	T-1M6-04-XX-X	.230 [5.842]
-02	T-1M6-26-XX-X	.100 [2.540]
-03	T-1M6-27-XX-X	.125 [3.175]

TABLE 2

LENGTH	"L"	LENGTH	"L"
-01	.440 [11.18]	-16	.825 [20.96]
-02	.410 [10.41]	-17	.320 [8.13]
-03	.610 [15.49]	-18	.450 [11.43]
-04	.505 [12.83]	-19	.650 [16.51]
-05	.705 [17.91]	-21	.505 [12.83]
-12	.425 [10.80]	-25	.330 [8.38]
-13	.625 [15.88]	-26	.373 [9.47]
-14	.555 [14.10]	-27	.398 [10.11]
-15	.755 [19.18]	-28	1.050 [26.67]

* REF FOR PIN LENGTH

PLOT SCALE: 1=.1428

PROPRIETARY NOTE
 THIS DOCUMENT CONTAINS INFORMATION CONFIDENTIAL AND PROPRIETARY TO SAMTEC INC. AND SHALL NOT BE REPRODUCED OR TRANSFERRED TO OTHER DOCUMENTS OR DISCLOSED TO OTHERS OR USED FOR ANY PURPOSE OTHER THAN THAT FOR WHICH IT WAS OBTAINED WITHOUT THE EXPRESSED WRITTEN CONSENT OF SAMTEC INC.



520 PARK EAST BLVD. NEW ALBANY, INDIANA 47150
 PHONE (812) 944-6733 P.O. BOX 1147
 CODE 55322

MADE BY: GARY PURVIS 12-4-92

HTMS-1XX-XX-XX-D-EM-XX
 SHEET 1 OF 1