

SPECIFICATION

- Model No. : **SGGP.18A**
- Product Name : **GPS/GLONASS SMT Patch Antenna**
- Features : 18mm*18mm*4mm
Single Feed SMT
GPS: 1575MHz
GLONASS: 1602MHz
Patent pending
- RoHS ✓
- Photo :



1. Introduction

This ceramic 18mm GPS/GLONASS patch antenna is mounted via SMT process and has been pre-tuned for a 50*50mm ground plane. Custom part no's tuned for different ground-plane or layout positions and taking into account the specific conditions in your device can be created and supplied by Taoglas.

2. Specification

Original Patch Specification tested on 50*50mm ground plane

No	Parameter	Specification	Notes
1	Range of Receiving Frequency	GPS:1575.42 MHz ± 1.023 MHz GLONASS: 1602± 5 MHz	
2	Center Frequency	1592± 3MHz	With 50*50mm ground plane
3	Bandwidth	8MHz min	Return Loss <-10 dB
4	VSWR	1.5 max	Center Frequency
5	Gain at Zenith	GPS: 0.26dBic typ. GLONASS: 1.25dBic typ.	
6	Impedance	50 Ohms	
7	Frequency Temperature Coefficient (τf)	0 ± 20ppm / °C	-40°C to +85°C
8	Operating Temperature -40°C to +85°C		

**Changes in user groundplane and environment will offset centre frequency

3. Electrical Specifications

3.1 Return Loss, SWR, Impedance, measured on the test fixture

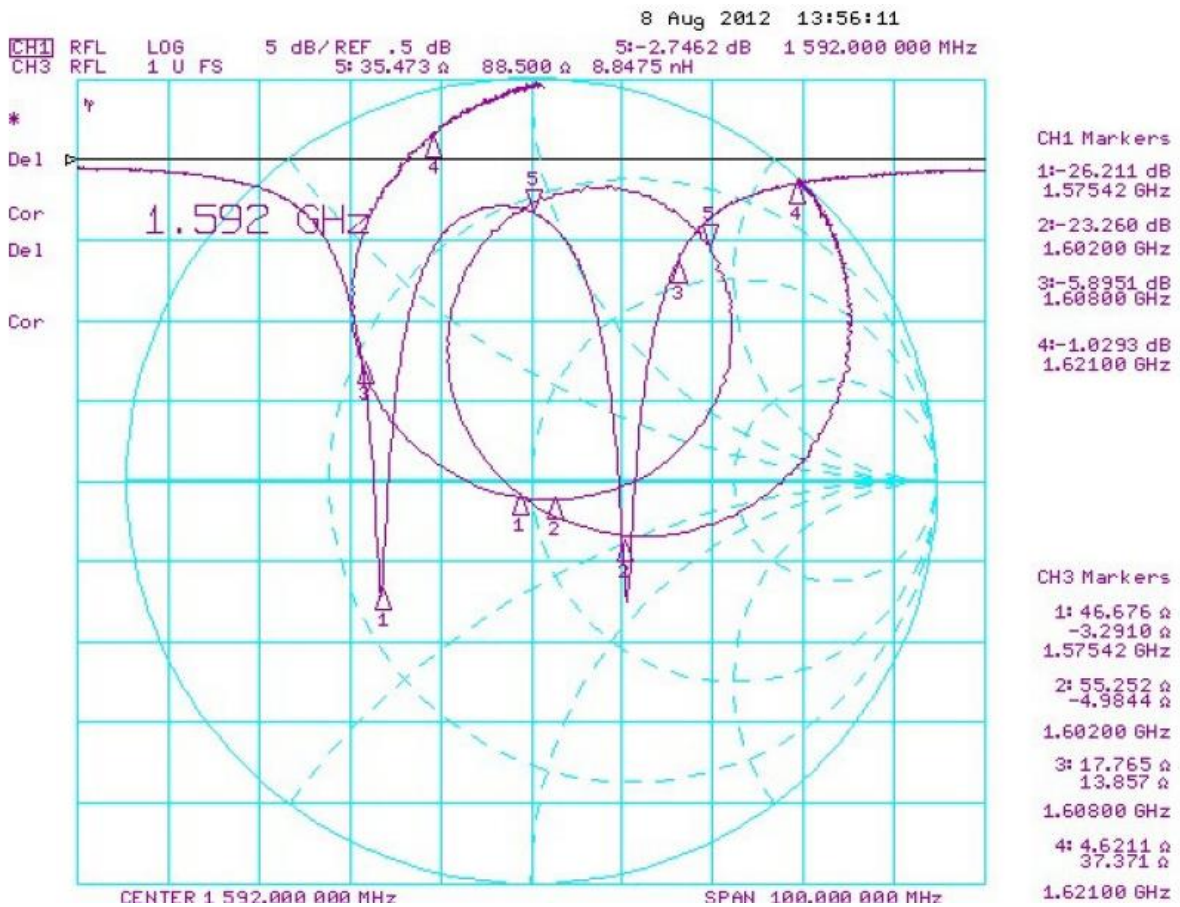

4. Radiation Patterns

4.1 1575MHz

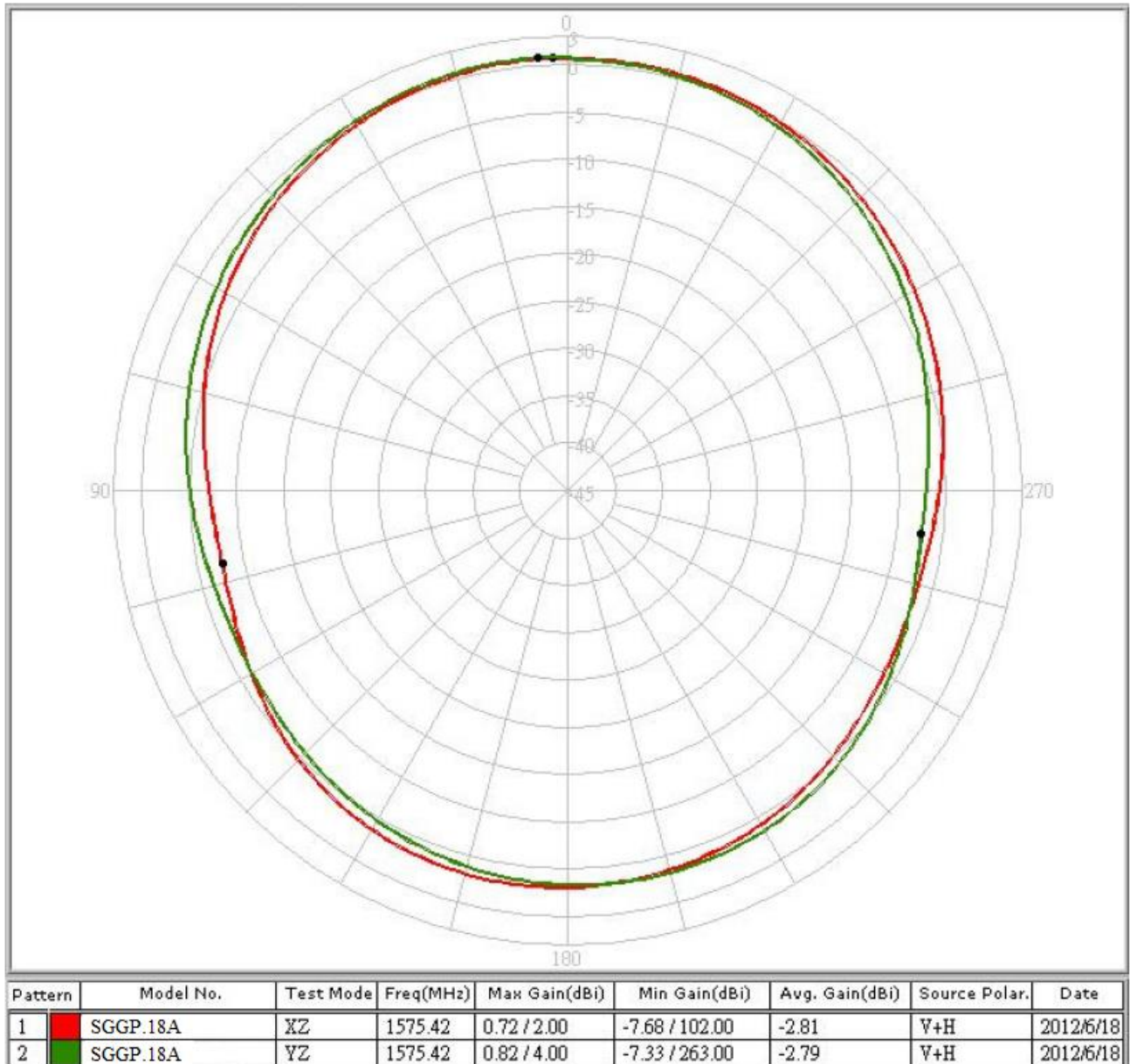

1575.4 MHz XZ+YZ-Plane

4.2 1602MHz

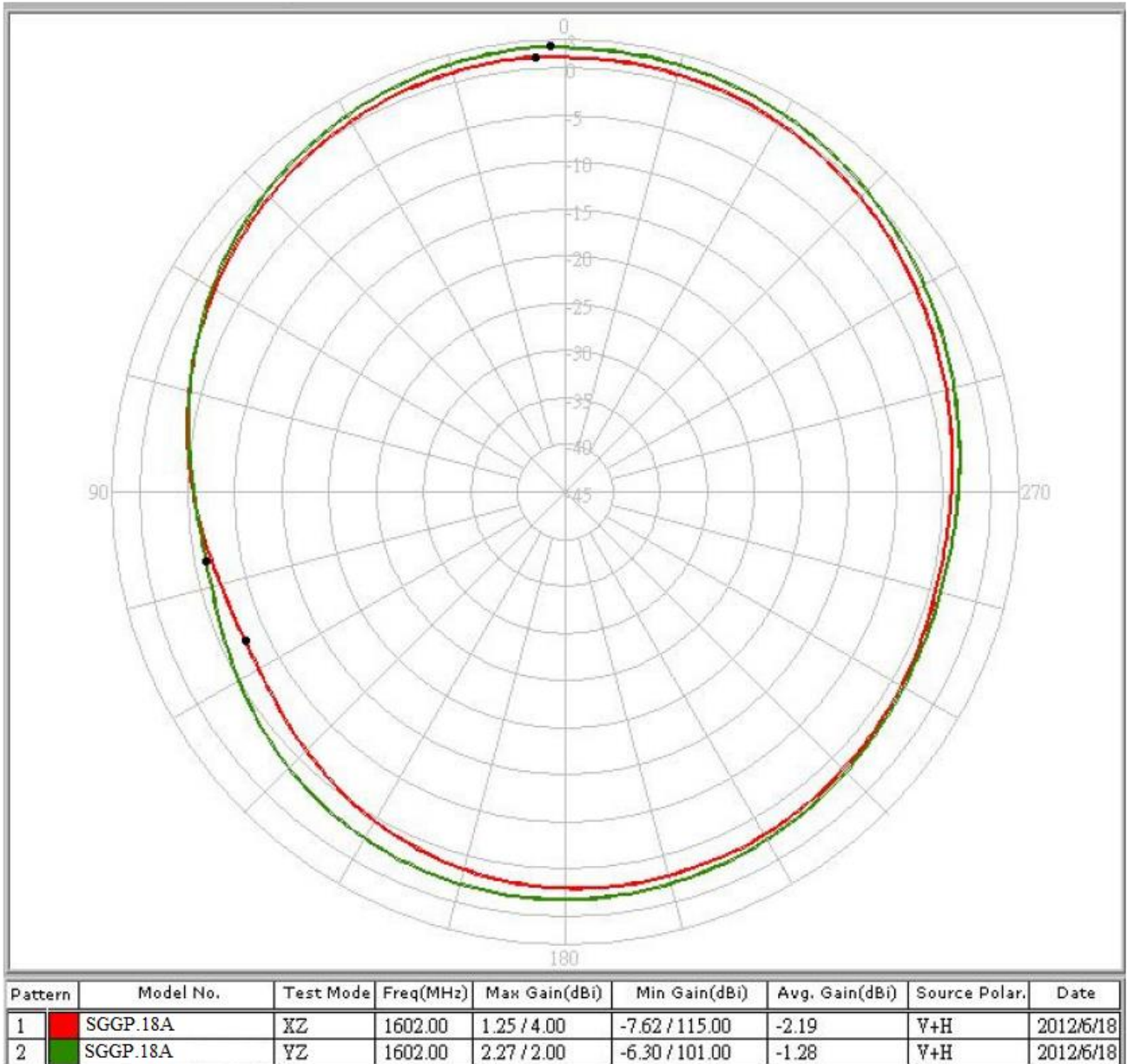

1602.0 MHz XZ+YZ-Plane

5. Mechanical Specifications

5.1 Antenna Dimensions and Drawing

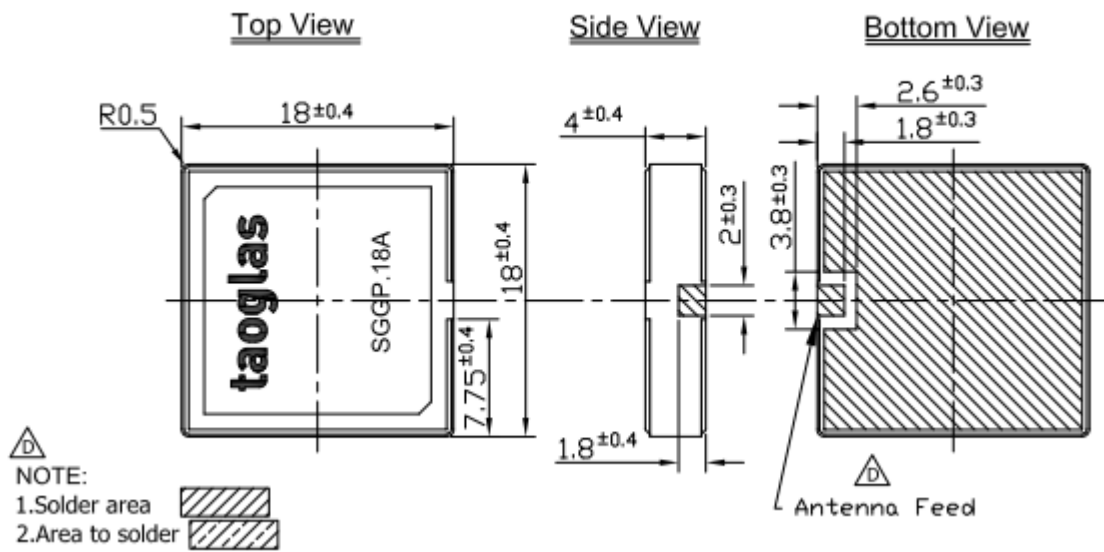

Contact Taoglas Engineering for Footprint Information at support@taoglas.com

5.2 Test Jig and Dimension – SGGP.18A

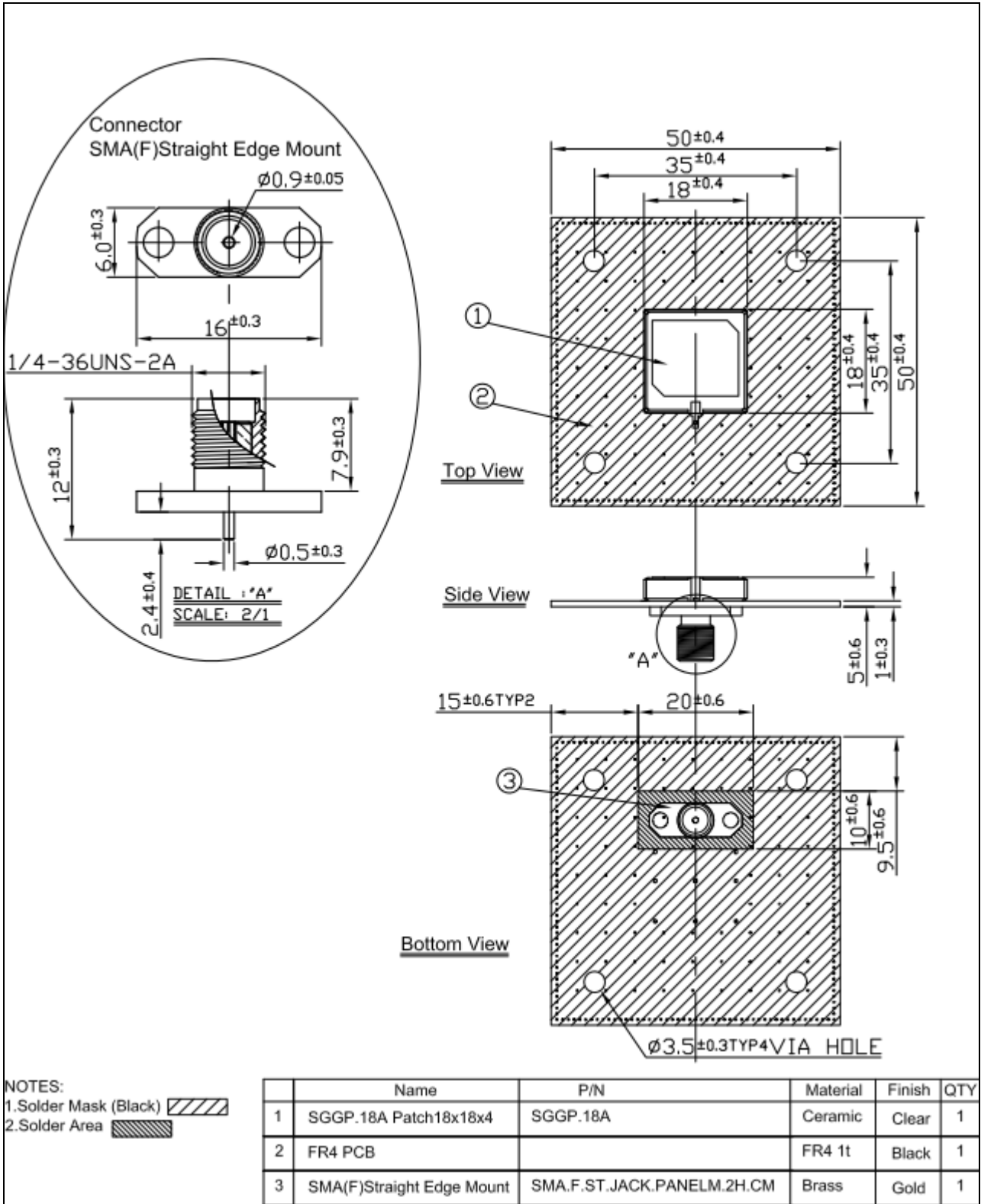

5.3 SGGPD.18A

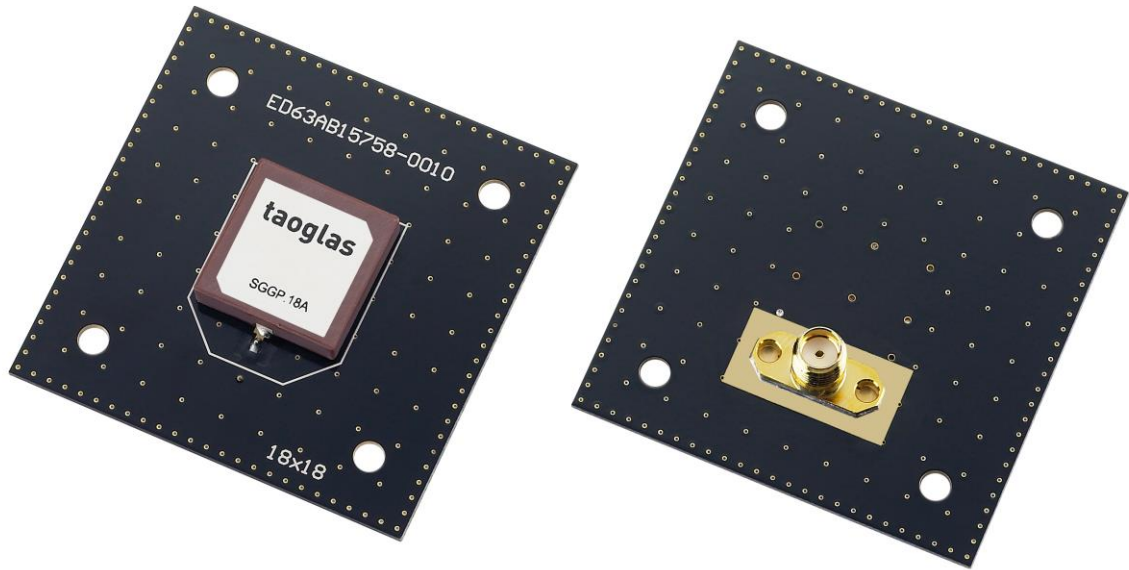

6. Antenna Recommended Soldering Conditions

6.1 Flux, Solder

- Use rosin-based flux. Don't use highly acidic flux with halide content exceeding 0.2wt%(chlorine conversion value).
- Use Sn solder.

6.2 Reflow soldering conditions

- Pre-heating should be in such a way that the temperature difference between solder and product surface is limited to 150°C max. Cooling into solvent after soldering also should be in such a way that temperature difference is limited to 100°C max. Unwrought pre-heating may cause cracks on the product, resulting in the deterioration of products quality.

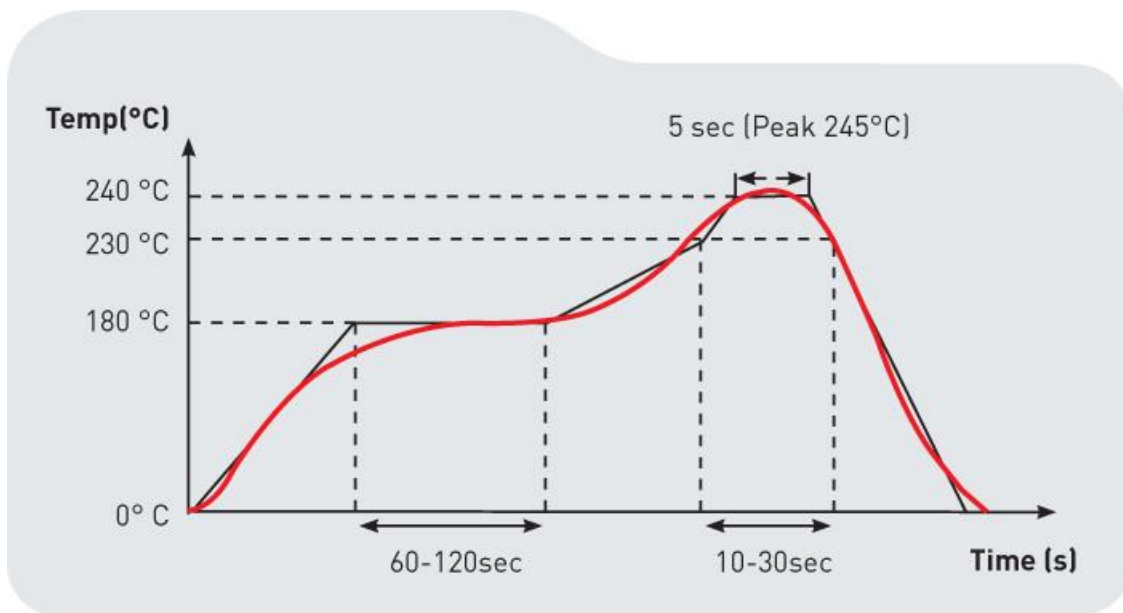

6.3 Reworking with soldering iron

- The following conditions must be strictly followed when using a soldering iron.

Pre-heating	150°C, 1 min
Tip temperature	290°C max
Soldering iron output	30w max
Soldering time	3 second max

7. Packaging

200 pcs/Reel/Inner Carton
 5 Reels in an outer carton

