

## Features & Benefits

- Meets IEC 60603-7-71 standard for Category 7a performance up to 1000 MHz
- Meets IEC 60603-7-7 standard for Category 7 performance up to 600 MHz
- Performance capability up to 3GHz
- Meets the industry standard mechanical interface as defined by IEC 61076-3-110
- Interface compatible with the Nexans' GG45 connectors
- Right angle PCB jack available for Category 7a patch panel designs and high speed active equipment applications
- Uses data transmission pair isolation techniques to achieve high frequency performance
- Plug design includes a built-in strain relief boot as well as an anti-snap feature for plug tab protection

The ARJ45<sup>®</sup> is Bel Stewart's family of connectors for Category 7 and Category 7a premise wiring systems deployed in 10GBase-T Ethernet and higher speed data transmission environments. This connector family consists of a cable-mounted plug and a single-port, PCB-mounted jack designed to meet Category 7a performance standards up to 1000 MHz as defined by the IEC60603-7-71. Additionally, the ARJ45<sup>®</sup> can be used as a high speed connector replacement for closed loop applications currently using less economical connector types.



Bel Stewart's ARJ45<sup>®</sup> connector systems provide a competitive advantage in that they are built on the proven reliability of standard RJ45 interface mechanics which have been enhanced to support increased Category 7a data speeds. In addition, the ARJ45<sup>®</sup> connectors are interface-compatible with the Nexans' GG45 connector system. This makes the ARJ45<sup>®</sup> / GG45 connector system a proven intermatable connector solution for Category 7 and Category 7a that is commercially available today from two independent manufacturing sources.

ARJ45 <sup>®</sup> Jack	
Part Number	Description
SS-77100-004	Single port, horizontal, and shielded
ARJ45 <sup>®</sup> Cable Assemblies	
Part Number	Description
CA77-010M0-2	10 meter cable assembly
CA77-007M0-2	7 meter cable assembly
CA77-005M0-2	5 meter cable assembly
CA77-003M0-2	3 meter cable assembly
CA77-002M0-2	2 meter cable assembly
CA77-001M0-2	1 meter cable assembly

# ARJ45<sup>®</sup> Category 7a Connectors



## Typical Mechanical Dimensions of ARJ45<sup>®</sup> PCB Jacks

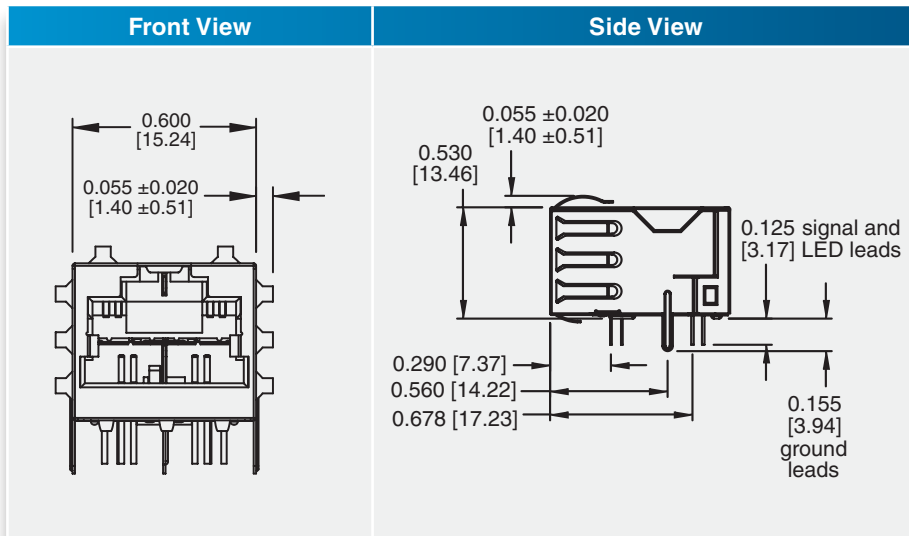

## ARJ45<sup>®</sup> Category 7a Application Performance Data

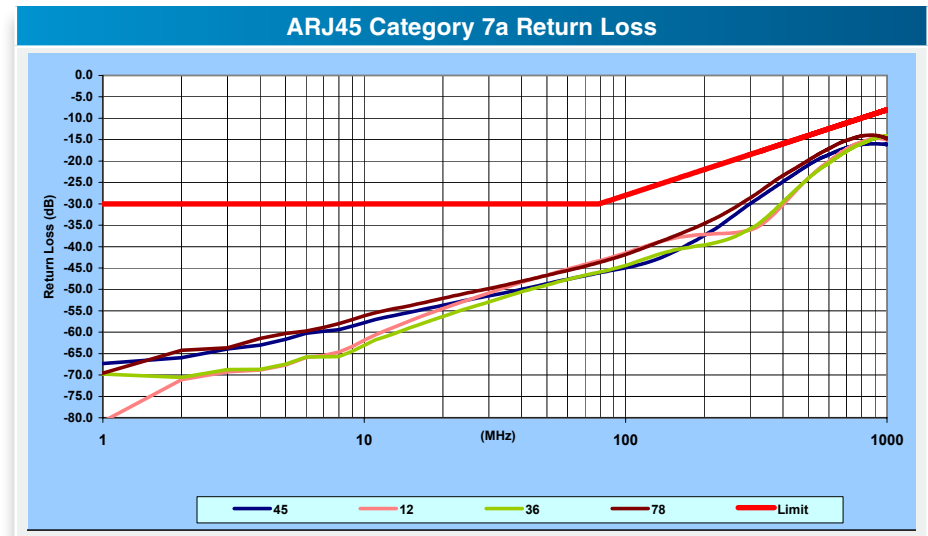

## PCB Recommended Hole Layout

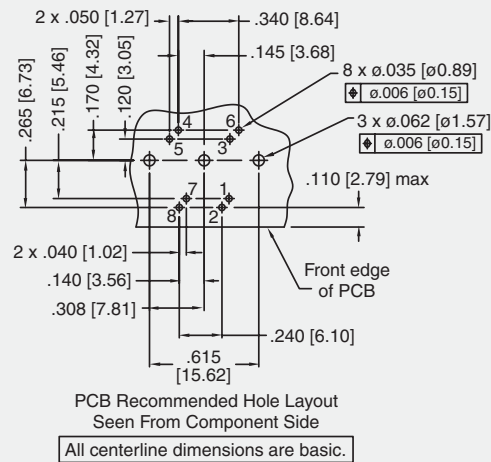

## ARJ45 Category 7a Mated NEXT

