



# L6221A L6221AD L6221N

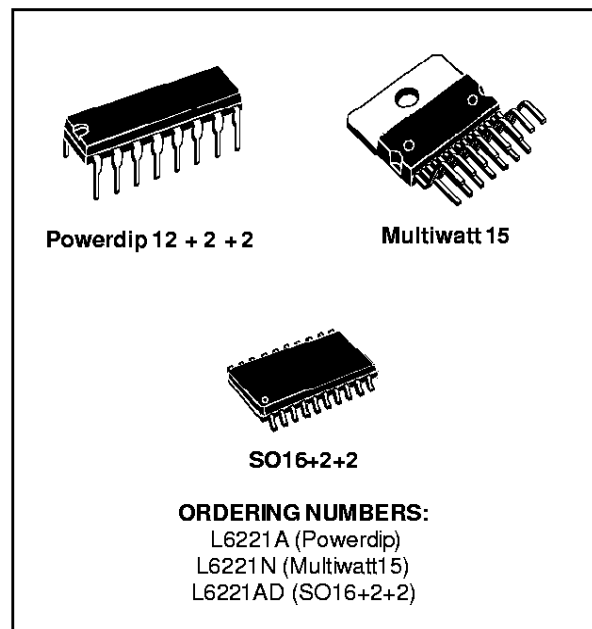
## QUAD DARLINGTON SWITCH

- FOUR NON INVERTING INPUTS WITH ENABLE
- OUTPUT VOLTAGE UP TO 50 V
- OUTPUT CURRENT UP TO 1.8 A
- VERY LOW SATURATION VOLTAGE
- TTL COMPATIBLE INPUTS
- INTEGRAL FAST RECIRCULATION DIODES

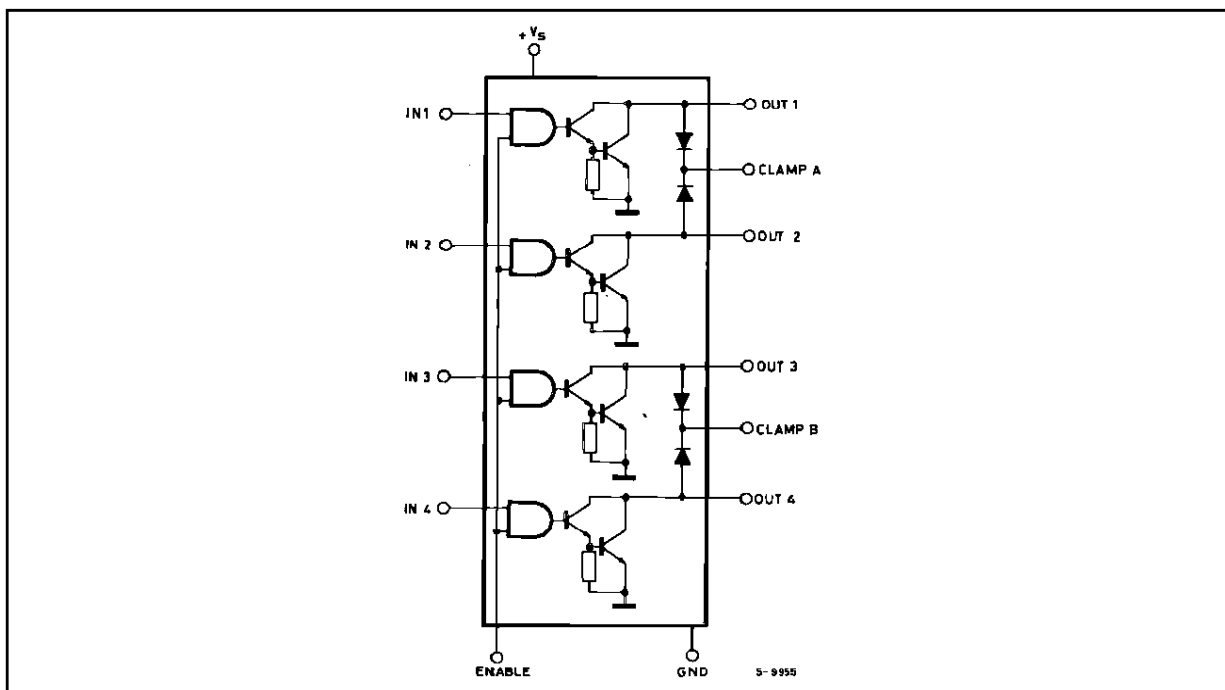
### DESCRIPTION

The L6221 monolithic quad darlington switch is designed for high current, high voltage switching applications. Each of the four switches is controlled by a logic input and all four are controlled by a common enable input. All inputs are TTL-compatible for direct connection to logic circuits.

Each switch consists of an open-collector darlington transistor plus a fast diode for switching applications with inductive device loads. The emitters of the four switches are commoned. Any number of inputs and outputs of the same device may be paralleled.



### BLOCK DIAGRAM

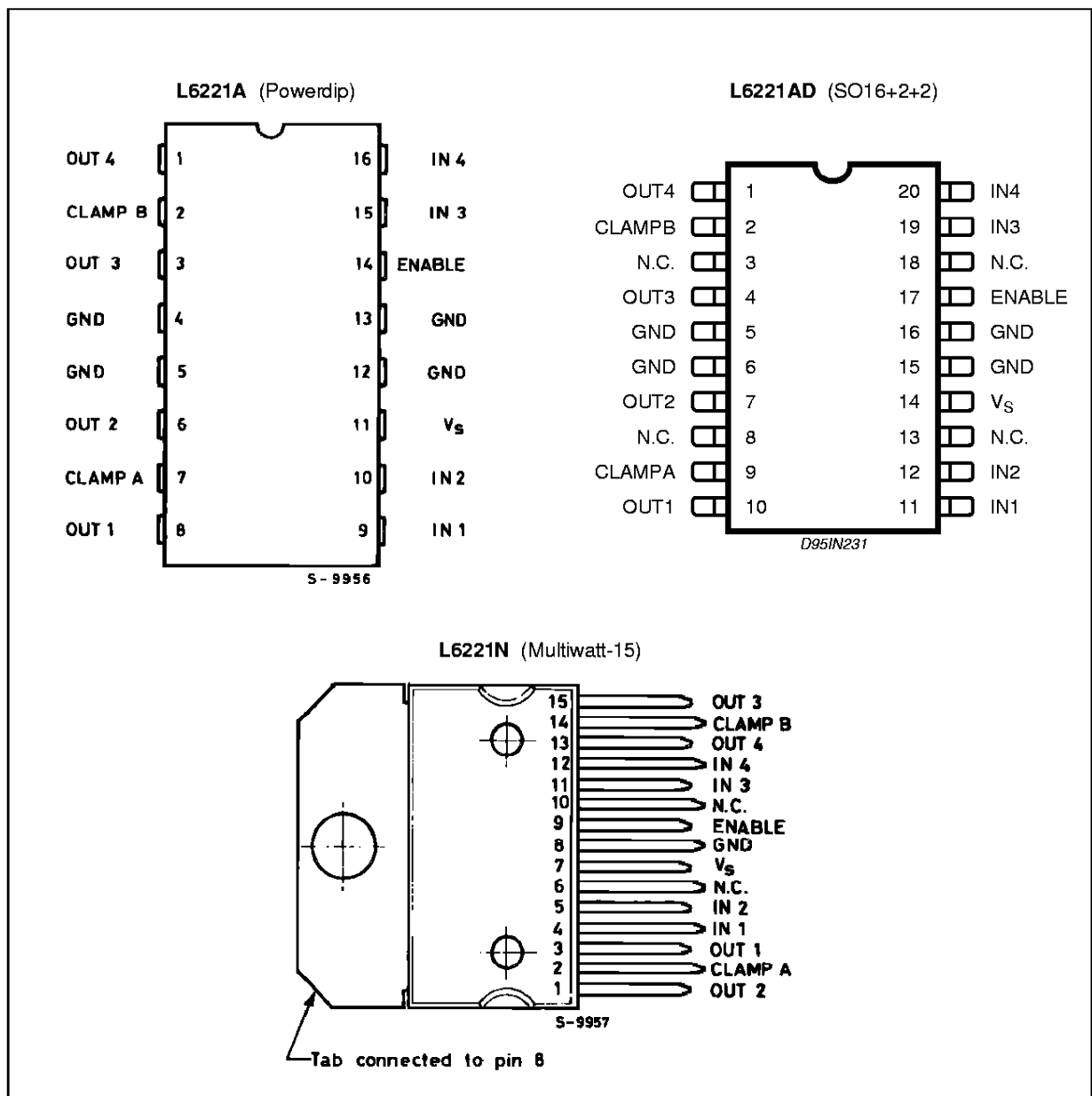


# L6221A - L6221AD - L6221N

## THERMAL DATA

Symbol	Parameter		SO20	Powerdip	Multiwatt15	Unit
$R_{th\ j-pins}$	Thermal Resistance Junction-pins	Max.	17	14	–	°C/W
$R_{th\ j-case}$	Thermal Resistance Junction-case	Max.	–	–	3	°C/W
$R_{th\ j-amb}$	Thermal Resistance Junction-ambient	Max.	80	80	35	°C/W

## PIN CONNECTIONS (top views)



## ABSOLUTE MAXIMUM RATINGS

Symbol	Parameter	Value	Unit	
$V_o$	Output Voltage	50	V	
$V_s$	Logic Supply Voltage	7	V	
$V_{IN}, V_{EN}$	Input Voltage, Enable Voltage	$V_s$		
$I_C$	Continuous Collector Current (for each channel)	1.8	A	
$I_C$	Collector Peak Current (repetitive, duty cycle = 10 % $t_{on} = 5$ ms)	2.5	A	
$I_C$	Collector Peak Current (non repetitive, $t = 10$ $\mu$ s)	3.2	A	
$T_{op}$	Operating Temperature Range (junction)	- 40 to + 150	$^{\circ}$ C	
$T_{sig}$	Storage Temperature Range	- 55 to + 150	$^{\circ}$ C	
$I_{sub}$	Output Substrate Current	350	mA	
$P_{tot}$	Total Power Dissipation	at $T_{pins} = 90$ $^{\circ}$ C (powerdip)	4.3	W
		at $T_{case} = 90$ $^{\circ}$ C (multiwatt)	20	W
		at $T_{case} = 90$ $^{\circ}$ C (SO20)	3.5	W
		at $T_{amb} = 70$ $^{\circ}$ C (powerdip)	1	W
		at $T_{amb} = 70$ $^{\circ}$ C (multiwatt)	2.3	W
		at $T_{amb} = 70$ $^{\circ}$ C (SO20)	1	W

## TRUTH TABLE

Enable	Input	Power Out
H	H	ON
H	L	OFF
L	X	OFF

For each input: H = High level  
L = Low level

## PIN FUNCTIONS (see block diagram)

Name	Function
IN 1	Input to Driver 1
IN 2	Input to Driver 2
OUT 1	Output of Driver 1
OUT 2	Output of Driver 2
CLAMP A	Diode Clamp to Driver 1 and Driver 2
IN 3	Input to Driver 3
IN 4	Input to Driver 4
OUT 3	Output of Driver 3
OUT 4	Output of Driver 4
CLAMP B	Diode Clamp to Driver 3 and Driver 4
ENABLE	Enable Input to All Drivers
$V_s$	Logic Supply Voltage
GND	Common Ground

**ELECTRICAL CHARACTERISTICS**

 Refer to the test circuit to Fig. 1 to Fig. 9 ( $V_S = 5V$ ,  $T_{amb} = 25^{\circ}C$  unless otherwise specified)

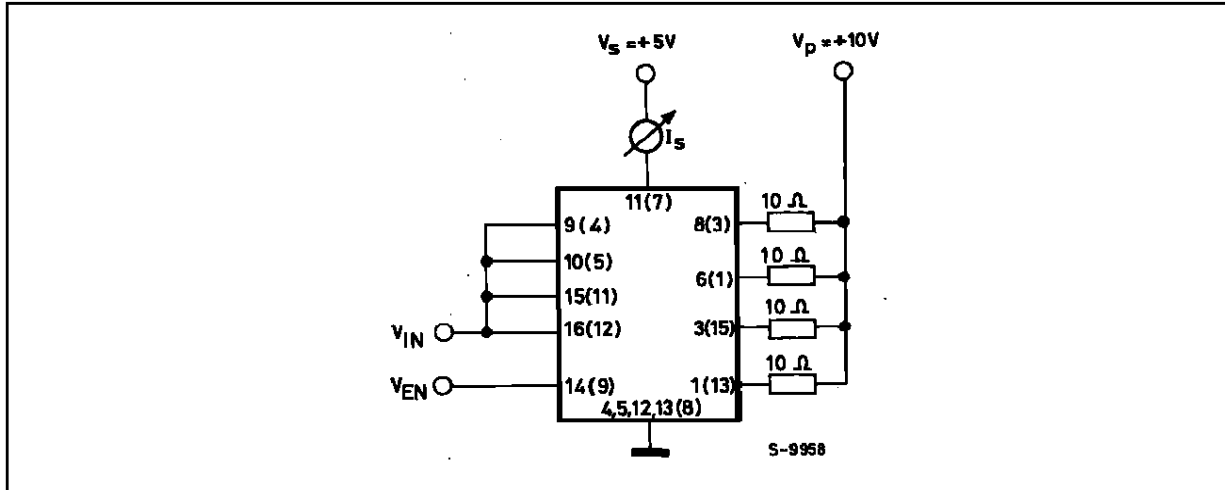
Symbol	Parameter	Test Conditions	Min .	Typ .	Max .	Unit
$V_S$	Logic Supply Voltage		4.5		5.5	V
$I_S$	Logic Supply Current	All Outputs ON, $I_C = 0.7A$ All Outputs OFF			20 20	mA mA
$V_{CE(sus)}$	Output Sustaining Voltage	$V_{IN} = V_{INL}$ , $V_{EN} = V_{ENH}$ $I_C = 100\text{ mA}$	46			V
$I_{CEX}$	Output Leakage Current	$V_{CE} = 50V$ $V_{IN} = V_{INL}$ , $V_{EN} = V_{ENH}$			1	mA
$V_{CE(sat)}$	Collector Emitter Saturation Voltage (one input on ; all others inputs off.)	$V_S = 4.5V$ $V_{IN} = V_{INH}$ , $V_{EN} = V_{ENH}$ $I_C = 0.6A$ $I_C = 1A$ $I_C = 1.8A$			1 1.2 1.6	V
$V_{INL}$ , $V_{ENL}$	Input Low Voltage				0.8	V
$I_{INL}$ , $I_{ENL}$	Input Low Current	$V_{IN} = V_{INL}$ , $V_{EN} = V_{ENL}$			- 100	$\mu A$
$V_{INH}$ , $V_{ENH}$	Input High Voltage		2.0			V
$I_{INH}$ , $I_{ENH}$	Input High Current	$V_{IN} = V_{INH}$ , $V_{EN} = V_{ENH}$			$\pm 10$	$\mu A$
$I_R$	Clamp Diode Leakage Current	$V_R = 50\text{ V}$ , $V_{EN} = V_{ENH}$ $V_{IN} = V_{INL}$			100	$\mu A$
$V_F$	Clamp Diode Forward Voltage	$I_F = 1A$ $I_F = 1.8A$			1.6 2.0	V V
$t_d(\text{on})$	Turn on Delay Time	$V_p = 5V$ , $R_L = 10\Omega$			2	$\mu s$
$t_d(\text{off})$	Turn off Delay Time	$V_p = 5V$ , $R_L = 10\Omega$			5	$\mu s$
$\Delta I_S$	Logic Supply Current Variation	$V_{IN} = 5V$ , $V_{EN} = 5V$ $I_{out} = -300\text{ mA}$ for Each Channel			120	m A

TEST CIRCUITS

(X) = Referred to Multiwatt package

X = Referred to Powerdip package

Figure 1 : Logic supply current.



Set  $V_{IN} = 4.5V$ ,  $V_{EN} = 0.8V$ , or  $V_{IN} = 0.8V$ ,  $V_{EN} = 4.5V$ , for  $I_S$  (all outputs off)

Set  $V_{IN} = 2V$ ,  $V_{EN} = 2V$ , for  $I_S$  (all outputs on)

Figure 2 : Output Sustaining Voltage.

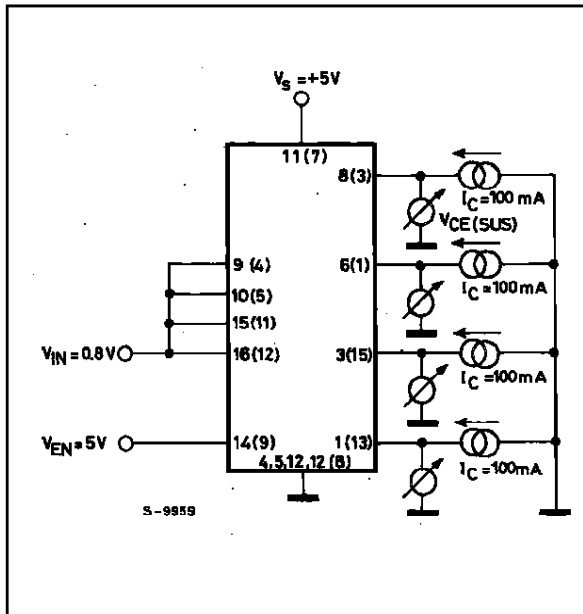


Figure 3 : Output Leakage Current.

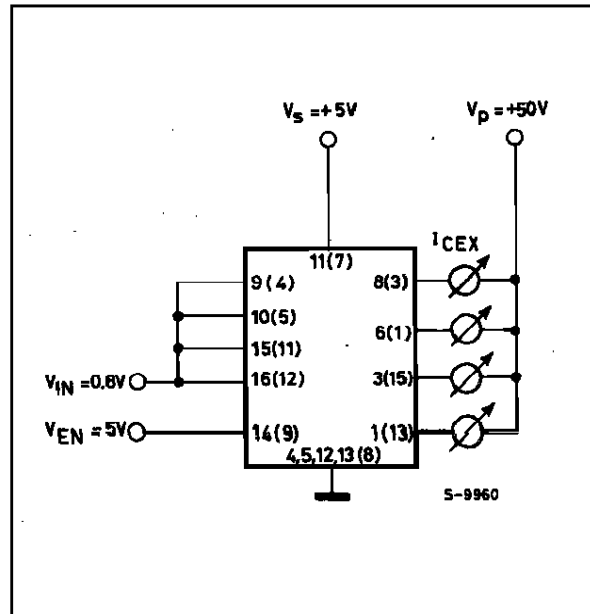


Figure 4 : Collector-emitter Saturation Voltage

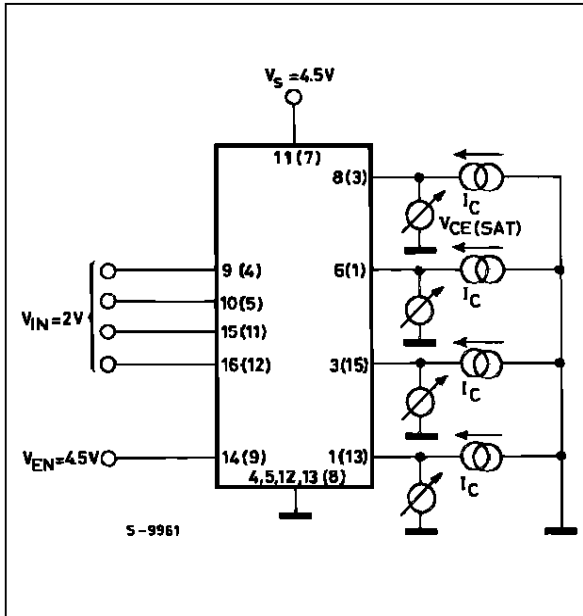


Figure 6 : Clamp Diode Leakage Current.

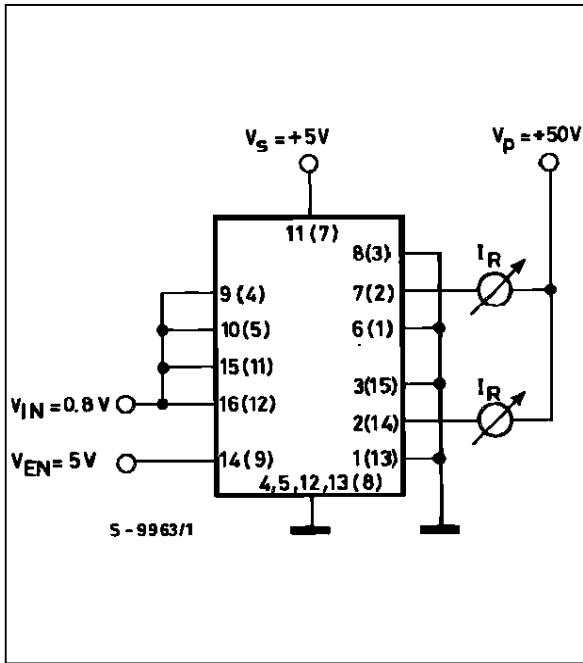
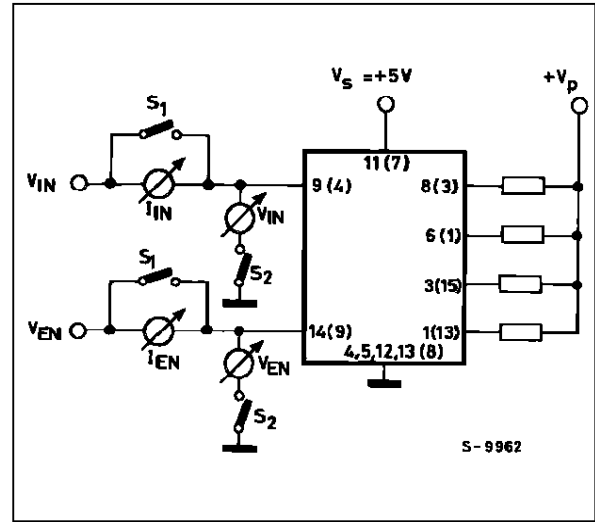


Figure 5 : Logic Input Characteristics



S<sub>et</sub> S<sub>1</sub>, S<sub>2</sub> open, V<sub>IN</sub>, V<sub>EN</sub> = 0.8V for I<sub>IN</sub> L, I<sub>EN</sub> L  
 S<sub>et</sub> S<sub>1</sub>, S<sub>2</sub> open, V<sub>IN</sub>, V<sub>EN</sub> = 2V for I<sub>IN</sub> H, I<sub>EN</sub> H  
 S<sub>et</sub> S<sub>1</sub>, S<sub>2</sub> close, V<sub>IN</sub>, V<sub>EN</sub> = 0.8V for V<sub>IN</sub> L, V<sub>EN</sub> L  
 S<sub>et</sub> S<sub>1</sub>, S<sub>2</sub> close, V<sub>IN</sub>, V<sub>EN</sub> = 2V for V<sub>IN</sub> H, V<sub>EN</sub> H

Figure 7 : Clamp Diode Forward Voltage.

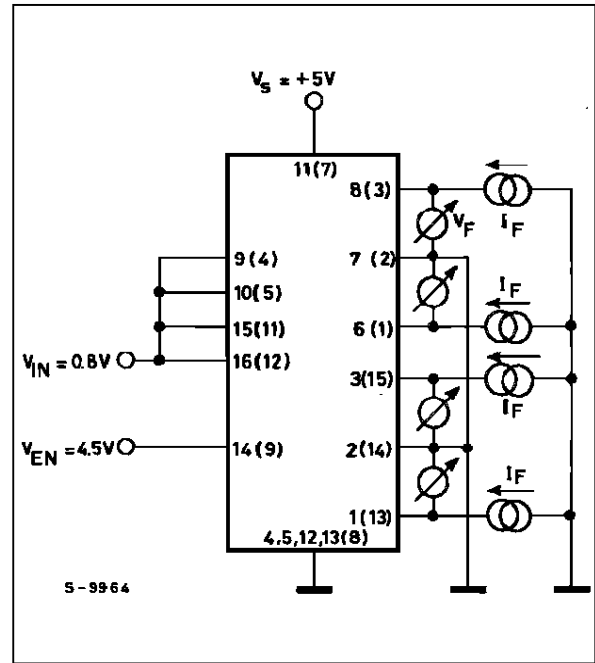


Figure 8 : Switching Times Test Circuit.

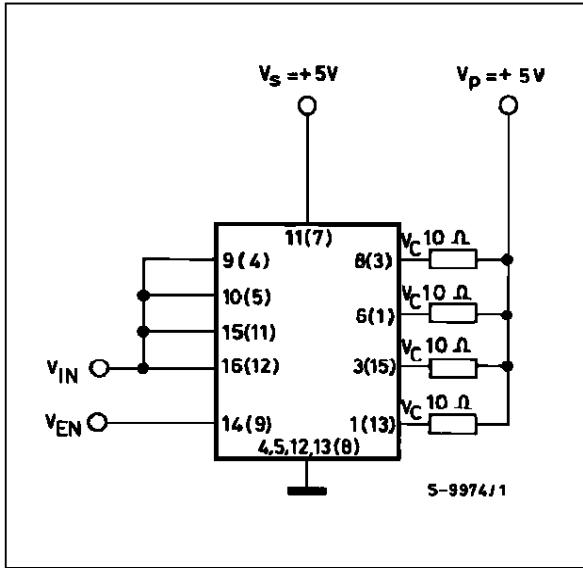


Figure 9 : Switching Times Waveforms.

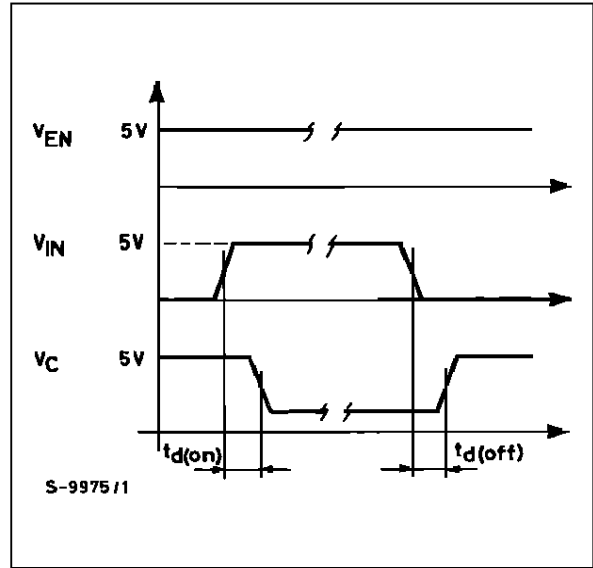


Figure 10 : Allowed Peak Collector Current versus Duty Cycle for 1, 2, 3 or 4 Contemporary Working Outputs (L6221A)

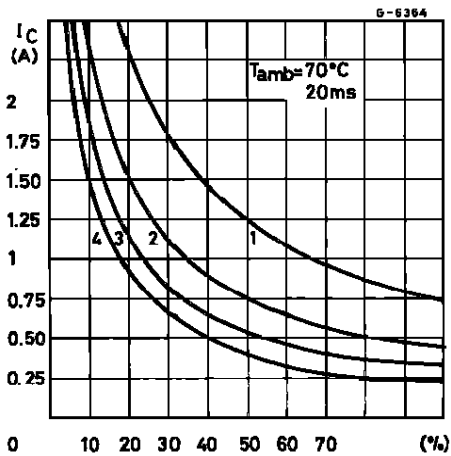


Figure 11 : Allowed Peak Collector Current versus Duty Cycle for 1, 2, 3 or 4 Contemporary Working Outputs (L6221N)

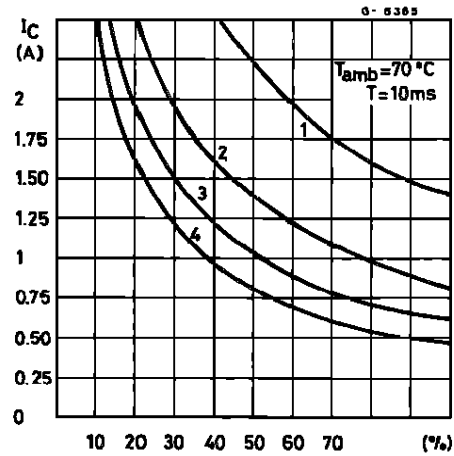


Figure 12 : Collector Saturation Voltage versus Collector Current

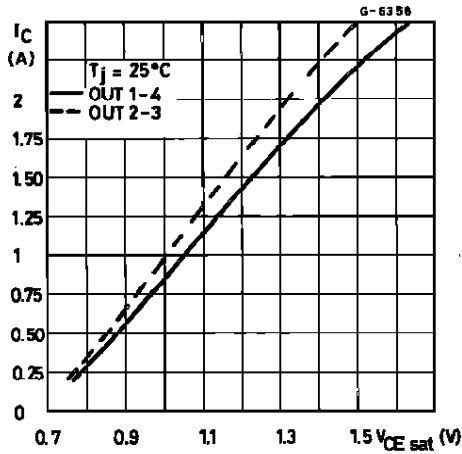


Figure 13 : Free-wheeling Diode Forward Voltage versus Diode Current

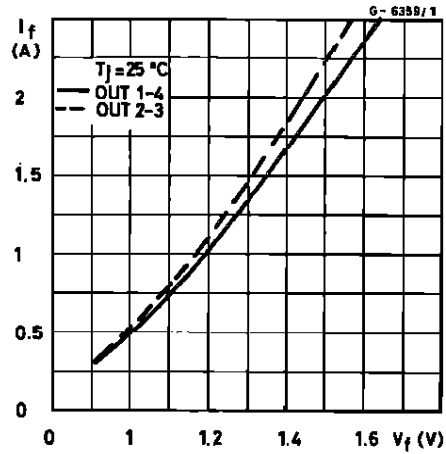


Figure 14 : Collector Saturation Voltage versus Junction Temperature at IC = 1A

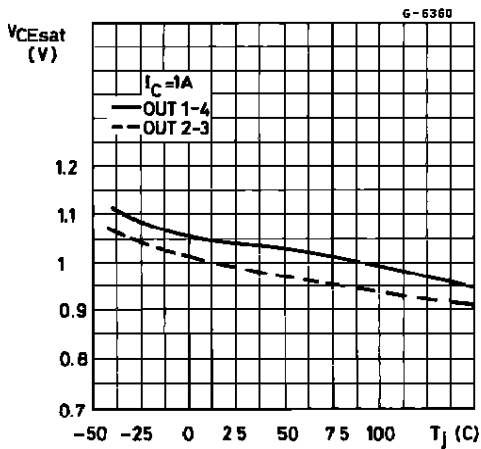


Figure 15 : Free-wheeling Diode Forward Voltage versus Junction Temperature at IF = 1A

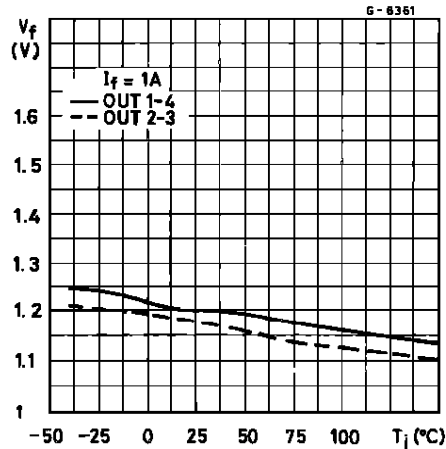


Figure 16 : Saturation Voltage vs. Junction Temperature at IC = 1.8A

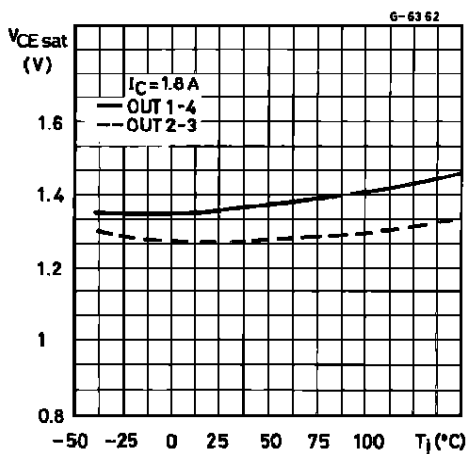
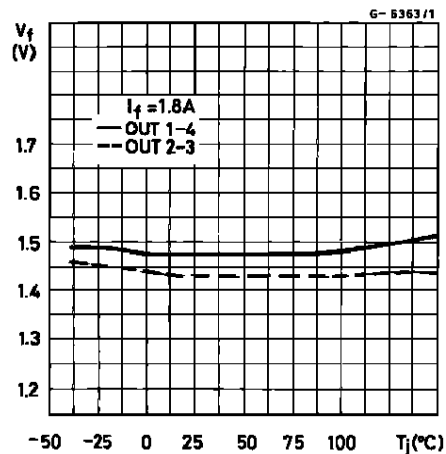


Figure 17 : Free-wheeling Diode Forward Voltage versus Junction Temperature at IF = 1.8A





**APPLICATION INFORMATION**

When inductive loads are driven by L6221A/N, a zenerdiode in series with the integral free-wheeling diodes increases the voltage across which energy stored in the load is discharged and therefore speeds the current decay (fig. 18).

For reliability it is suggested that the zener is chosen so that  $V_p + V_z < 35 V$ .

The reasons for this are two fold :

- 1) The zener voltage changes in temperature and current.
- 2) The instantaneous power must be limited to avoid the reverse second breakdown.

Figure 18.

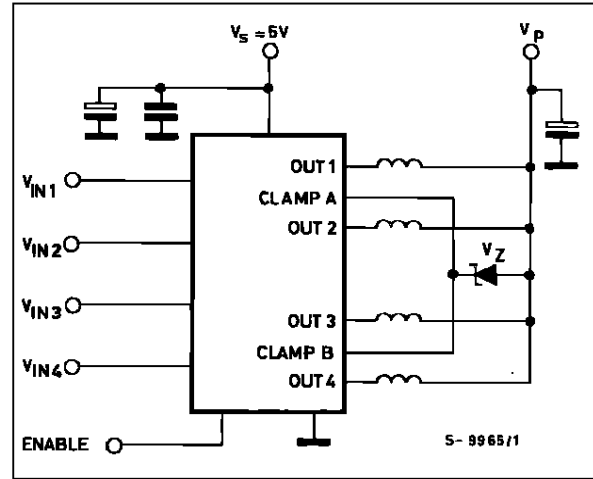
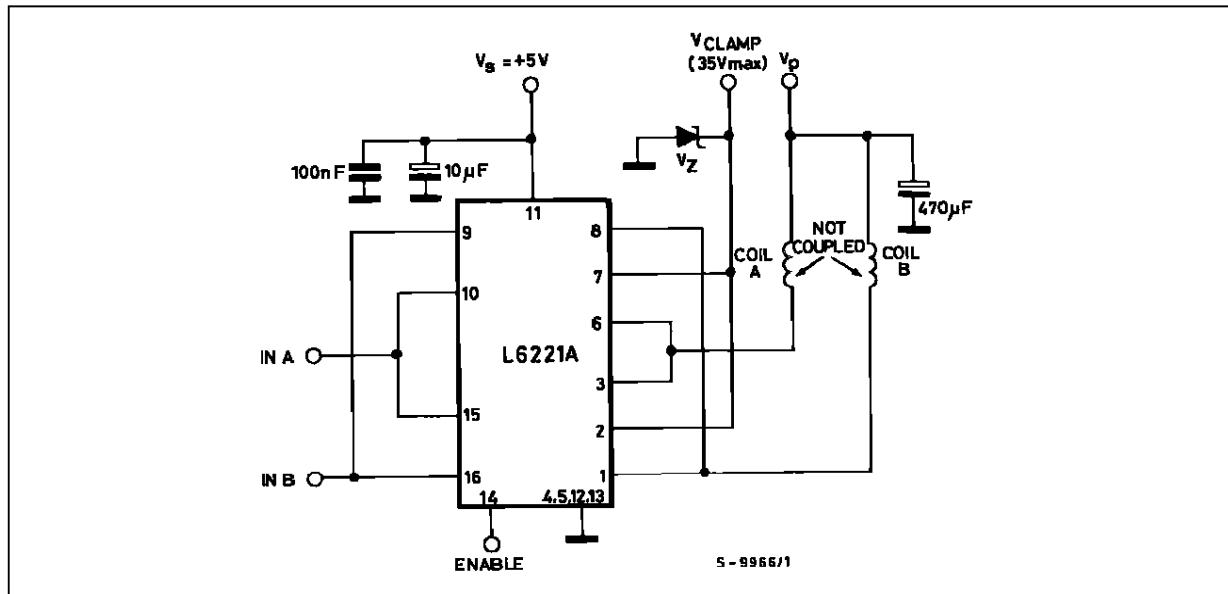


Figure 19 : Driver for Solenoids up to 3A.

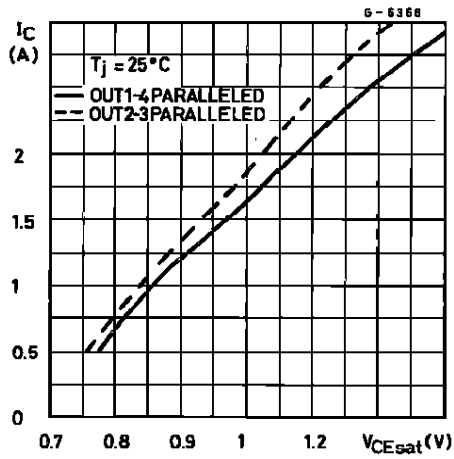


Some care must be taken to ensure that the collectors are placed close together to avoid different current partitioning at turn-off.

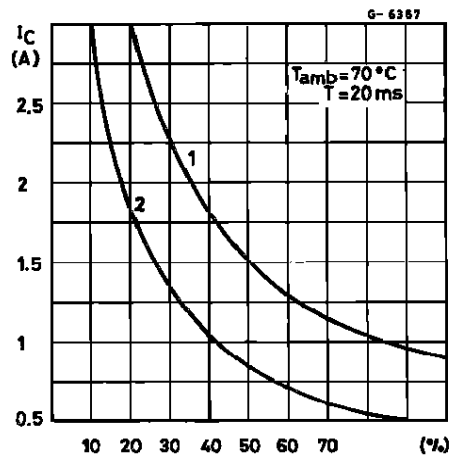
We suggest to put in parallel channel 1 and 4 and channel 2 and 3 as shown in figure 19 for the similar

electrical characteristics of the logic section (turn-on and turn-off delay time) and the power stages (collector saturation voltage, free-wheeling diode forward voltage).

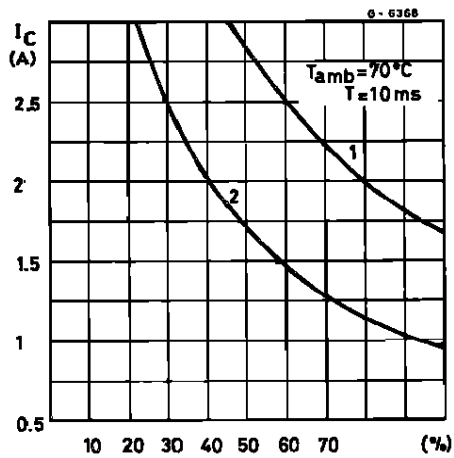
**Figure 20 :** Saturation Voltage versus Collector Current



**Figure 21 :** Peak Collector Current versus Duty Cycle for 1 or 2 Paralleled Outputs Driven (L6221A)



**Figure 22 :** Peak Collector Current versus Duty Cycle for 1 or 2 Paralleled Outputs Driven (L6221N)



**MOUNTING INSTRUCTION**

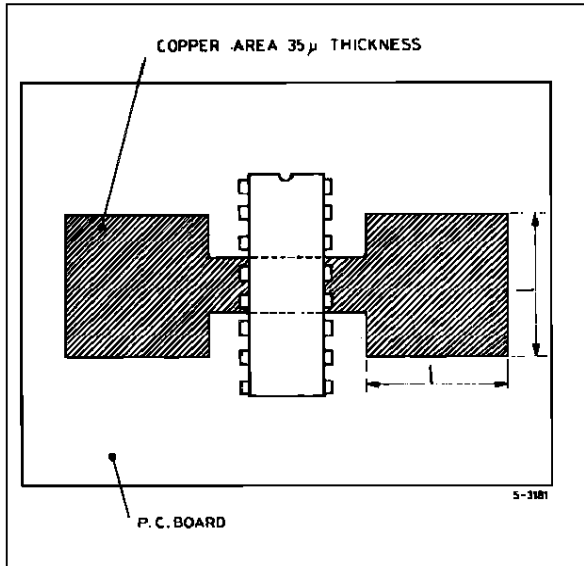
The  $R_{th j-amb}$  of the L6221A can be reduced by soldering the GND pins to a suitable copper area of the printed circuit board (Fig. 23) or to an external heatsink (Fig. 24).

The diagram of figure 25 shows the maximum dissippable power  $P_{tot}$  and the  $R_{th j-amb}$  as a function of the side "α" of two equal square copper areas hav-

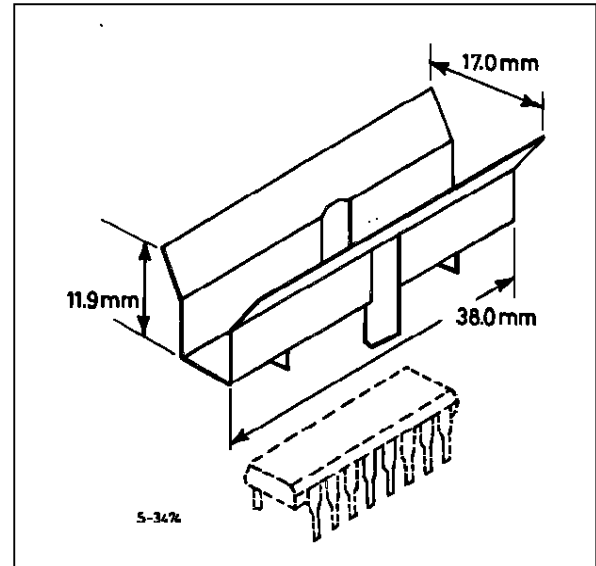
ing a thickness of  $35\mu$  (1.4 mils). During soldering the pins temperature must not exceed  $260\text{ }^{\circ}\text{C}$  and the soldering time must not be longer than 12 seconds.

The external heatsink or printed circuit copper area must be connected to electrical ground.

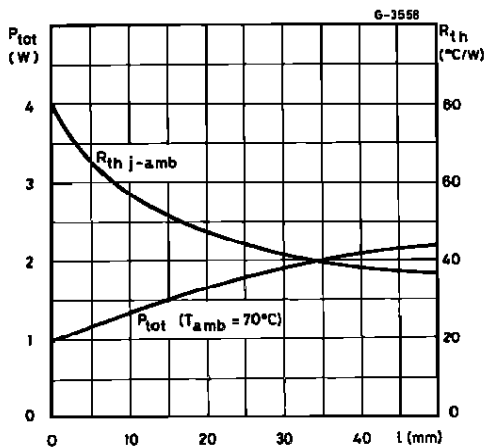
**Figure 23 :** Example of P.C. Board Copper Area Which is Used as Heatsink



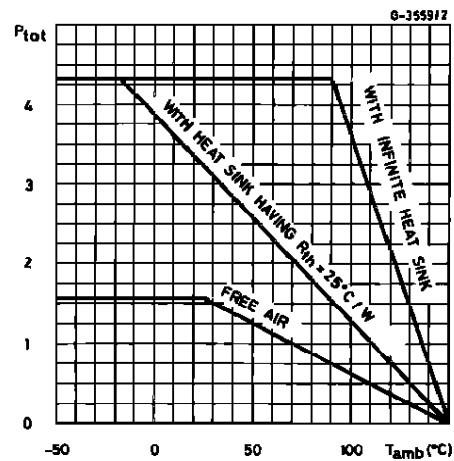
**Figure 24 :** External Heatsink Mounting Example



**Figure 25 :** Maximum Dissippable Power and Junction to Ambient Thermal Resistance versus Side "α"

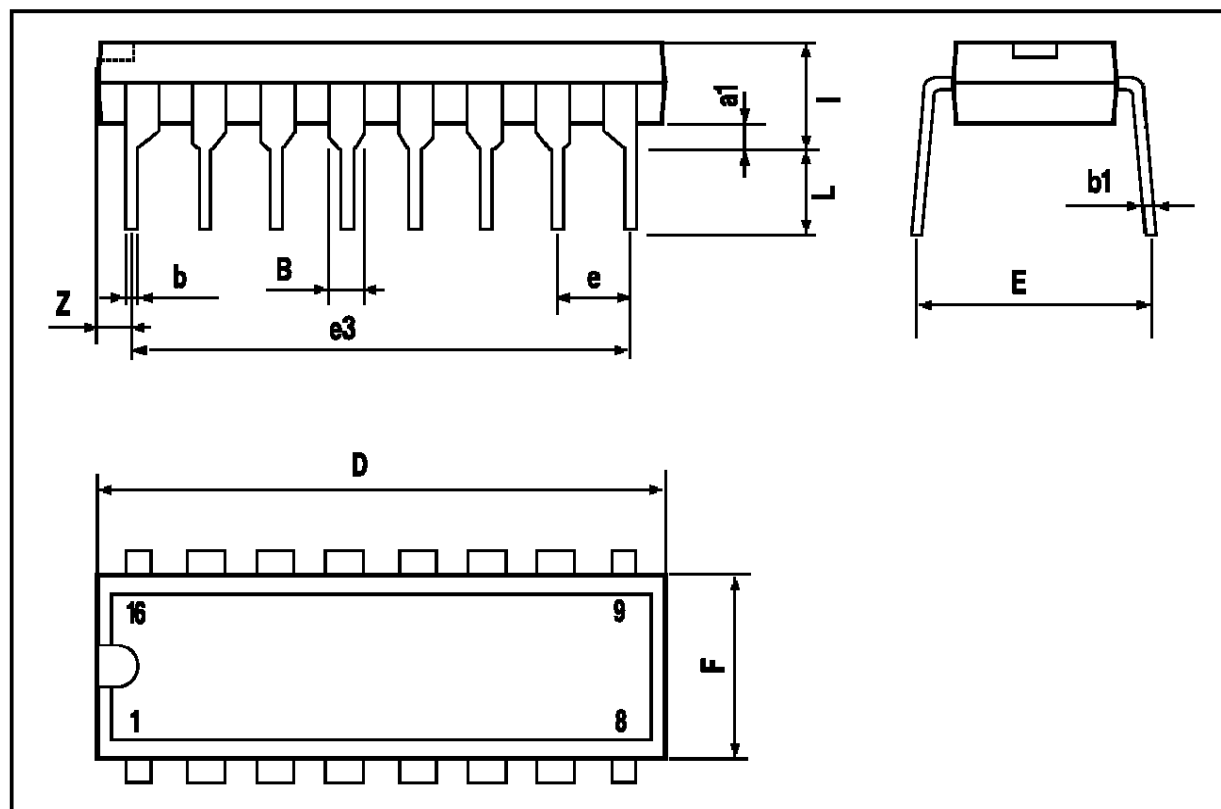


**Figure 26 :** Maximum Allowable Power Dissipation versus Ambient Temperature



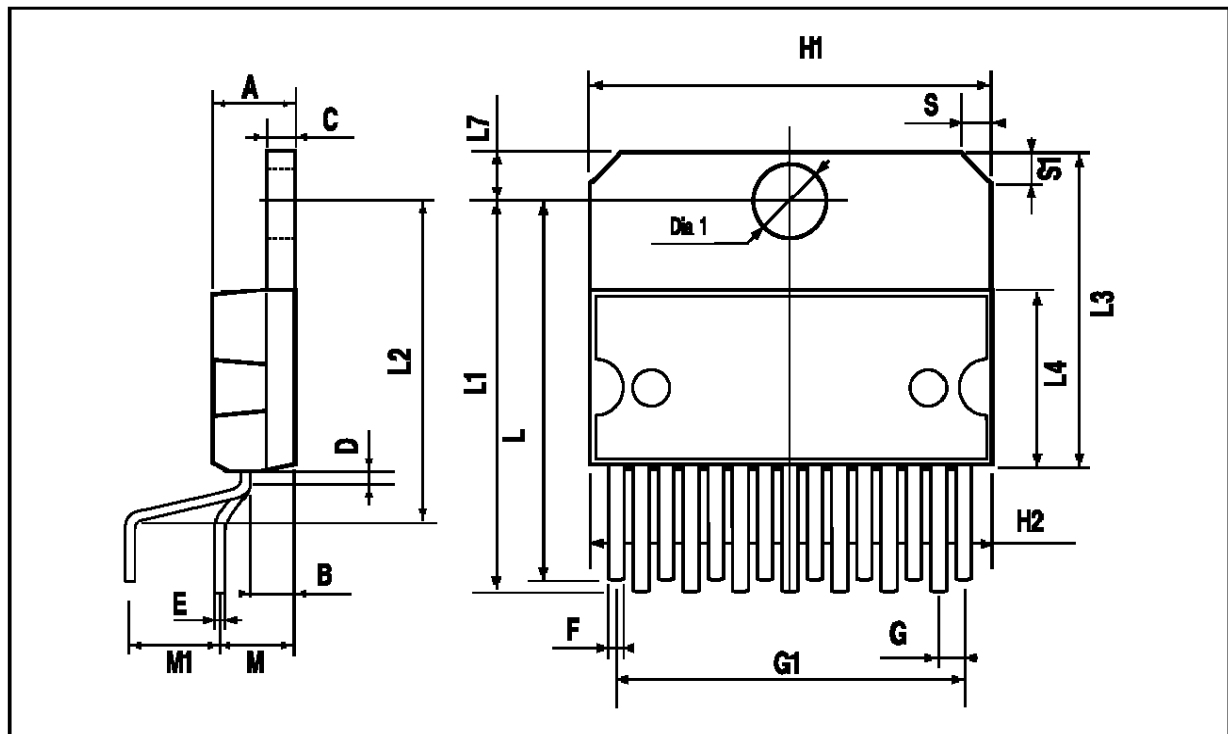
POWERDIP 16 PACKAGE MECHANICAL DATA

DIM.	mm			inch		
	MIN.	TYP.	MAX.	MIN.	TYP.	MAX.
a1	0.51			0.020		
B	0.85		1.40	0.033		0.055
b		0.50			0.020	
b1	0.38		0.50	0.015		0.020
D			20.0			0.787
E		8.80			0.346	
e		2.54			0.100	
e3		17.78			0.700	
F			7.10			0.280
I			5.10			0.201
L		3.30			0.130	
Z			1.27			0.050



MULTIWATT 15 PACKAGE MECHANICAL DATA

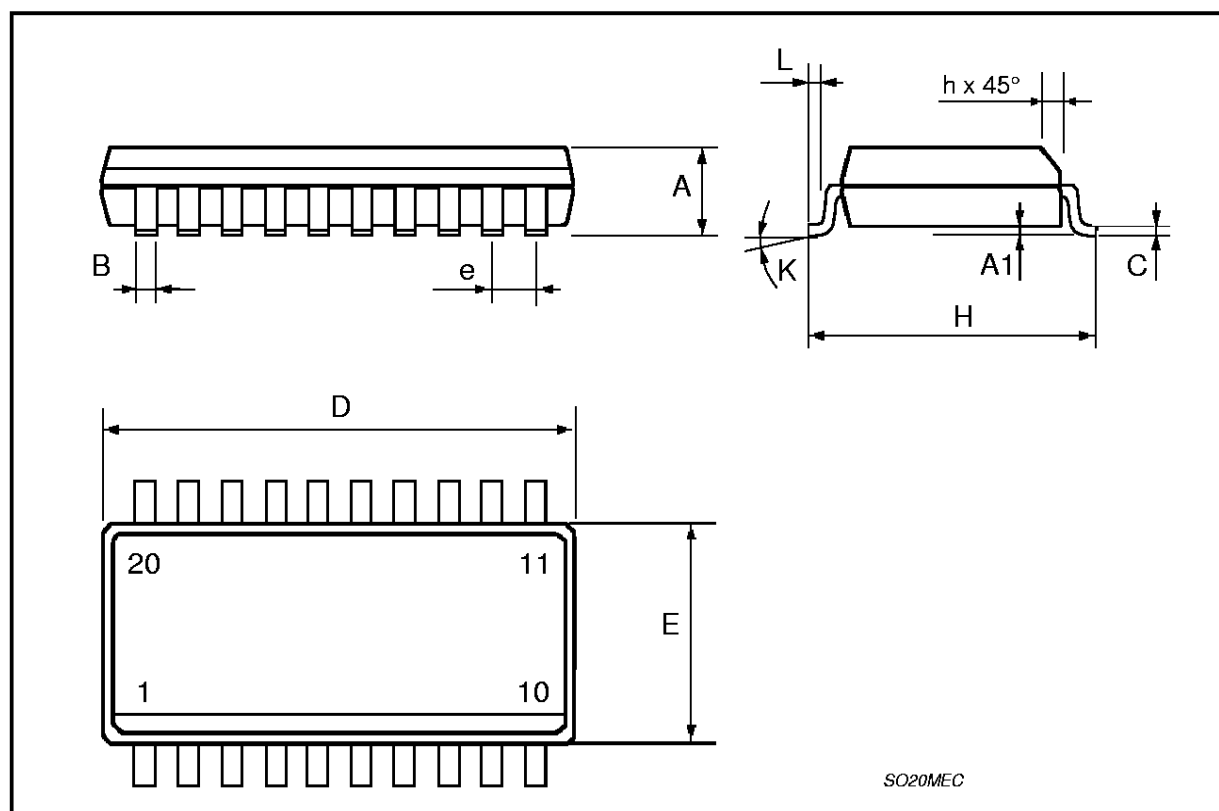
DIM.	mm			inch		
	MIN.	TYP.	MAX.	MIN.	TYP.	MAX.
A			5			0.197
B			2.65			0.104
C			1.6			0.063
D		1			0.039	
E	0.49		0.55	0.019		0.022
F	0.66		0.75	0.026		0.030
G	1.02	1.27	1.52	0.040	0.050	0.060
G1	17.53	17.78	18.03	0.690	0.700	0.710
H1	19.6			0.772		
H2			20.2			0.795
L	21.9	22.2	22.5	0.862	0.874	0.886
L1	21.7	22.1	22.5	0.854	0.870	0.886
L2	17.65		18.1	0.695		0.713
L3	17.25	17.5	17.75	0.679	0.689	0.699
L4	10.3	10.7	10.9	0.406	0.421	0.429
L7	2.65		2.9	0.104		0.114
M	4.25	4.55	4.85	0.167	0.179	0.191
M1	4.63	5.08	5.53	0.182	0.200	0.218
S	1.9		2.6	0.075		0.102
S1	1.9		2.6	0.075		0.102
Dia1	3.65		3.85	0.144		0.152



**L6221A - L6221AD - L6221N**

**SO20 PACKAGE MECHANICAL DATA**

DIM.	mm			inch		
	MIN.	TYP.	MAX.	MIN.	TYP.	MAX.
A	2.35		2.65	0.093		0.104
A1	0.1		0.3	0.004		0.012
B	0.33		0.51	0.013		0.020
C	0.23		0.32	0.009		0.013
D	12.6		13	0.496		0.512
E	7.4		7.6	0.291		0.299
e		1.27			0.050	
H	10		10.65	0.394		0.419
h	0.25		0.75	0.010		0.030
L	0.4		1.27	0.016		0.050
K	0 (min.)8 (max.)					



Information furnished is believed to be accurate and reliable. However, STMicroelectronics assumes no responsibility for the consequences of use of such information nor for any infringement of patents or other rights of third parties which may result from its use. No license is granted by implication or otherwise under any patent or patent rights of STMicroelectronics. Specification mentioned in this publication are subject to change without notice. This publication supersedes and replaces all information previously supplied. STMicroelectronics products are not authorized for use as critical components in life support devices or systems without express written approval of STMicroelectronics.

The ST logo is a registered trademark of STMicroelectronics

© 1998 STMicroelectronics – Printed in Italy – All Rights Reserved

STMicroelectronics GROUP OF COMPANIES

Australia - Brazil - Canada - China - France - Germany - Italy - Japan - Korea - Malaysia - Malta - Mexico - Morocco - The Netherlands - Singapore - Spain - Sweden - Switzerland - Taiwan - Thailand - United Kingdom - U.S.A.