

SPECIFICATION

Part No. : **GP.1575.35.3.A.02**

Specification No : **GP.35A**

Product Name : **3.5mm thick GPS Patch Antenna, 1575MHz**

Features : 35mm*35mm*3.5mm
ROHS Compliant

:



1. Introduction

This 35*35mm ceramic GPS patch antenna is based on smart *XtremeGain*™ technology. It is mounted via pin and double-sided adhesive and has been tuned as optimal solution for the customer device environment.

2. Key Antenna Performance Indicators

Original Patch Specification tested on 50*50mm ground plane

No	Parameter	Specification	Notes
1	Range of Receiving Frequency	1616~1626.5MHz	
2	Center Frequency	1575MHz ± 6MHz	With 50x50mm ground plane
3	Bandwidth	22MHz min	Return Loss ≤ -10 dB
4	VSWR	1.5 max	Center Frequency
5	Gain at Zenith	2.0 dBic typ.	
6	Gain at 10°elevation	1.5dBic typ.	
7	Axial Ratio	3 dB max	
8	Polarization	RHCP	
9	Impedance	50 Ohms	
10	Frequency Temperature Coefficient (Tf)	0 ± 20ppm / °C	-40°C to +85°C
11	Operating Temperature	-40°C to +85°C	

3. Electrical Specification

3.1 Smith Chart

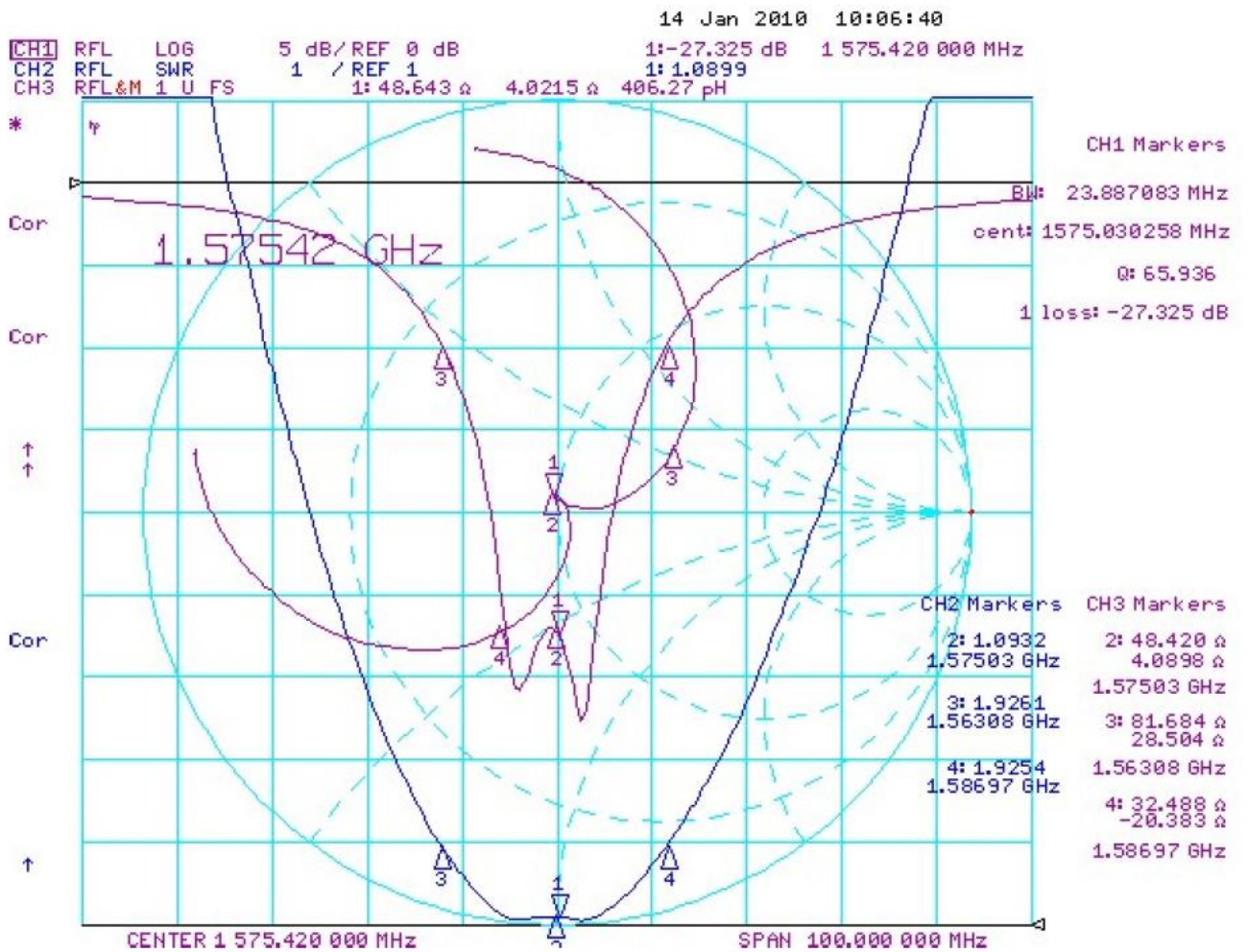

4. 2D Radiation

4.1 XZ Plane Radiation

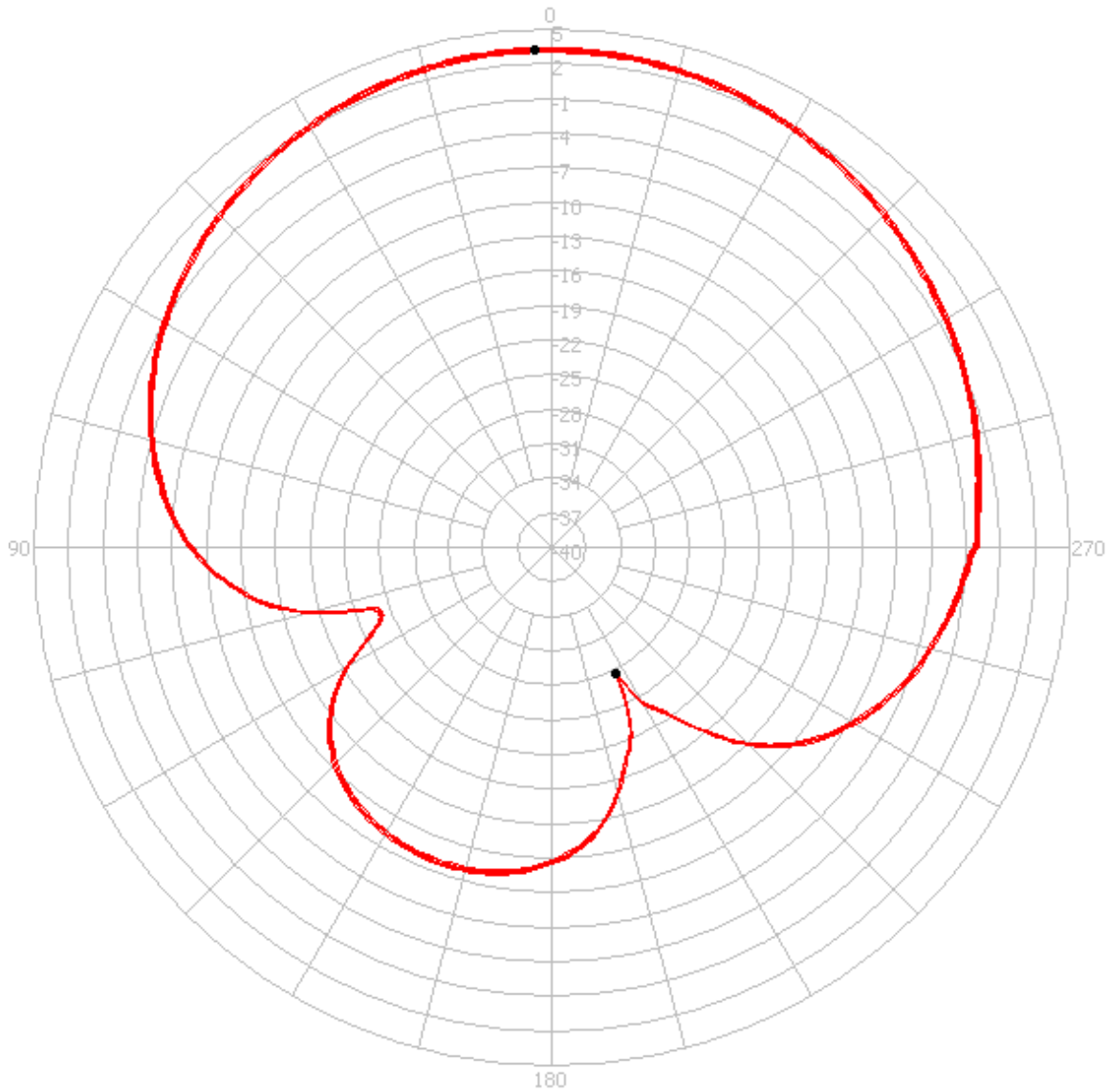

4.2 YZ Plane Radiation

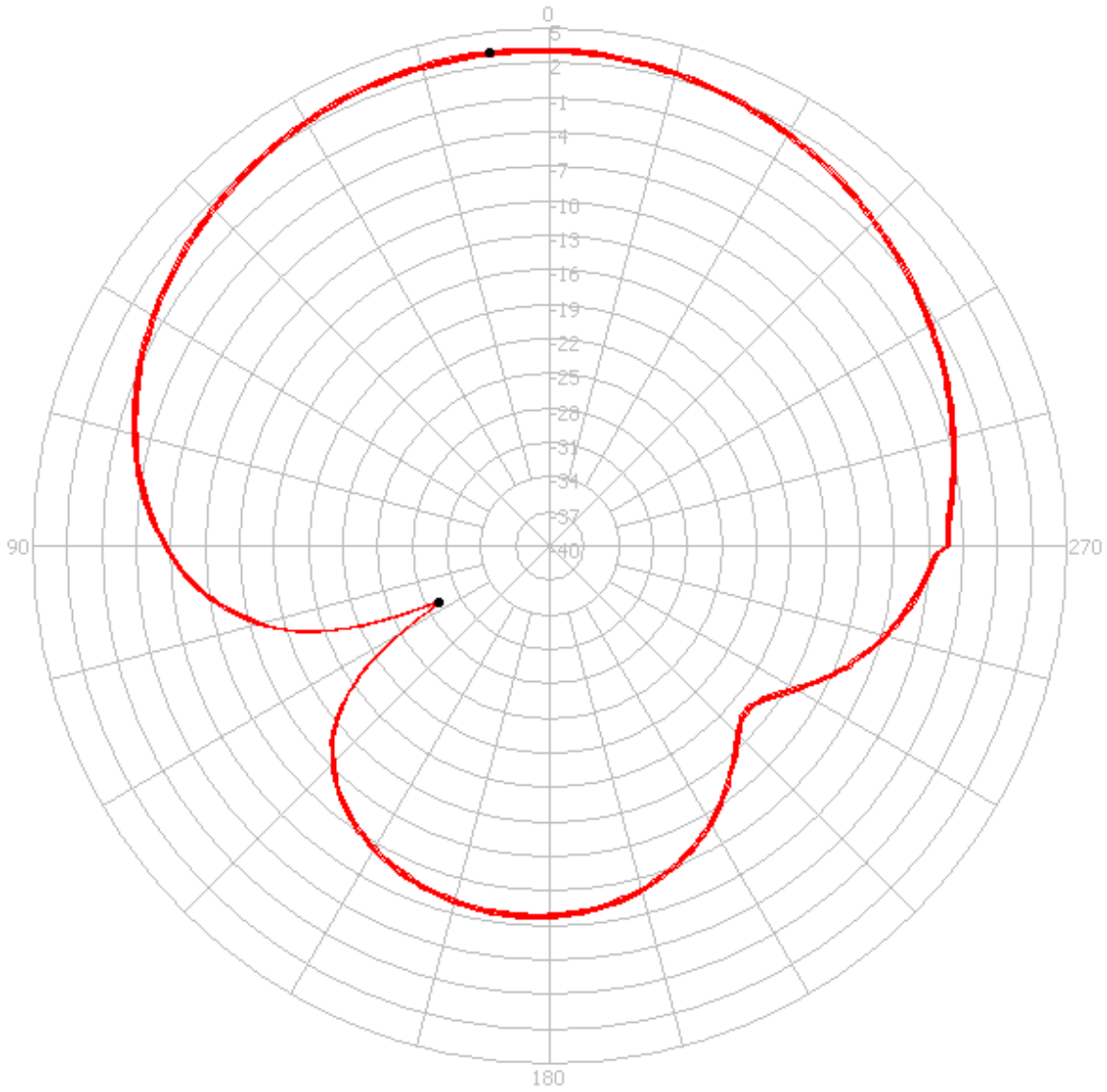

4.3 Axial Ratio

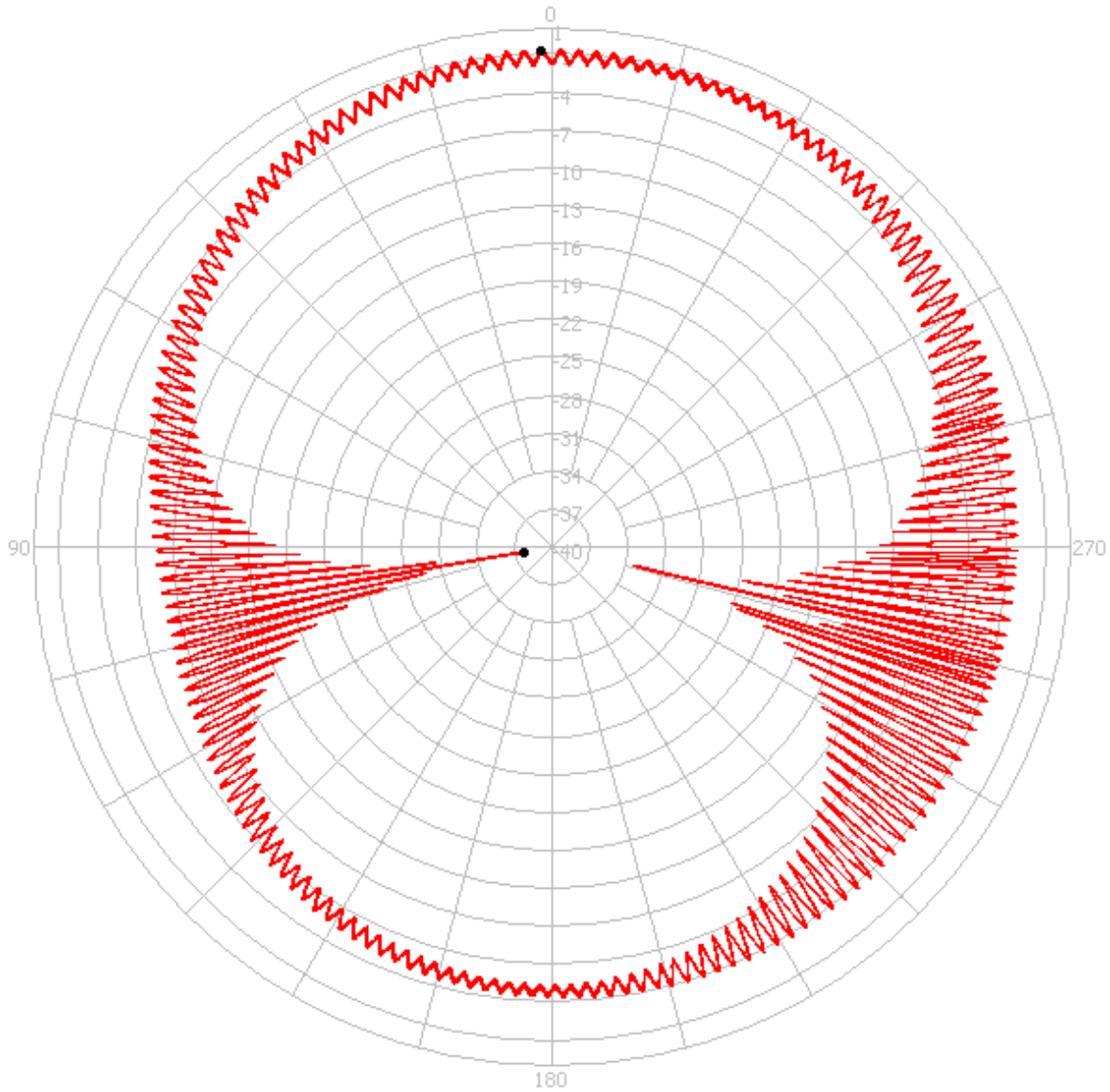

5. Mechanical Drawing

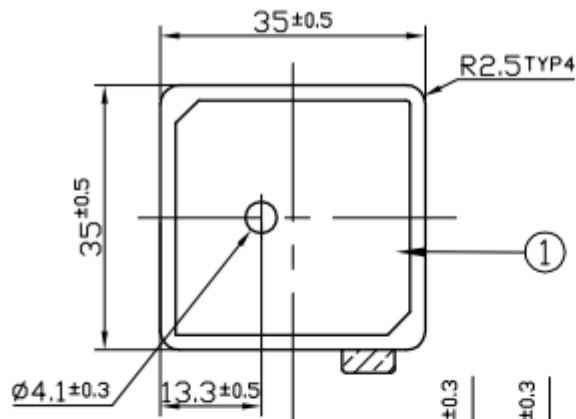

Top View

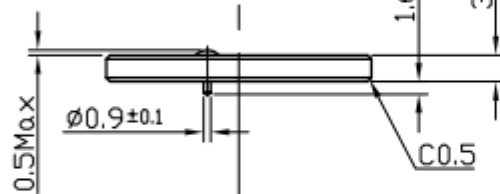

Side View

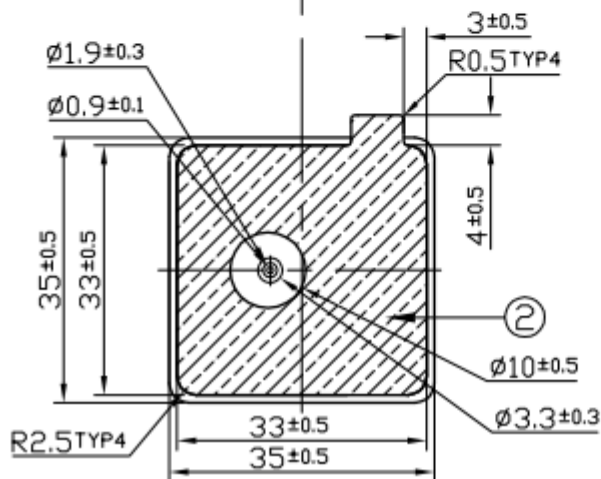

Bottom View

	Name	Material	Finish	QTY	NOTES:
1	GP.35 Patch 35x35x3.5	Ceramic	Clear	1	1.Double sided adhesive area. 
2	Double sided Adhesive	NITTO 5015	White Liner	1	

5.1 Layout Dimensions

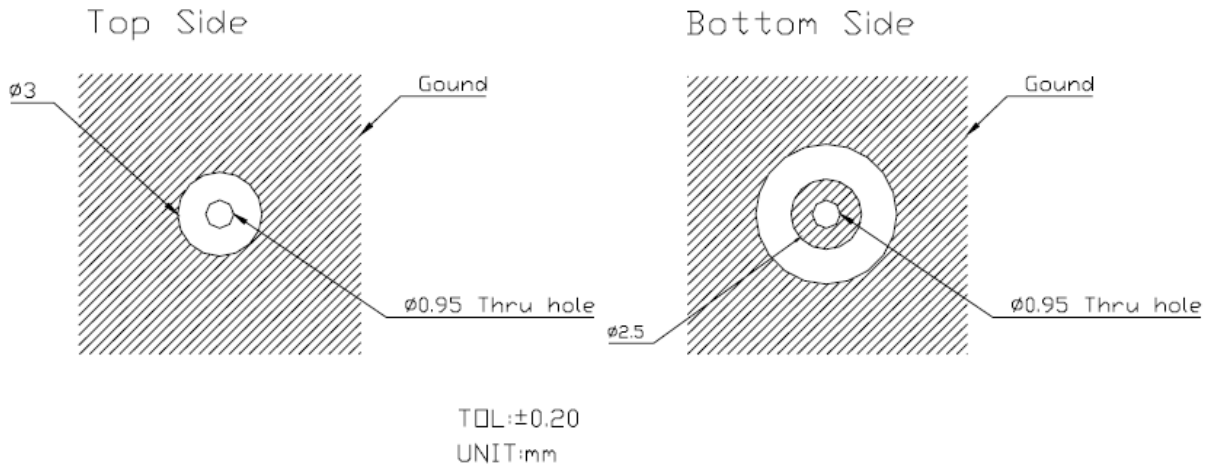

5.2 Test Jig and Dimension

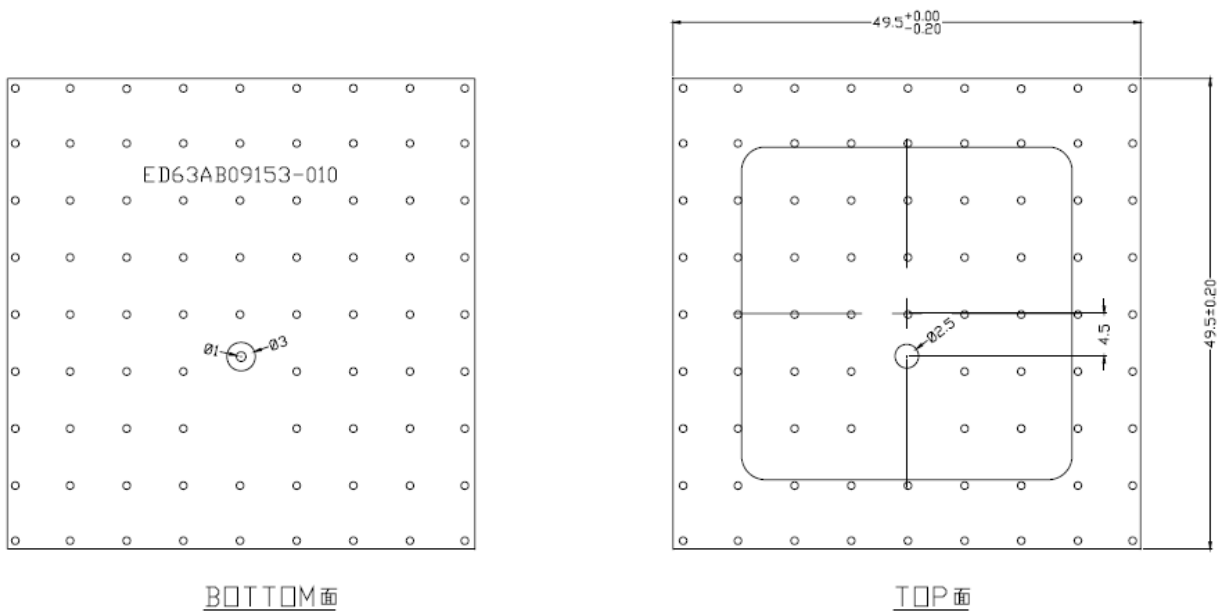

5.3 Test Fixture Antenna Setup and Measurements

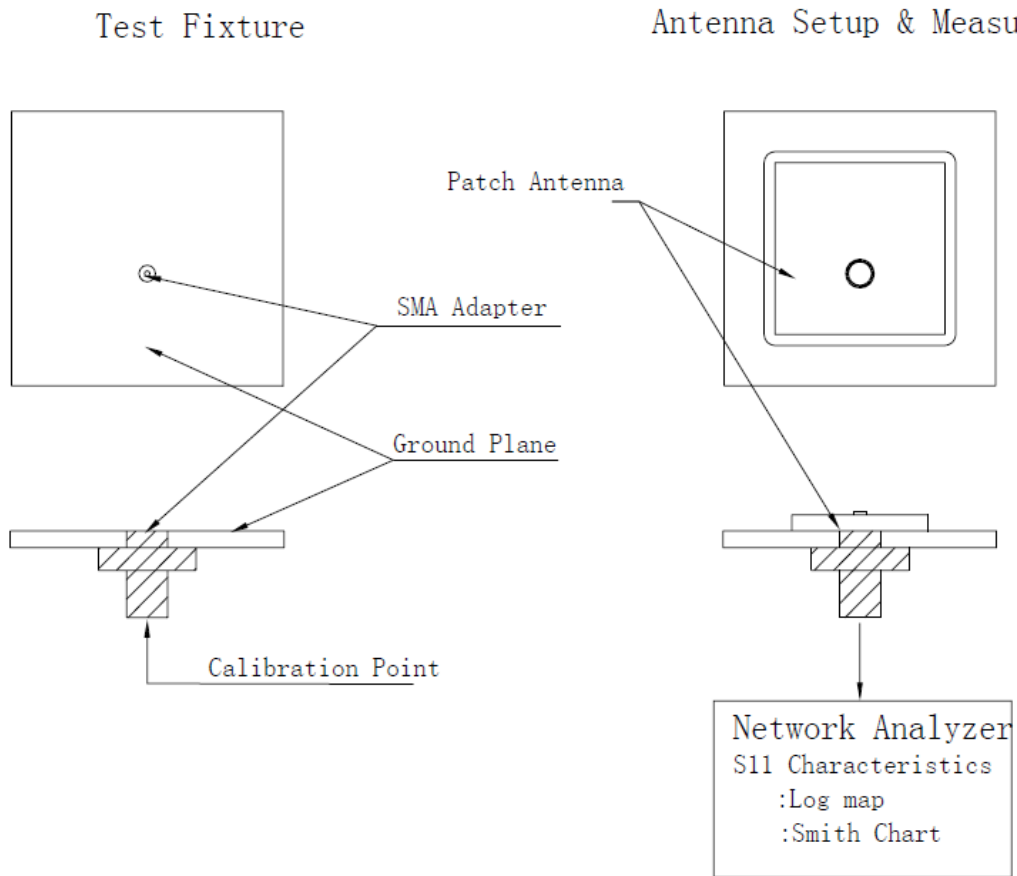

6. Packing

