

iC-NQL

13-bit Sin/D CONVERTER WITH SSI INTERFACE



Rev D2, Page 1/24

FEATURES

- Resolution of up to 8192 angle steps per sine/cosine period
- Binary and decimal resolution settings, e.g. 500, 512, 1000, 1024; programmable angle hysteresis
- Conversion time of just 250 ns including amplifier settling
- Count-safe vector follower principle, realtime system with 70 MHz sampling rate
- Direct sensor connection; selectable input gain
- Front-end signal conditioning features offset (8 bit), amplitude ratio (5 bit) and phase (6 bit) calibration
- 250 kHz input frequency
- Absolute angle output via fast SSI interface
- A QUAD B incremental outputs with selectable minimum transition distance (e.g. 0.25 μ s for 1 MHz at A)
- Index signal processing adjustable in position and width
- Fault monitoring: frequency, amplitude, configuration (CRC)
- Setup via serial EEPROM
- ESD protection and TTL-/CMOS-compatible outputs

APPLICATIONS

- Interpolator IC for position data acquisition from analog sine/cosine sensors
- Optical linear/rotary encoders
- MR sensor systems

PACKAGES

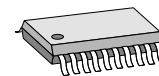

TSSOP20

BLOCK DIAGRAM

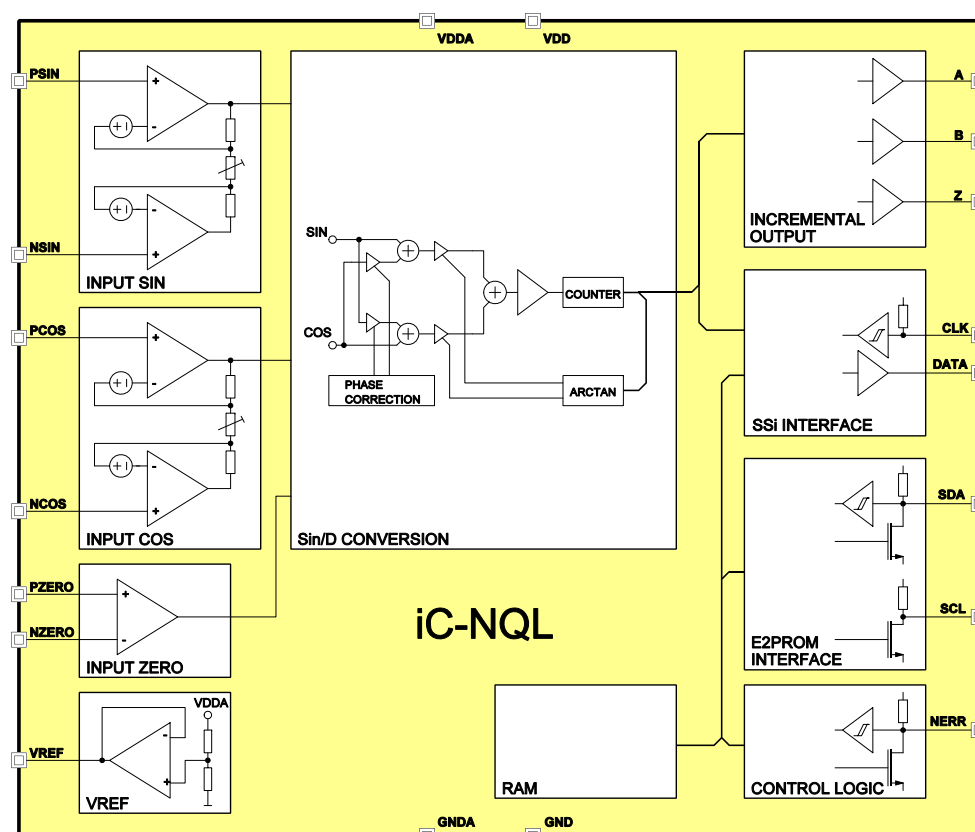

DESCRIPTION

iC-NQL is a monolithic A/D converter which, by applying a count-safe vector follower principle, converts sine/cosine sensor signals with a selectable resolution and hysteresis into angle position data. This absolute value is output via a synchronous-serial SSI interface and trails a master clock rate of up to 4 Mbit/s.

At the same time any changes in output data are converted into incremental A QUAD B encoder signals. Here, the minimum transition distance can be adapted to suit the system on hand (cable length, external counter). A synchronised zero index is generated and output to Z if enabled by the PZERO and NZERO inputs.

The front-end amplifiers are configured as instrumentation amplifiers, permitting sensor bridges to be di-

rectly connected without the need for external resistors. Various programmable D/A converters are available for the conditioning of sine/cosine sensor signals with regard to offset, amplitude ratio and phase errors. Front-end gain can be set in stages graded to suit all common differential sensor signals from approximately 20 mVpp to 1.5 Vpp, and also single-ended sensor signals from 40 mVpp to 3 Vpp respectively.

The device reads its configuration data via the serial EEPROM interface when cycling power, respectively following an undervoltage reset. The read in cycle is repeated up to three times when data correctness is not confirmed by a CRC validation. A permanent CRC error as well as the configuration phase itself is displayed at the error message output NERR by a low level signal.

CONTENTS

PACKAGES	4	Incremental output to A, B and Z	14
ABSOLUTE MAXIMUM RATINGS	5	INCREMENTAL SIGNALS	15
THERMAL DATA	5	SIGNAL MONITORING and ERROR MESSAGES	17
ELECTRICAL CHARACTERISTICS	6	TEST FUNCTIONS	18
ELECTRICAL CHARACTERISTICS: Diagrams	8	SSI INTERFACE	19
OPERATING REQUIREMENTS: SSI INTERFACE	8	EEPROM INTERFACE and STARTUP BEHAVIOUR	20
PARAMETERS and REGISTERS	10	Example of CRC Calculation Routine	20
SIGNAL CONDITIONING	11	APPLICATION HINTS	21
CONVERTER FUNCTIONS	12	Principle Input Circuits	21
MAXIMUM POSSIBLE CONVERTER FREQUENCY	13	Basic Circuit	22
Serial data output	13	DESIGN REVIEW: Notes On Chip Functions	23

PACKAGES TSSOP20 (according to JEDEC Standard)

PIN CONFIGURATION

TSSOP20 4.4 mm, lead pitch 0.65 mm

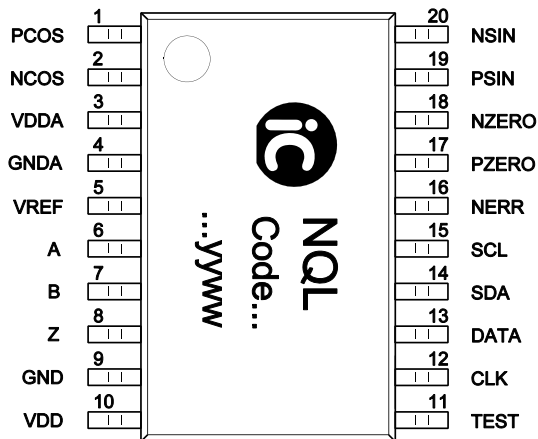

PIN FUNCTIONS

No.	Name	Function
1	PCOS	Input Cosine +
2	NCOS	Input Cosine -
3	VDDA	+5 V Supply Voltage (analog)
4	GNDA	Ground (analog)
5	VREF	Reference Voltage Output
6	A	Incremental Output A Analog signal COS+ (TMA mode) PWM signal for Offset Sine (Calib.)
7	B	Incremental Output B Analog signal COS- (TMA mode) PWM signal for Offset Cosine (Calib.)
8	Z	Output Index Z PWM signal for Phase/Ratio (Calib.)
9	GND	Ground
10	VDD	+5 V Supply Voltage (digital)
11	TEST	Test Input
12	CLK	SSI interface, clock line
13	DATA	SSI interface, data output
14	SDA	EEPROM interface, data line Analog signal SIN+ (TMA mode)
15	SCL	EEPROM interface, clock line Analog signal SIN- (TMA mode)
16	NERR	Error Input/Output, active low
17	PZERO	Input Zero Signal +
18	NZERO	Input Zero Signal -
19	PSIN	Input Sine +
20	NSIN	Input Sine -

External connections linking VDDA to VDD and GND to GNDA are required. The test input may remain unwired or can be linked to VDD (please note the hints given by chapter Design Review regarding the signal of pin DATA).

ABSOLUTE MAXIMUM RATINGS

These ratings do not imply operating conditions; functional operation is not guaranteed. Beyond these ratings device damage may occur.

Item No.	Symbol	Parameter	Conditions	Limits		Unit
				Min.	Max.	
G001	VDDA	Voltage at VDDA		-0.3	6	V
G002	VDD	Voltage at VDD		-0.3	6	V
G003	Vpin()	Voltage at PSIN, NSIN, PCOS, NCOS, PZERO, NZERO, VREF, NERR, SCL, SDA, CLK, DATA, A, B, Z	V() < VDDA + 0.3 V V() < VDD + 0.3 V	-0.3	6	V
G004	I _{mx} (VDDA)	Current in VDDA		-50	50	mA
G005	I _{mx} (GNDA)	Current in GNDA		-50	50	mA
G006	I _{mx} (VDD)	Current in VDD		-50	50	mA
G007	I _{mx} (GND)	Current in GND		-50	50	mA
G008	I _{mx} ()	Current in PSIN, NSIN, PCOS, NCOS, PZERO, NZERO, VREF, NERR, SCL, SDA, CLK, DATA, A, B, Z		-10	10	mA
G009	I _{lu} ()	Pulse Current in all pins (Latch-up Strength)	according to Jedec Standard No. 78; T _a = 25 °C, pulse duration to 10 μs, VCC = VCC _{max} , VDD = VDD _{max} , V _{lu} () = (-0.5...+1.5) x V _{pin} () _{max}	-100	100	mA
G010	V _d ()	ESD Susceptibility at all pins	HBM 100 pF discharged through 1.5 kΩ		2	kV
G011	T _j	Junction Temperature		-40	150	°C
G012	T _s	Storage Temperature Range		-40	150	°C

THERMAL DATA

Operating Conditions: VDDA = VDD = 5 V ±10 %

Item No.	Symbol	Parameter	Conditions	Limits			Unit
				Min.	Typ.	Max.	
T01	T _a	Operating Ambient Temperature Range (extended temperature range of -40 to 125 °C available on request)		-25		85	°C

All voltages are referenced to ground unless otherwise stated.

All currents flowing into the device pins are positive; all currents flowing out of the device pins are negative.

ELECTRICAL CHARACTERISTICS

Operating Conditions: VDDA = VDD = 5 V ±10 %, T_j = -40 ... 125 °C, unless otherwise stated

Item No.	Symbol	Parameter	Conditions				Unit
				Min.	Typ.	Max.	
Total Device							
Functionality and parameters beyond the operating conditions (with reference to independent voltage supplies, for instance) are to be verified within the individual application using FMEA methods.							
001	VDDA, VDD	Permissible Supply Voltage		4.5		5.5	V
002	I(VDDA)	Supply Current in VDDA	fin() = 200 kHz; A, B, Z open			15	mA
003	I(VDD)	Supply Current in VDD	fin() = 200 kHz; A, B, Z open			20	mA
004	Von	Turn-on Threshold VDDA, VDD		3.2		4.4	V
005	Vhys	Turn-on Threshold Hysteresis		200			mV
006	Vc()hi	Clamp Voltage hi at PSIN, NSIN, PCOS, NCOS, PZERO, NZERO, VREF	Vc()hi = V() - VDDA; I() = 1 mA, other pins open	0.3		1.6	V
007	Vc()lo	Clamp Voltage lo at PSIN, NSIN, PCOS, NCOS, PZERO, NZERO, VREF, NERR, SCL, SDA, A, B, Z	I() = -1 mA, other pins open	-1.6		-0.3	V
008	Vc()hi	Clamp Voltage hi at NERR, SCL, SDA, A, B, Z	Vc()hi = V() - VDD; I() = 1 mA, other pins open	0.3		1.6	V
Input Amplifiers PSIN, NSIN, PCOS, NCOS							
101	Vos()	Input Offset Voltage	Vin() and G() in accordance with table GAIN; G ≥ 20 G < 20	-10 -15		10 15	mV mV
102	TCos	Input Offset Voltage Temperature Drift	see 101		±10		µV/K
103	Iin()	Input Current	V() = 0 V ... VDDA	-50		50	nA
104	GA	Gain Accuracy	G() in accordance with table GAIN	95		102	%
105	GArel	Gain SIN/COS Ratio Accuracy	G() in accordance with table GAIN	97		103	%
106	fhc	Cut-off Frequency	G = 80 G = 2.667	150 630			kHz kHz
107	SR	Slew Rate	G = 80 G = 2.667	2.3 8.0			V/µs V/µs
Sin/D Conversion: Accuracy							
201	AAabs	Absolute Angle Accuracy without calibration	referred to 360° input signal, G = 2.667, Vin = 1.5 Vpp, HYS = 0	-1.0		1.0	DEG
202	AAabs	Absolute Angle Accuracy after calibration	referred to 360° input signal, HYS = 0, internal signal amplitude of 2 ... 4 Vpp	-0.5	±0.35	+0.5	DEG
203	AArel	Relative Angle Accuracy	referred to output signal period of A/B, G = 2.667, Vin = 1.5 Vpp, SELRES = 1024, FCTR = 0x0004 ... 0x00FF, fin < fin _{max} (see table 14)	-10		10	%
Reference Voltage VREF							
801	VREF	Reference Voltage	I(VREF) = -1 mA ... +1 mA	48		52	% VDDA
Oscillator							
A01	fosc()	Oscillator Frequency	presented at SCL with subdivision of 2048; VDDA = VDD = 5 V ±10 % VDDA = VDD = 5 V	52 60	72	90 83	MHz MHz
A02	TCosc	Oscillator Frequency Temperature Drift	VDDA = VDD = 5 V		-0.1		%/K
A03	VCosc	Oscillator Frequency Power Supply Dependence			+10.6		%/V

ELECTRICAL CHARACTERISTICS

Operating Conditions: VDDA = VDD = 5 V ±10 %, Tj = -40 ... 125 °C, unless otherwise stated

Item No.	Symbol	Parameter	Conditions				Unit
				Min.	Typ.	Max.	
Zero Comparator							
B01	Vos()	Input Offset Voltage	V() = Vcm()	-20		20	mV
B02	Iin()	Input Current	V() = 0 V ... VDDA	-50		50	nA
B03	Vcm()	Common-Mode Input Voltage Range		1.4		VDDA-1.5	V
B04	Vdm()	Differential Input Voltage Range		0		VDDA	V
Incremental Outputs A, B, Z							
SSI Interface Output DATA							
D01	Vs()hi	Saturation Voltage hi	Vs()hi = VDD - V(); I() = -4 mA			0.4	V
D02	Vs()lo	Saturation Voltage lo	I() = 4 mA			0.4	V
D03	tr()	Rise Time	CL() = 50 pF			60	ns
D04	tf()	Fall Time	CL() = 50 pF			60	ns
D05	RL()	Permissible Load at A, B	TMA = 1 (calibration mode)	1			MΩ
SSI Interface: Input CLK							
E01	Vt()hi	Threshold Voltage hi				2	V
E02	Vt()lo	Threshold Voltage lo		0.8			V
E03	Vt()hys	Hysteresis	Vt()hys = Vt()hi - Vt()lo	300			mV
E04	Ipu()	Pull-up Current in CLK	V() = 0 ... VDD - 1 V	-240	-120	-25	μA
E05	fclk()	Permissible Clock Frequency at CLK				4	MHz
E06	tp(CLK-DATA)	Propagation Delay: CLK edge vs. DATA output	all modes, RL(SLO) ≥ 1 kΩ	10		50	ns
E07	tbusy()	Processing Time			0		
E08	ttos()	Timeout	CFGTOS = 0x01, iC-NQL_X3 CFGTOS = 0x01, iC-NQL_3		16 20		μs μs
EEPROM Interface, Control Logic: Inputs SDA, NERR							
F01	Vt()hi	Threshold Voltage hi				2	V
F02	Vt()lo	Threshold Voltage lo		0.8			V
F03	Vt()hys	Hysteresis	Vt()hys = Vt()hi - Vt()lo	300			mV
F04	tbusy()cfg	Duration of Startup Configuration	error free EEPROM access		5	7	ms
EEPROM Interface, Control Logic: Outputs SDA, SCL, NERR							
G01	f()	Write/Read Clock at SCL			20	100	kHz
G02	Vs()lo	Saturation Voltage lo	I() = 4 mA			0.45	V
G03	Ipu()	Pull-up Current	V() = 0 ... VDD - 1 V	-600	-300	-75	μA
G04	ft()	Fall Time	CL() = 50 pF			60	ns
G05	tmin()lo	Error Signal Indication Time at NERR (lo signal)	CLK = hi, no amplitude or frequency error	10			ms
G06	Tpwm()	Duty Cycle Of Error Indication at NERR	fosc() subdivided by 2 ²²		60.7		ms
G07	t()lo	Duty Cycle Of Error Indication at NERR	signal duration low to high; AERR = 0 (amplitude error) FERR = 0 (frequency error)		75 50		% %
G08	RL()	Permissible Load at SDA, SCL	TMA = 1 (calibration mode)	1			MΩ

ELECTRICAL CHARACTERISTICS: Diagrams

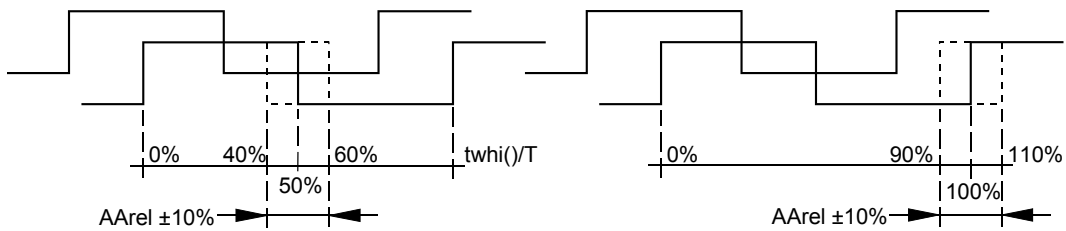

Figure 1: Definition of relative angle error.

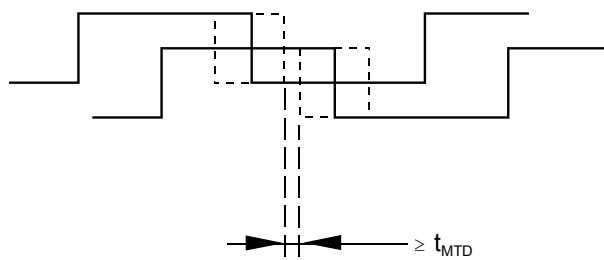

Figure 2: Definition of minimum transition distance.

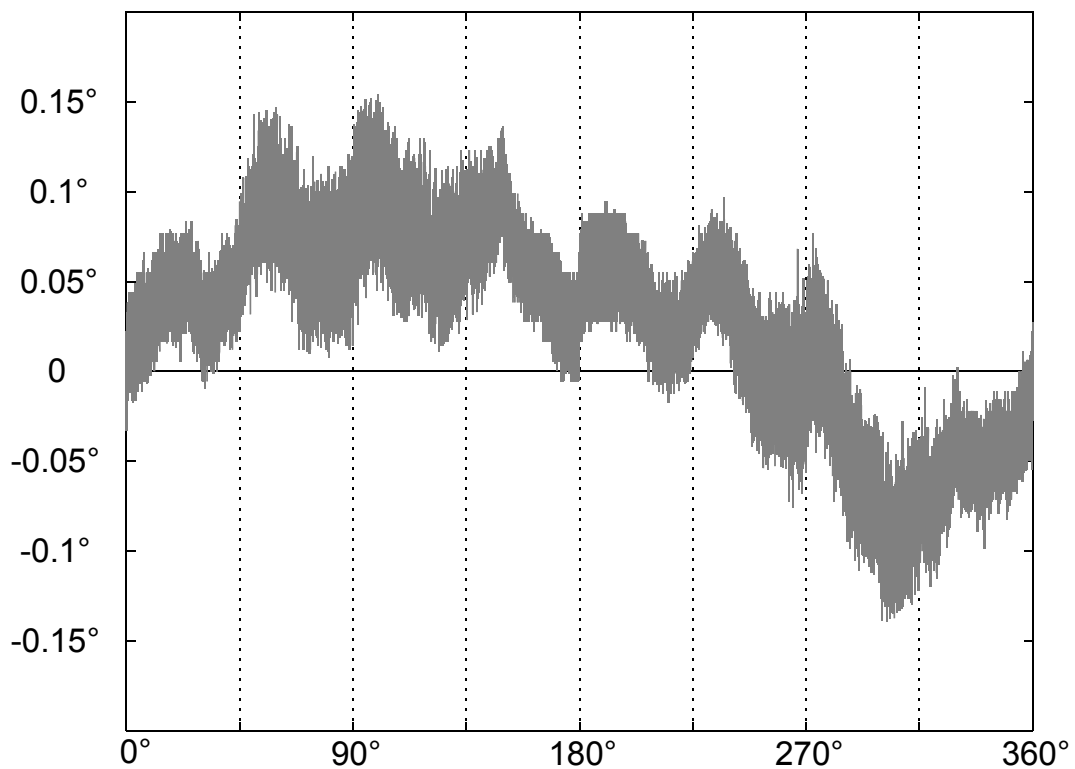

Figure 3: Typical residual absolute angle error after calibration.

OPERATING REQUIREMENTS: SSI INTERFACE

Operating Conditions: VDD = 5 V ±10 %, Ta = -25 ... 85 °C; input levels lo = 0 ... 0.45 V, hi = 2.4 V ... VDD

Item No.	Symbol	Parameter	Conditions	Fig.			Unit
					Min.	Max.	
I001	T _{CLK}	Permissible Clock Period	CFGTOS = 0x01	4	250	2x t _{tos}	ns
I002	t _{CLKhi}	Clock Signal Hi Level Duration		4	25	t _{tos}	ns
I003	t _{CLKlo}	Clock Signal Lo Level Duration		4	25	t _{tos}	ns

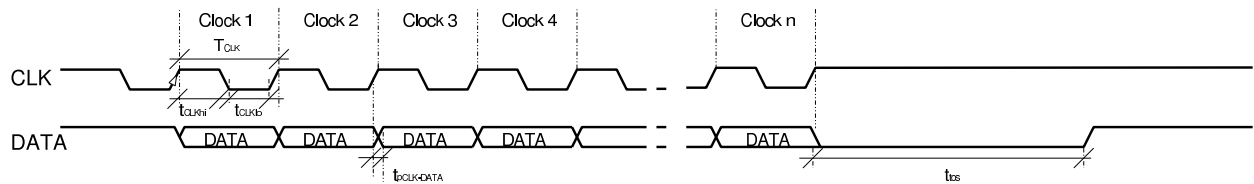

Figure 4: Timing diagram of SSI output.

PARAMETERS and REGISTERS

Register Description	Page 10	ZPOS:	Zero Signal Position
Signal Conditioning	Page 11	CFGZ:	Zero Signal Length
GAIN:	Gain Select	CFGAB:	Zero Signal Logic
SINOFFS:	Offset Calibration Sine	Signal Monitoring	
COSOFFS:	Offset Calibration Cosine	and Error Messages	Page 17
REFOFFS:	Offset Calibration Reference	SELAMPL:	Amplitude Monitoring, function
RATIO:	Amplitude Calibration	AMPL:	Amplitude Monitoring, thresholds
PHASE:	Phase Calibration	AERR:	Amplitude Error
Converter Function	Page 12	FERR:	Frequency Error
SELRES:	Resolution	Test Functions	Page 18
HYS:	Hysteresis	TMODE:	Test Mode
FCTR:	Max. Permissible Converter Frequency	TMA:	Analog Test Mode
Incremental Signals	Page 15	SSI Interface	Page 19
CFGABZ:	Output A, B, Z	CFGTOS:	Interface Timeout
ROT:	Direction of Rotation	CFGSSI:	SSI Output Options
ENRESDEL:	Output Turn-On Delay		

OVERVIEW								
Adr	Bit 7	Bit 6	Bit 5	Bit 4	Bit 3	Bit 2	Bit 1	Bit 0
0x00	0	0	0	SELRES(4:0)				
0x01	HYS(2:0)			ZPOS(4:0)				
0x02	ENRESDEL	1	ROT	0	CFGABZ(1:0)		CFGZ(1:0)	
0x03	CFGSSI(1:0)		CFGAB(1:0)		0	0	AERR	FERR
0x04	FCTR(7:0)							
0x05	0	FCTR(14:8)						
0x06	0	0	CFGTOS(1:0)		TMODE(2:0)			TMA
0x07	0	0	0	0	0	0	0	0
0x08	GAIN(3:0)				RATIO(3:0)			
0x09	SINOFFS(7:0)							
0x0A	COSOFFS(7:0)							
0x0B	PHASE(5:0)						REFOFFS	RATIO(4)
0x0C	0	0	0	0	0	SELAMPL	AMPL(1:0)	
0x0D	0	0	0	0	0	0	0	0
0x0E	0	0	0	0	0	0	0	0
0x0F	CRC_E2P(7:0) - check value read from the EEPROM for addresses 0x00 to 0x0E							
Note	Registers not in use must be set to zero unless otherwise noted.							

Table 5: Register layout

SIGNAL CONDITIONING

Input stages SIN and COS are configured as instrumentation amplifiers. The amplifier gain must be selected in accordance with the sensor signal level and

programmed to register GAIN according to the following table. Half of the supply voltage is output to VREF as center voltage to help DC level adaptation.

GAIN		Sine/Cosine Input Signal Levels Vin()			
Code	Amplification	Amplitude		Average value (DC)	
		Differential	Single-ended	Differential	Single-ended
0x0F	80.000	up to 50 mVpp	up to 100 mVpp	0.7 V ... VDDA - 1.2 V	0.8 V ... VDDA - 1.2 V
0x0E	66.667	up to 60 mVpp	up to 120 mVpp	0.7 V ... VDDA - 1.2 V	0.8 V ... VDDA - 1.2 V
0x0D	53.333	up to 75 mVpp	up to 0.15 Vpp	0.7 V ... VDDA - 1.2 V	0.8 V ... VDDA - 1.2 V
0x0C	40.000	up to 0.1 Vpp	up to 0.2 Vpp	1.2 V ... VDDA - 1.2 V	1.3 V ... VDDA - 1.3 V
0x0B	33.333	up to 0.12 Vpp	up to 0.24 Vpp	1.2 V ... VDDA - 1.2 V	1.3 V ... VDDA - 1.3 V
0x0A	28.571	up to 0.14 Vpp	up to 0.28 Vpp	0.7 V ... VDDA - 1.2 V	0.8 V ... VDDA - 1.3 V
0x09	26.667	up to 0.15 Vpp	up to 0.3 Vpp	1.2 V ... VDDA - 1.2 V	1.3 V ... VDDA - 1.3 V
0x08	20.000	up to 0.2 Vpp	up to 0.4 Vpp	0.7 V ... VDDA - 1.2 V	0.8 V ... VDDA - 1.3 V
0x07	14.287	up to 0.28 Vpp	up to 0.56 Vpp	1.2 V ... VDDA - 1.3 V	1.4 V ... VDDA - 1.4 V
0x06	10.000	up to 0.4 Vpp	up to 0.8 Vpp	1.2 V ... VDDA - 1.3 V	1.4 V ... VDDA - 1.5 V
0x05	8.000	up to 0.5 Vpp	up to 1 Vpp	0.8 V ... VDDA - 1.4 V	1.0 V ... VDDA - 1.6 V
0x04	6.667	up to 0.6 Vpp	up to 1.2 Vpp	0.8 V ... VDDA - 1.4 V	1.1 V ... VDDA - 1.7 V
0x03	5.333	up to 0.75 Vpp	up to 1.5 Vpp	0.9 V ... VDDA - 1.5 V	1.3 V ... VDDA - 1.9 V
0x02	4.000	up to 1 Vpp	up to 2 Vpp	1.2 V ... VDDA - 1.6 V	1.7 V ... VDDA - 2.1 V
0x01	3.333	up to 1.2 Vpp	up to 2.4 Vpp	1.2 V ... VDDA - 1.7 V	1.8 V ... VDDA - 2.3 V
0x00	2.667	up to 1.5 Vpp	up to 3 Vpp	1.3 V ... VDDA - 1.8 V	2.0 V ... VDDA - 2.6 V

Table 6: Gain Select

SINOFFS			Adr 0x09, Bit 7:0		
COSOFFS			Adr 0x0A, Bit 7:0		
Code	Output Offset	Input Offset			
0x00	0 V	0 V			
0x01	-7.8125 mV	-7.8125* mV / GAIN			
...			
0x7F	-0.9922 V	-0.9922 V / GAIN			
0x80	0 V	0 V			
0x81	+7,8125 mV	+7.8125 mV / GAIN			
...			
0xFF	+0.9922 V	+0.9922 V / GAIN			
Notes	*) With REFOFFS = 0x00 und VDDA = 5 V.				

Table 7: Offset Calibration Sine/Cosine

REFOFFS		Adr 0x0B, Bit 1	
Code	Reference Voltage		
0x00	Depending on VDDA (example of application: MR sensors)		
0x01	Not depending on VDDA (example of application: Sin/Cos encoders)		

Table 8: Offset Calibration Reference

RATIO				Adr 0x0B, Bit 0, Adr 0x08, Bit 3:0			
Code	COS / SIN	Code	COS / SIN				
0x00	1.0000	0x10	1.0000				
0x01	1.0067	0x11	0.9933				
...				
0x0F	1.1	0x1F	0.9000				

Table 9: Amplitude Calibration

PHASE				Adr 0x0B, Bit 7:2			
Code	Phase Shift	Code	Phase Shift				
0x00	90°	0x20	90°				
0x01	90.703125°	0x21	89.296875°				
...				
0x12	102.65625°	0x32	77.34375°				
...	102.65625°	...	77.34375°				
0x1F	102.65625°	0x3F	77.34375°				

Table 10: Phase Calibration

CONVERTER FUNCTIONS

SELRES Adr 0x00, Bit 4:0		
Code	Binary Resolutions	Examples of Permissible Input Frequencies f_{inmax} (FCTR 0x0004, 0x4304)
0x00	-	
0x01	-	
0x02	-	
0x03	8192	158 Hz, 635 Hz
0x04	4096	317 Hz, 1.27 kHz
0x05	2048	634 Hz, 2.54 kHz
0x06	1024	1.27 kHz, 5.1 kHz
0x07	512	2.54 kHz, 10.2 kHz
0x08	256	5.1 kHz, 20.3 kHz
0x09	128	10.2 kHz, 40.6 kHz
0x0A	64	20.3 kHz, 81.3 kHz
0x0B	32	40.6 kHz, 162.5 kHz
0x0C	16	81.3 kHz (max. 250 kHz @ 0x4202)
0x0D	8	162 kHz (max. 250 kHz @ 0x4102)
0x0E	-	
0x0F	-	

Table 11: Binary Resolutions

SELRES Adr 0x00, Bit 4:0		
Code	Decimal Resolutions	Examples of Permissible Input Frequencies f_{inmax} (FCTR 0x0004, 0x4304)
0x10	2000	650 Hz, 2.6 kHz
0x11	1600	812 Hz, 3.3 kHz
0x12	1000	1.3 kHz, 5.2 kHz
0x13	800	1.6 kHz, 6.5 kHz
0x14	500	2.6 kHz, 10.4 kHz
0x15	400	3.2 kHz, 13 kHz
0x16	250 ^{*1}	5.2 kHz, 20.8 kHz
0x17	125 ^{*1,2}	5.2 kHz, 20.8 kHz
0x18	320	4.1 kHz, 16.3 kHz
0x19	160 ^{*2}	4.1 kHz, 16.3 kHz
0x1A	80 ^{*4}	4.1 kHz, 16.3 kHz
0x1B	40 ^{*8}	4.1 kHz, 16.3 kHz
0x1C	200	6.5 kHz, 26 kHz
0x1D	100 ^{*2}	6.5 kHz, 26 kHz
0x1E	50 ^{*1,4}	6.5 kHz, 26 kHz
0x1F	25 ^{*1,8}	6.5 kHz, 26 kHz
Notes	^{*1} Not useful with incremental A quad B output. ^{*2,4,8} The internal converter resolution is higher by a factor of 2, 4 or 8.	

Table 12: Decimal Resolutions

HYS Adr 0x01, Bit 7:5			
Code	Hysteresis in degree	Hysteresis in LSB	Absolute Angle Error*
0x00	0°		
0x01	0.0879°	1 LSB @ 12 bit	0.044°
0x02	0.1758°	1/2 LSB @ 10 bit	0.088°
0x03	0.3516°	1 LSB @ 10 bit	0.176°
0x04	0.7031°	1/2 LSB @ 8 bit	0.352°
0x05	1.4063°	1 LSB @ 8 bit	0.703°
0x06	5.625°		2.813°
0x07	45°	only recommended for calibration	22.5°
Notes	*) The absolute angle error is equivalent to one half the angle hysteresis		

Table 13: Hysteresis

MAXIMUM POSSIBLE CONVERTER FREQUENCY

The converter frequency automatically adjusts to the value necessary for the input frequency and resolution. This value ranges from zero to a maximum dependent on the oscillator frequency which can be set using register FCTR.

feature can be enabled via the FCTR register. Should the input frequency exceed the frequency limit of the selected converter resolution, the LSB is kept stable and not resolved any further; the interpolation resolution halves.

Serial data output

For SSI output the maximum possible converter frequency can be adjusted to suit the maximum input frequency; an automatic converter resolution step-down

If the next frequency limit is overshoot, the LSB and the LSB+1 are kept stable and so on. When the input frequency again sinks below this frequency limit, the fine resolution automatically returns.

Max. Possible Converter Frequency For Serial Data Output									
FCTR	Resolution Requirements			Protocol SSI	Max. Input Frequency $f_{in_{max}}$	Restrictions at high input frequency	Examples* $f_{in_{max}}$ [kHz] at resol.		
	Min. Res.	bin	dec				8192	1024	200
0x0004		X	X	X	$f_{osc}()min / 40 / Resolution$	-	0.16	1.27	6.5
0x4102	≥ 8	X	X	X	$f_{osc}()min / 24 / Resolution$	Rel. angle error 2x increased	0.26	2.1	10.8
0x4202	≥ 16	X	X	X	$2 \times f_{osc}()min / 24 / Res.$	Rel. angle error 4x increased	0.53	4.2	21.6
0x4304	≥ 32	X	X	X	$4 \times f_{osc}()min / 40 / Res.$	Rel. angle error 8x increased	0.64	5.1	26.0
0x4602	≥ 64	X	-	X	$4 \times f_{osc}()min / 24 / Res.$	Resolution lowered by factor of 2	1.1	8.5	-
0x4A02	≥ 128	X	-	X	$8 \times f_{osc}()min / 24 / Res.$	Res. lowered by factor of 2-4	2.1	16.9	-
0x4E02	≥ 256	X	-	X	$16 \times f_{osc}()min / 24 / Res.$	Res. lowered by factor of 2-8	4.2	33.8	-
0x5202	≥ 512	X	-	X	$32 \times f_{osc}()min / 24 / Res.$	Res. lowered by factor of 2-16	8.5	67.7	-
0x5602	≥ 1024	X	-	X	$64 \times f_{osc}()min / 24 / Res.$	Res. lowered by factor of 2-32	16.9	135	-
0x5A02	≥ 2048	X	-	X	$128 \times f_{osc}()min / 24 / Res.$	Res. lowered by factor of 2-64	33.8	250	-
0x5E02	≥ 4096	X	-	X	$256 \times f_{osc}()min / 24 / Res.$	Res. lowered by factor of 2-128	67.7	-	-
0x6202	8192	X	-	X	$512 \times f_{osc}()min / 24 / Res.$	Res. lowered by factor of 2-256	135	-	-
Notes	*) Calculated with $f_{osc}()min$ taken from Electrical Characteristics item A01.								

Table 14: Maximum converter frequency for serial data output.

Incremental output to A, B and Z

There are two criteria which must be considered when setting the maximum possible converter frequency via the FCTR register:

1. The maximum input frequency
2. System limitations, e.g. due to slow counters or cable transmission

When facing system limitations it is useful to preselect a minimum transition distance for the output sig-

nals. A digital zero-delay glitch filter then takes care of a temporal edge-to-edge separation, guaranteeing spike-free output signals after an ESD impact to the sensor, for instance.

A serial data output is simultaneously possible at any time. However, for the transfer of angle data to the output register the incremental output is halted for one period of the clock signal applied to pin CLK.

1. Max. Possible Converter Frequency Defined By The Maximum Input Frequency									
FCTR	Output Frequency f_{out} @ $f_{in_{max}}$ A, B	Resolution Requirem.		Maximum Input Frequency $f_{in_{max}}$	Restrictions at high input frequency	Examples* $f_{in_{max}}$ [kHz] at resol.			
		bin	dec			8192	1024	200	
0x0004	325 kHz	X	X	$f_{osc}()_{min} / 40 / \text{Resolution}$	None	0.16	1.27	6.5	
0x4102	542 kHz	X	X	$f_{osc}()_{min} / 24 / \text{Resolution}$	Relative angle error 2x increased	0.26	2.1	10.8	
0x4202	1.08 MHz	X	X	$2 \times f_{osc}()_{min} / 24 \text{ Res.}$	Relative angle error 4x increased	0.53	4.2	21.6	
0x4304	1.3 MHz	X	X	$4 \times f_{osc}()_{min} / 40 / \text{Res.}$	Relative angle error 8x increased	0.64	5.1	26.0	
Notes	*) Calculated with $f_{osc}()_{min}$ taken from Electrical Characteristics item A01.								

Table 15: Max. converter frequency for incremental A/B/Z output, defined by the max. input frequency

2. Max. Possible Converter Frequency Defined By The Minimum Transition Distance						
FCTR	Output Frequency f_{out} @ t_{MTD} A, B	Resolution Requirem.		Minimum Transition Distance at A, B t_{MTD}	Restrictions at high input frequency	Example* t_{MTD} [µsec]
		bin	dec			
0x00FF	11 kHz	X	X	$2048 / f_{osc}()_{max}$	None	22.8
0x00FE	11.03 kHz	X	X	$2040 / f_{osc}()_{max}$	None	22.7
0x00FD	11.07 kHz	X	X	$2032 / f_{osc}()_{max}$	None	22.6
...
0x0006	402 kHz	X	X	$56 / f_{osc}()_{max}$	None	0.62
0x0005	536 kHz	X	X	$48 / f_{osc}()_{max}$	None	0.53
0x0004	562 kHz	X	X	$40 / f_{osc}()_{max}$	None	0.44
0x4102	938 kHz	X	X	$24 / f_{osc}()_{max}$	Relative angle error 2x increased	0.27
0x4202	1.87 MHz	X	X	$12 / f_{osc}()_{max}$	Relative angle error 4x increased	0.13
0x4304	2.25 MHz	X	X	$10 / f_{osc}()_{max}$	Relative angle error 8x increased	0.11
Notes	*) Calculated with $f_{osc}()_{max}$ taken from El.Char. item A01; the min. transition distance refers to output A vs. output B without reversing the sense of rotation.					

Table 16: Max. converter frequency for incremental A/B/Z output, defined by the min. transition distance

INCREMENTAL SIGNALS

CFGABZ		Adr 0x02, Bit 3:2		
Code	Mode	Pin A	Pin B	Pin Z
0x00	Normal	A	B	Z
0x01	Control signals for external period counters	CA	CB	CZ
0x02	Calibration mode Offset+Phase The following settings are required additionally: SELRES = 0x0D ZPOS = 0x00 HYS = 0x07 ROT = 0x00 CFGAB = 0x00 AERR = 0x00	<p>Figure 5: Offset SIN*</p>	<p>Figure 6: Offs. COS*</p>	<p>Figure 7: Phase*</p>
0x03	Calibration mode Offset+Amplitude The following settings are required additionally: SELRES = 0x0D ZPOS = 0x00 HYS = 0x07 ROT = 0x00 CFGAB = 0x00 AERR = 0x00	<p>Figure 8: Offset SIN*</p>	<p>Figure 9: Offs. COS*</p>	<p>Figure 10: Amplit.*</p>
Notes	*) Trimmed accurately when duty cycle is 50 %; Recommended trimming order (after selecting GAIN): Offset, Phase, Amplitude Ratio, Offset;			

Table 17: Outputs A, B, Z

ROT		Adr 0x02, Bit 5
Code	Direction	
0x00	Not inverted	
0x01	Inverted	

Table 18: Direction of Rotation

ENREDEL			Adr 0x02, Bit 7
Code	Output*	Function	
0x00	immediately	An external counter displays the absolute angle following power on.	
0x01	after 5 ms	An external counter only displays changes vs. the initial power-on condition (moving halted to reapply power is precondition.)	
Notes	*) Output delay after device configuration and internal reset.		

Table 19: Output Turn-On Delay A, B, Z

ZPOS		Adr 0x01, Bit 4:0
Code	Position	
0x00	0°	
0x08	90°	
0x10	180°	
0x18	270°	
Notes	The zero signal is only output if released by the input pins (for instance with PZERO = 5V, NZERO = VREF).	

Table 20: Zero Signal Position

CFGZ		Adr 0x02, Bit 1:0
Code	Length	
0x00	90°	
0x01	180°	
0x02.. 03	Synchronization	

Table 21: Zero Signal Length

CFGAB		Adr 0x03, Bit 5:4
Code	Z = 1 for	
0x00	B = 1, A = 1	
0x01	B = 0, A = 1	
0x02	B = 1, A = 0	
0x03	B = 0, A = 0	

Table 22: Zero Signal Logic

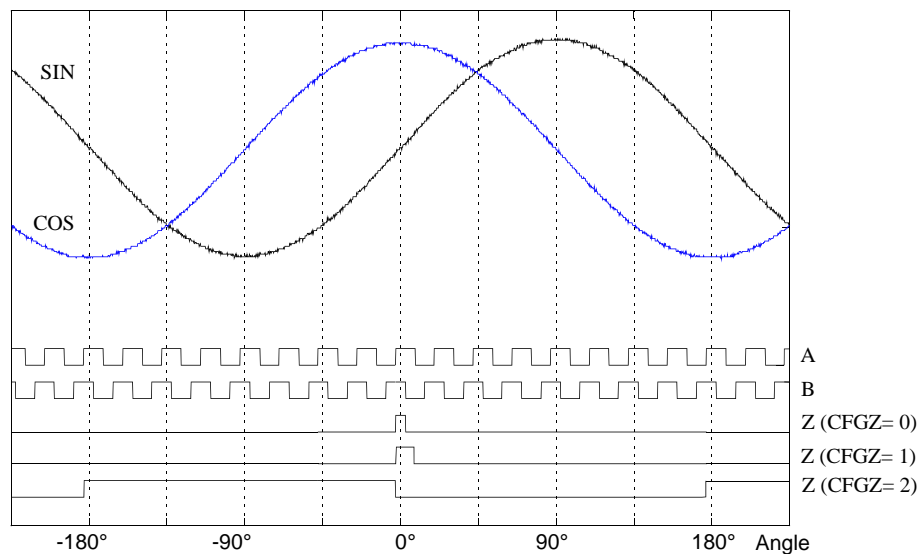

Figure 11: Incremental output signals for various length of the zero signal.

Example for a resolution of 64 (SELRES = 0x0A), a zero signal position of 0° (ZPOS = 0x00, CFGAB = 0x00) and no reversal of the rotational sense (ROT = 0x00, COS leads SIN).

SIGNAL MONITORING and ERROR MESSAGES

SELAMPL		Adr 0x0C, Bit 2	
AMPL		Adr 0x0C, Bit 1:0	
Code	Max (Sin , Cos)	Voltage threshold V_{th}	Output amplitude*
0x00		0.60 x VDDA	1.4 Vpp
0x01		0.64 x VDDA	2.0 Vpp
0x02		0.68 x VDDA	2.6 Vpp
0x03		0.72 x VDDA	3.1 Vpp
		Sin² + Cos²	
Code	$V_{thmin} \leftrightarrow V_{thmax}$		Output amplitude*
Design iC-NQL_X3:			
0x04	(0.48 ↔ 0.68) x VDDA		2.4 Vpp ↔ 3.4 Vpp
0x05	(0.56 ↔ 0.76) x VDDA		2.8 Vpp ↔ 3.8 Vpp
0x06	(0.64 ↔ 0.84) x VDDA		3.2 Vpp ↔ 4.2 Vpp
0x07	(0.72 ↔ 0.92) x VDDA		3.6 Vpp ↔ 4.6 Vpp
Design iC-NQL_3:			
0x04	(0.20 ↔ 0.9) x VDDA		1.0 V _{SS} ↔ 4.5 V _{SS}
0x05	(0.30 ↔ 0.9) x VDDA		1.5 V _{SS} ↔ 4.5 V _{SS}
0x06	(0.40 ↔ 0.9) x VDDA		2.0 V _{SS} ↔ 4.5 V _{SS}
0x07	(0.50 ↔ 0.9) x VDDA		2.5 V _{SS} ↔ 4.5 V _{SS}
Notes	*) Entries are calculated with VDDA = 5V.		

Table 23: Signal Amplitude Monitoring

AERR		Adr 0x03, Bit 1
Code	Amplitude error message	
0x00	disabled	
0x01	enabled	

Table 24: Amplitude Error

FERR		Adr 0x03, Bit 0
Code	Excessive frequency error message	
0x00	disabled	
0x01	enabled	
Note	Input frequency monitoring is operational for resolutions ≥ 16	

Table 25: Frequency Error

Configuration Error	
-	Messaging always released

Table 26: Configuration Error

Error Indication at NERR	
Failure Mode	Pin signal NERR
No error	HI
Amplitude error	LO/HI = 75 %
Frequency error	LO/HI = 50 %
Configuration	LO
Undervoltage	LO
System error	NERR = low by external error signal

Table 27: Error indication at NERR

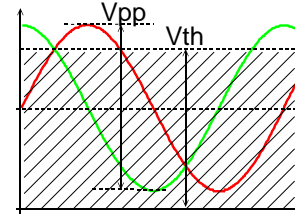

Figure 12: Signal monitoring of minimum amplitude.

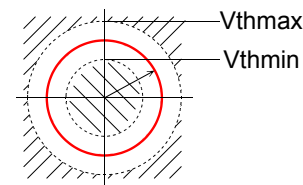

Figure 13: Sin² + Cos² signal monitoring.

To enable the diagnosis of faults, the various types of error are signaled at NERR using a PWM code as given in the key table.

Two error bits are provided to enable communication via the SSI interface; these bits can decode four different types of error. If NERR is held at low by an external source, such as an error message from the system, for example, this can also be verified via the SSI interface.

Error events are stored for the SSI data output and deleted afterwards. Errors at NERR are displayed for a minimum of ca. 10 ms, as far as no SSI readout causes a deletion.

If an error in amplitude occurs the conversion process is terminated and the incremental output signals halted. An error in amplitude rules out the possibility of an error in frequency.

Error Messages SSI	
Failure Mode	Error bits E1, E0 (active low)
No error	1, 1
Amplitude error	0, 1
Frequency error	1, 0
Configuration	0, 0
System error	0, 0 (NERR pulled low by external signal)
Line Signal SLO	iC-NQL_3: Data output is deactivated and SLO permanently high in case of: configuration phase, invalid configuration, undervoltage.

Table 28: Error Messages SSI

TEST FUNCTIONS

TMODE Adr 0x06, Bit 3:1		
Code	Signal at Z	Description
0x00	Z	no test mode
0x01	A xor B	Output A EXOR B
0x02	ENCLK	iC-Haus device test
0x03	NLOCK	iC-Haus device test
0x04	CLK	iC-Haus device test
0x05	DIVC	iC-Haus device test
0x06	PZERO - NZERO	iC-Haus device test
0x07	TP	iC-Haus device test
Condition	CFGABZ = 0x00	

Table 29: Test Mode

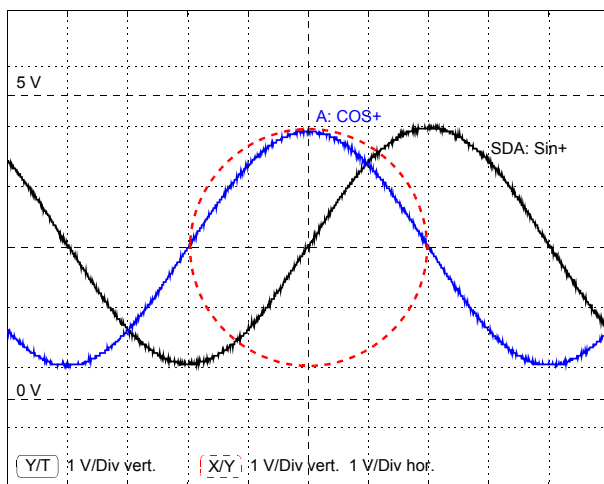

Figure 14: Calibrated signals with TMA mode.

TMA Adr 0x06, Bit 0				
Code	Pin A	Pin B	Pin SDA	Pin SCL
0x00	A	B	SDA	SCL
0x01	COS+	COS-	SIN+	SIN-
Notes	To permit the verification of GAIN and OFFSET settings, the input amplifier outputs are available at the pins. To operate the converter a signal of 4 Vpp is the ideal here and should not be exceeded. Pin loads above 1 MΩ are advisable for accurate measurements.			

Table 30: Analog Test Mode

Parameter GAIN ideally adjusts the signal levels to ca. 4 Vpp and should not be touched afterwards.

Both scope display modes are feasible for OFFS (positive values) or RATIO adjustments; regarding the adjustment of PHASE the X/Y mode may be preferred.

For OFFS adjustment towards negative values the test signals COS- (pin B) and SIN- (pin SCL) are relevant.

SSI INTERFACE

After each communication cycle the SSI interface returns to its idle state when the monoflop timeout t_{tos} has elapsed. This temporal condition also determines up to which clock line pause duration the iC-NQL retains the current data output cycle - the master may thus not undershoot a minimum clock frequency of $f(\text{CLK})_{\text{min}}$.

CFGTOS Adr 0x06, Bit 5:4			
Code	Timeout t_{tos}	Ref. clock counts	$f(\text{CLK})_{\text{min}}^*$
Design iC-NQL_X3:			
0x00	typ. 128 μs	256-259	11 kHz
0x01	typ. 16 μs	32-35	88 kHz
0x02	typ. 4 μs	8-11	352 kHz
0x03	typ. 1 μs	2-5	1.41 MHz
Design iC-NQL_3:			
0x00	typ. 20 μs	46-46	50 kHz
0x01	typ. 20 μs	46-47	50 kHz
0x02	typ. 1.5 μs	3-4	660 kHz
0x03	typ. 1.5 μs	3-4	660 MHz
Notes	A ref. clock count is equal to $\frac{32}{f_{osc}}$ (see El. Char., A01). The permissible max. clock frequency is specified by E05. *) A low clock frequency can reduce the permissible maximum input frequency since conversion is paused after the first falling edge on CLK for a half clock cycle.		

Table 31: Monoflop Time (SSI Timeout)

The iC-NQL position data output contains the angle value (S) with a bit length of 2 to 13 bits (depending on SELRES), and up to 3 add-on bits (error messages E1 and E0 plus a zero bit). Generally, the data output is in binary format starting with the MSB.

Signal Names	
Name	Description
S	Sensor data (S0 is LSB)
E	Error messages
Stop	Low signal

Table 32: Signal Names

The angle conversion is halted for a half clock cycle as soon as the interface receives the first falling edge on CLK, what is the trigger signal to output updated position data. The halt duration must be taken into consideration when calculating the maximum input frequency.

CFGSSI Adr 0x03, Bit 7:6		
Code	Additional bits	Ring register operation
0x00	E1, E0, zero bit	no
0x01	none	no
0x02	not permissible	
0x03	none	yes

Table 33: SSI Output Options

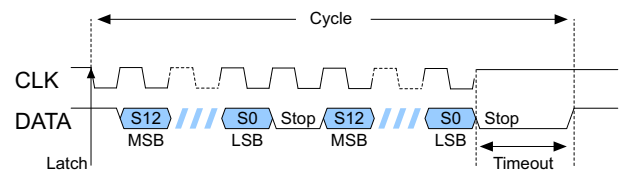

Figure 15: SSI output format during ring register operation. The example displays the transmission of a 13-bit angle value; error messages are switched off herein (SELRES = 0x03, CFGSSI = 0x03)

SSI Output Formats																								
Res	Mode	Error	CRC	T1	T2	T3	T4... T10	T11	T12	T13	T14	T15	T16	T17	T18	T19	T20	T21	T22	T23	T24	T25		
10 bit	SSI	X	-	S9	S8	S7	S6 ... S0	E1	E0	0	Stop	Stop	Stop	Stop	Stop	Stop	Stop	Stop	Stop	Stop	Stop	Stop		
				Example																				
13 bit	SSI ^{*1}	-	-	S12	S11	S10	S9 ... S3	S2	S1	S0	Stop	Stop	Stop	Stop	Stop	Stop	Stop	Stop	Stop	Stop	Stop	Stop		
				Example																				
	SSI-R ^{*2}	-	-	S12	S11	S10	S9 ... S3	S2	S1	S0	Stop	S12	S11	S10	S9	S8	S7	S6	S5	S4	S3	S2		
				Example																				
Configuration Legend				CFGSSI = 0x00; *1) CFGSSI = 0x01; *2) CFGSSI = 0x03 SSI = SSI protocol, SSI-R = SSI ring register operation																				

Table 34: SSI Output Formats

EEPROM INTERFACE and STARTUP BEHAVIOUR

Serial EEPROM components permitting operation from 3.3 V to 5 V can be connected (such as 24C02, for example). When the device is switched on the memory area of bytes 0 to 15 is mapped onto iC-NQL's registers.

After the supply has been turned on (power on reset), iC-NQL reads the configuration data from the EEPROM and during this phase halts error pin NERR actively on a low signal (open drain output).

After a successful CRC the data output to SLO is released and the error indication at pin NERR reset; an external pull-up resistor can supply a high signal. iC-NQL then switches to normal operation and determines the current angle position, providing that a sensor is connected up to it and there is no amplitude error (or this is deactivated).

Should the CRC prove unsuccessful due to a data error (disrupted transmission, no EEPROM or the EEPROM is not programmed), the configuration phase is automatically repeated. After a third failed attempt, the procedure is aborted and error pin NERR remains active, displaying a permanent low.

After startup, iC-NQL does not recognize a defined configuration; the configuration RAM can contain any values.

Example of CRC Calculation Routine

```
unsigned char ucDataStream = 0;
int iCRCPoly = 0x127;
unsigned char ucCRC=0;
int i = 0;

ucCRC = 0; // start value !!!
for (iReg = 0; iReg<15; iReg ++)
{
    ucDataStream = ucGetValue(iReg);
    for (i=0; i<=7; i++) {
        if ((ucCRC & 0x80) != (ucDataStream & 0x80))
            ucCRC = (ucCRC << 1) ^ iCRCPoly;
        else
            ucCRC = (ucCRC << 1);
        ucDataStream = ucDataStream << 1;
    }
}
```

CRC_E2P Adr 0x0F, Bit 7:0	
Code	Description
0x00	Check value formed by CRC polynomial 0x127
...	
0xFF	

Table 35: Check value for EEPROM data

APPLICATION HINTS

Principle Input Circuits

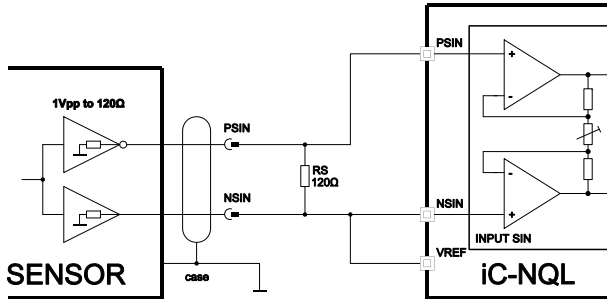

Figure 16: Input circuit for voltage signals of 1Vpp with no ground reference. When grounds are not separated the connection NSIN to VREF must be omitted.

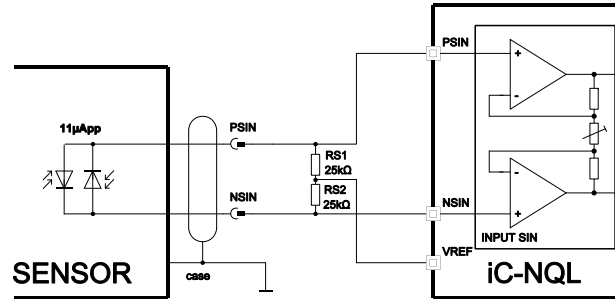

Figure 17: Input circuit for current signals of 11µA. This circuit does not permit offset calibration.

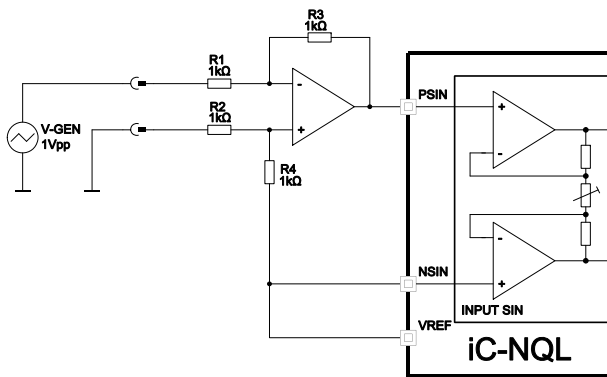

Figure 18: Input circuit for single-sided voltage or current source signals with ground reference (adaptation via resistors R3, R4).

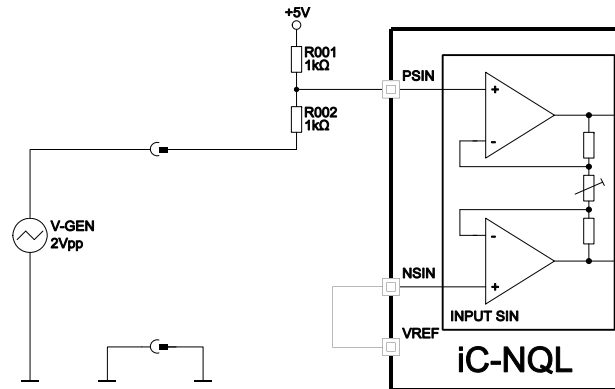

Figure 19: Simplified input wiring for single-sided voltage signals with ground reference.

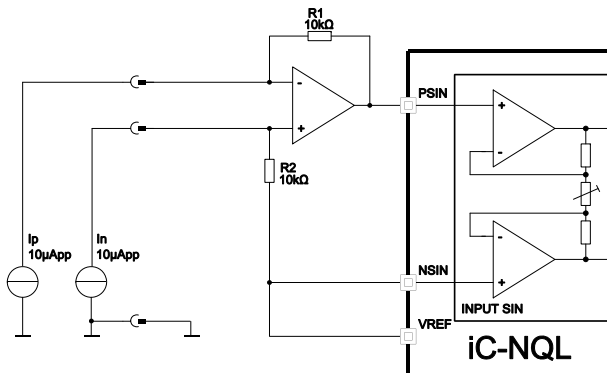

Figure 20: Input circuit for differential current sink sensor outputs, eg. using Opto Encoder iC-WG.

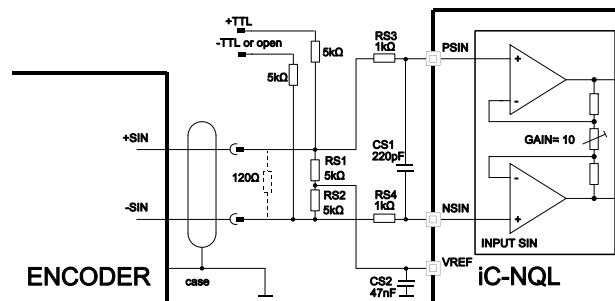

Figure 21: Combined input circuit for 11µA, 1Vpp (with 120Ω termination) or TTL encoder signals. RS3/4 and CS1 serve as protection against ESD and transients.

Basic Circuit

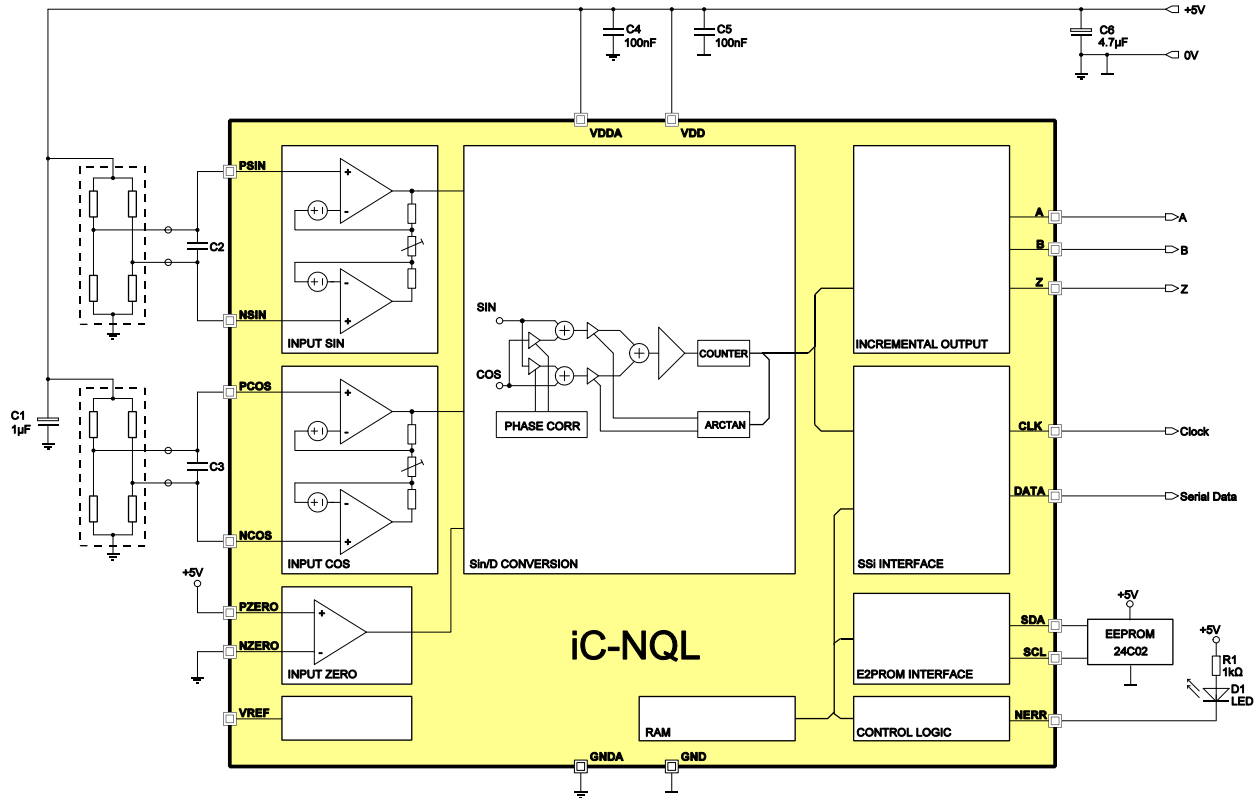

Figure 22: Basic circuit for evaluation of magneto-resistor bridge sensors.

DESIGN REVIEW: Notes On Chip Functions

iC-NQL X3		
No.	Function, Parameter/Code	Description and Application Hints
1	ZPOS Illegal settings: 0x01...0x07, 0x09...0x0F, 0x11...0x17, 0x19...0x1F	Illegal settings of ZPOS delay accurate converter operation following power on. Depending on the sin/cos input signals (phase angle) the A/B outputs can provide pulses causing an external counter to alternately count up and down. This may disturb the startup of a drive if the motion controller tolerates only single A/B edges during standstill checking. The converter operation is again accurate when the sin/cos input signals have changed, by a maximum of 45 angular degrees.
2	Pin DATA	When cycling power pin DATA may show high or low level initially. With pin TEST = low (e.g. pin open) at least a single low pulse at pin CLK is required to trigger pin DATA to show a high level after the timeout has elapsed. When continuing the clock signal after completion of data output, additional zero bits are output. With pin TEST = high (e.g. pin wired to VDD) only the timeout needs to elapse to trigger pin DATA showing high level. When continuing the clock signal after completion of data output, additional one bits are output.
3	M2S obsolete	Bits 5 to 7 of address 0x00 must be programmed to zero; period counting is not available.

Table 36: Notes on chip functions iC-NQL_X3

iC-NQL 3		
No.	Function, Parameter/Code	Description and Application Hints
1	Pin DATA	When cycling power pin DATA shows high level initially and remains on a permanent high if CRC verification does not confirm the configuration data.
3	M2S obsolete	Bits 5 to 7 of address 0x00 must be programmed to zero; period counting is not available.

Table 37: Notes on chip functions iC-NQL_3

iC-Haus expressly reserves the right to change its products and/or specifications. An info letter gives details as to any amendments and additions made to the relevant current specifications on our internet website www.ichaus.de/infoletter; this letter is generated automatically and shall be sent to registered users by email.

Copying – even as an excerpt – is only permitted with iC-Haus' approval in writing and precise reference to source.

iC-Haus does not warrant the accuracy, completeness or timeliness of the specification and does not assume liability for any errors or omissions in these materials.

The data specified is intended solely for the purpose of product description. No representations or warranties, either express or implied, of merchantability, fitness for a particular purpose or of any other nature are made hereunder with respect to information/specification or the products to which information refers and no guarantee with respect to compliance to the intended use is given. In particular, this also applies to the stated possible applications or areas of applications of the product.

iC-Haus conveys no patent, copyright, mask work right or other trade mark right to this product. iC-Haus assumes no liability for any patent and/or other trade mark rights of a third party resulting from processing or handling of the product and/or any other use of the product.

As a general rule our developments, IPs, principle circuitry and range of Integrated Circuits are suitable and specifically designed for appropriate use in technical applications, such as in devices, systems and any kind of technical equipment, in so far as they do not infringe existing patent rights. In principle the range of use is limitless in a technical sense and refers to the products listed in the inventory of goods compiled for the 2008 and following export trade statistics issued annually by the Bureau of Statistics in Wiesbaden, for example, or to any product in the product catalogue published for the 2007 and following exhibitions in Hanover (Hannover-Messe).

We understand suitable application of our published designs to be state-of-the-art technology which can no longer be classed as inventive under the stipulations of patent law. Our explicit application notes are to be treated only as mere examples of the many possible and extremely advantageous uses our products can be put to.

iC-NQL

13-bit Sin/D CONVERTER WITH SSI INTERFACE



Rev D2, Page 24/24

ORDERING INFORMATION

Type	Package	Order Designation
iC-NQL	TSSOP20 4.4 mm	iC-NQL TSSOP20

For technical support, information about prices and terms of delivery please contact:

iC-Haus GmbH
Am Kuemmerling 18
D-55294 Bodenheim
GERMANY

Tel.: +49 (61 35) 92 92-0
Fax: +49 (61 35) 92 92-192
Web: <http://www.ichaus.com>
E-Mail: sales@ichaus.com

Appointed local distributors: http://www.ichaus.com/sales_partners