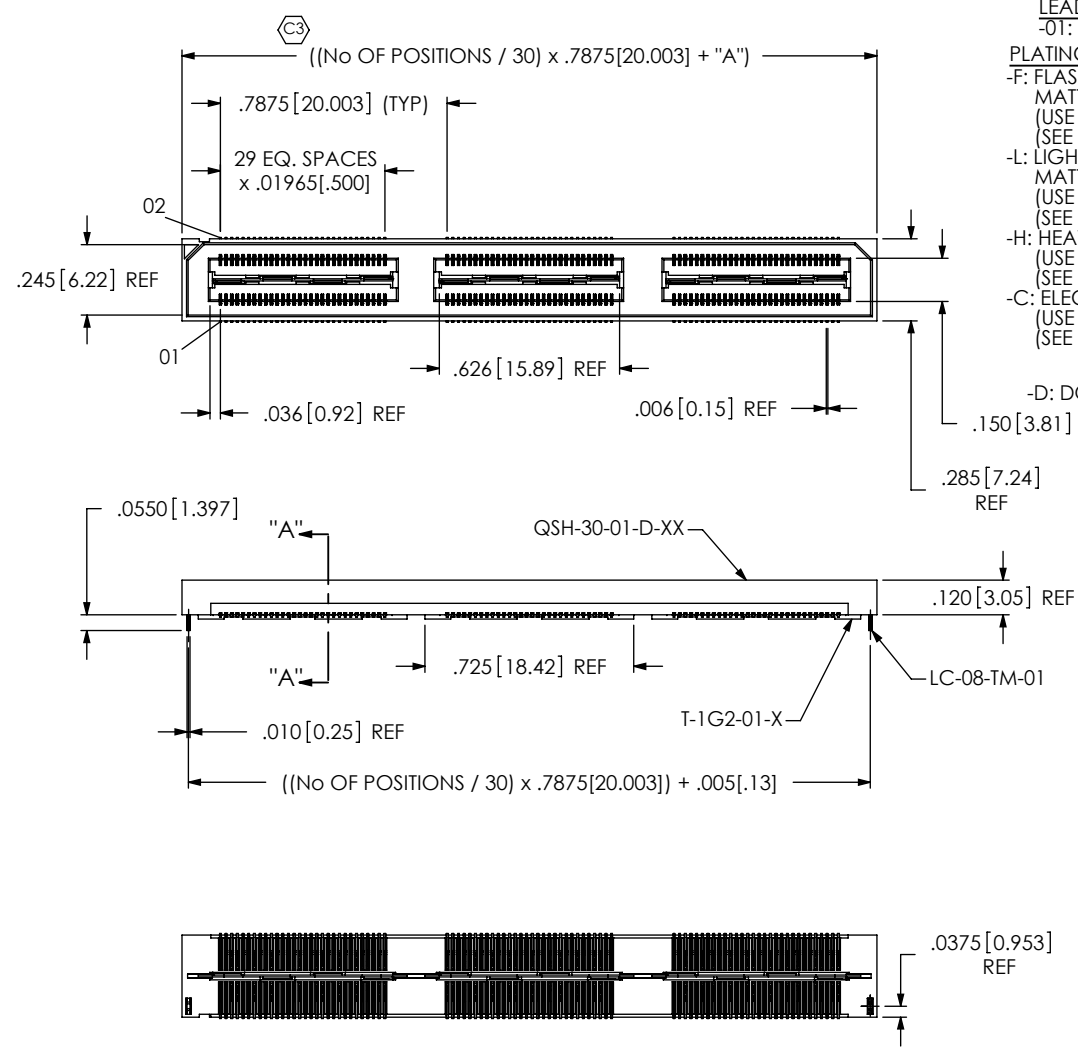

FIG. 1

-LC: LOCKING CLIP OPTION SHOWN

DO NOT SCALE FROM THIS PRINT



QSH-XXX-01-X-D-XXX

- No OF POSITIONS**
- 030, -060, -090, *-120, *-150 (PER ROW)
 - *SEE NOTE 11
- LEAD STYLE**
- 0T: .1280[3.25]
- PLATING SPECIFICATION**
- F: FLASH SELECTIVE GOLD WITH MATTE TIN TAILS (USE C-126-21-F, T-1G2-01-F) (SEE NOTE 8 & 10)
 - L: LIGHT SELECTIVE GOLD WITH MATTE TIN TAILS (USE C-126-21-L, T-1G2-01-L) (SEE NOTE 10)
 - H: HEAVY GOLD (USE C-126-21-H, T-1G2-01-G) (SEE NOTE 10)
 - C: ELECTRO-POLISHED SELECTIVE (USE C-126-21-C, T-1G2-01-L) (SEE NOTE 10)
- ROW SPECIFICATION**
- D: DOUBLE (USE QSH-30-01-D-XX)
- OPTION**
- A: ALIGNMENT PINS (USE QSH-30-01-D-XX-A, SEE FIG. 2)
 - LC: LOCKING CLIPS (USE LC-08-TM-01)
 - GP: GUIDE POSTS (USE QSH-30-01-D-XX-X-GP) (SEE FIG. 4, SHEET 3) (TAPE & REEL FOR -GP, 60 POS MAX)
 - K: POLYIMIDE FILM PAD (USE K-DOT-.325-.450-.005, SEE FIG. 3)
 - TR: TAPE & REEL (90 POS MAX)
 - FL: FRICTION LOCKS (SEE FIG. 5, SHEET 3) (NOT AVAILABLE WITH -GP)
 - RT1: RETENTION (MUST USE -A OPTION) (USE QSH-30-01-D-XX-A-RT1 & SUB-SC-05-01-FF) (SEE FIG. 6, SHEET 3) (NOT AVAILABLE WITH -LC, -GP, OR -FL)
- No OF BANKS**

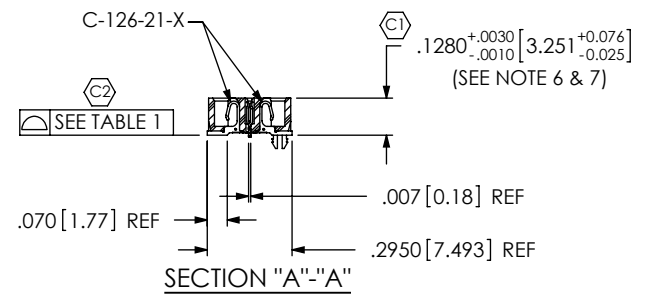

NOTES:

1. $\text{\textcircled{C}}$ REPRESENTS A CRITICAL DIMENSION.
2. NOTE DELETED.
3. CONTACT RETENTION: 8 OZ. MINIMUM.
4. GROUND PLANE RETENTION: 8 OZ. MINIMUM.
5. BURR ALLOWANCE: .0015[.038] MAX.
6. MAX VARIANCE: .002[.05].
7. DIMENSION APPLIES TO CONTACT & GROUND PLANE.
8. -L PLATING CAN BE SUBSTITUTED FOR -F PLATING, -G PLATED GROUND PLANE CAN BE SUBSTITUTED FOR -F PLATED GROUND PLANE.
9. SUB-SC-05-01-XX RETENTION TO BE 1.0 LBF IN BODY.
10. MAY SUB C-126-01 FOR C-126-21.
11. FOR NEW APPLICATIONS REQUIRING THESE POSITIONS, PLEASE CONTACT SAMTEC INTERCONNECT PROCESSING GROUP.

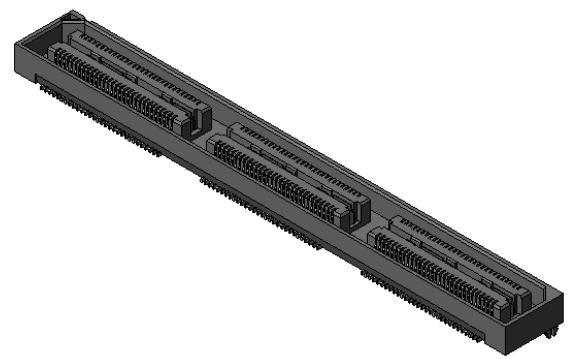

No OF POS	COPLANARITY INCLUDING GROUND PLANE
-030 THRU -060	.0040[.102]
-090 THRU -150	.0060[.152]

No OF BANKS	"A"
1-2	.0515
3-4	.0540
5	.0535

UNLESS OTHERWISE SPECIFIED, DIMENSIONS ARE IN INCHES. TOLERANCES ARE:

DECIMALS	ANGLES
.XX: $\pm .01[.3]$	2°
.XXX: $\pm .005[.13]$	
.XXXX: $\pm .0020[.051]$	

PROPRIETARY NOTE
THIS DOCUMENT CONTAINS INFORMATION CONFIDENTIAL AND PROPRIETARY TO SAMTEC, INC. AND SHALL NOT BE REPRODUCED OR TRANSFERRED TO OTHER DOCUMENTS OR DISCLOSED TO OTHERS OR USED FOR ANY PURPOSE OTHER THAN THAT WHICH IT WAS OBTAINED WITHOUT THE EXPRESSED WRITTEN CONSENT OF SAMTEC, INC.

520 PARK EAST BLVD, NEW ALBANY, IN 47150
PHONE: 812-944-6733 FAX: 812-948-5047
e-Mail: info@SAMTEC.com code: 55322

MATERIAL:	DO NOT SCALE DRAWING	SHEET SCALE: 1.5:1	DESCRIPTION:
INSULATOR: BLACK LCP			.5mm DOUBLE ROW HS SOCKET ASSEMBLY
CONTACT & GROUND PLANE: PHOS BRONZE			DWG. NO.
			QSH-XXX-01-X-D-XXX
			BY: DEAN P 05/21/1999
			SHEET 1 OF 3

FIG. 2
-A: ALIGNMENT PIN OPTION

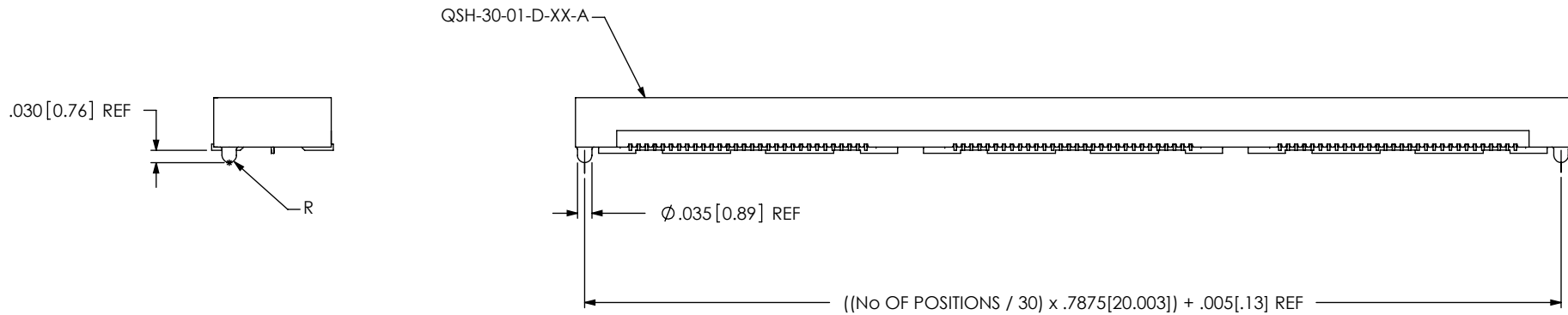
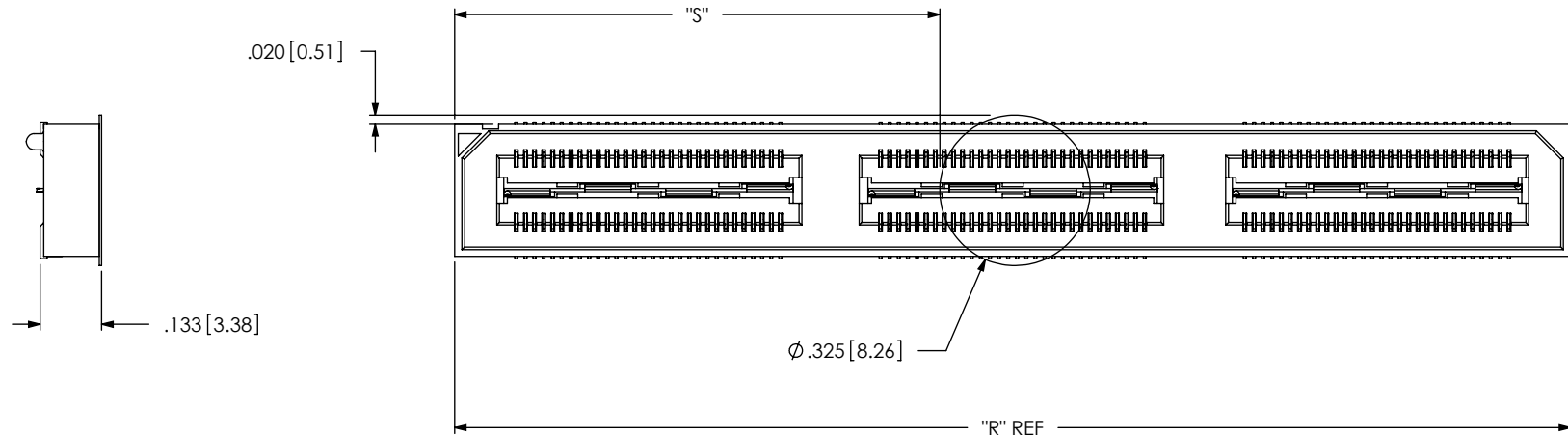

FIG. 3
-K: POLYIMIDE FILM PAD
[USE K-DOT-.325-.450-.005]



NOTE: "R" = ((No OF POSITIONS / 30) x .7875[20.003]) + .050[1.27]
 WITH -RT1 OPTION: "R" = ((No OF POSITIONS / 30) x .7875[20.003]) + .650[16.51] REF
 WITH -GP OPTION: "R" = ((No OF POSITIONS / 30) x .7875[20.003]) + .4285[10.884] REF
 "S" = (("R" - .325[8.26]) / 2) ± .020[.51]

<p>PROPRIETARY NOTE</p> <p>THIS DOCUMENT CONTAINS INFORMATION CONFIDENTIAL AND PROPRIETARY TO SAMTEC, INC. AND SHALL NOT BE REPRODUCED OR TRANSFERRED TO OTHER DOCUMENTS OR DISCLOSED TO OTHERS OR USED FOR ANY PURPOSE OTHER THAN THAT WHICH IT WAS OBTAINED WITHOUT THE EXPRESSED WRITTEN CONSENT OF SAMTEC, INC.</p> <p>DO NOT SCALE DRAWING</p> <p>SHEET SCALE: 2.5:1</p>		
	<p>520 PARK EAST BLVD, NEW ALBANY, IN 47150 PHONE: 812-944-6733 FAX: 812-948-5047 e-Mail: info@SAMTEC.com code: 55322</p>	
	<p>DESCRIPTION: .5mm DOUBLE ROW HS SOCKET ASSEMBLY</p>	
	<p>DWG. NO. QSH-XXX-01-X-D-XXX</p>	
<p>BY: DEAN P 05/21/1999</p>		<p>SHEET 2 OF 3</p>

FIG. 4

-GP: GUIDE POSTS
(SAME AS FIG. 1, UNLESS OTHERWISE STATED)

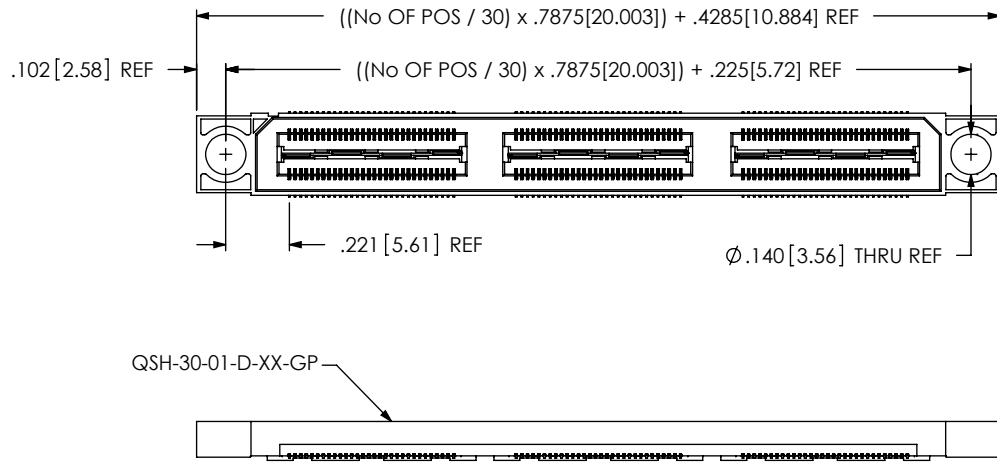

FIG. 5

-FL: FRICTION LOCKS
(NOT AVAILABLE WITH -GP OPTION)
(SAME AS FIG. 1, UNLESS OTHERWISE STATED)

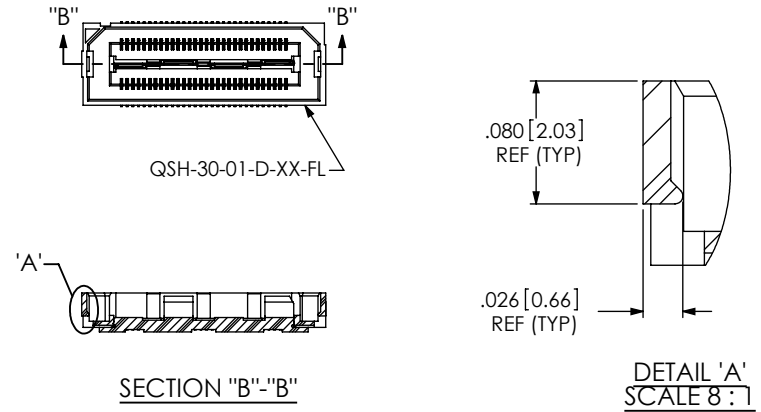
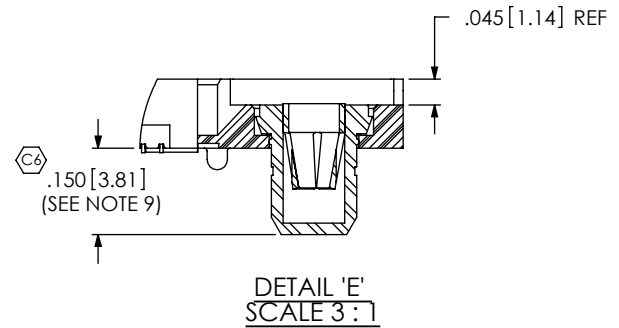
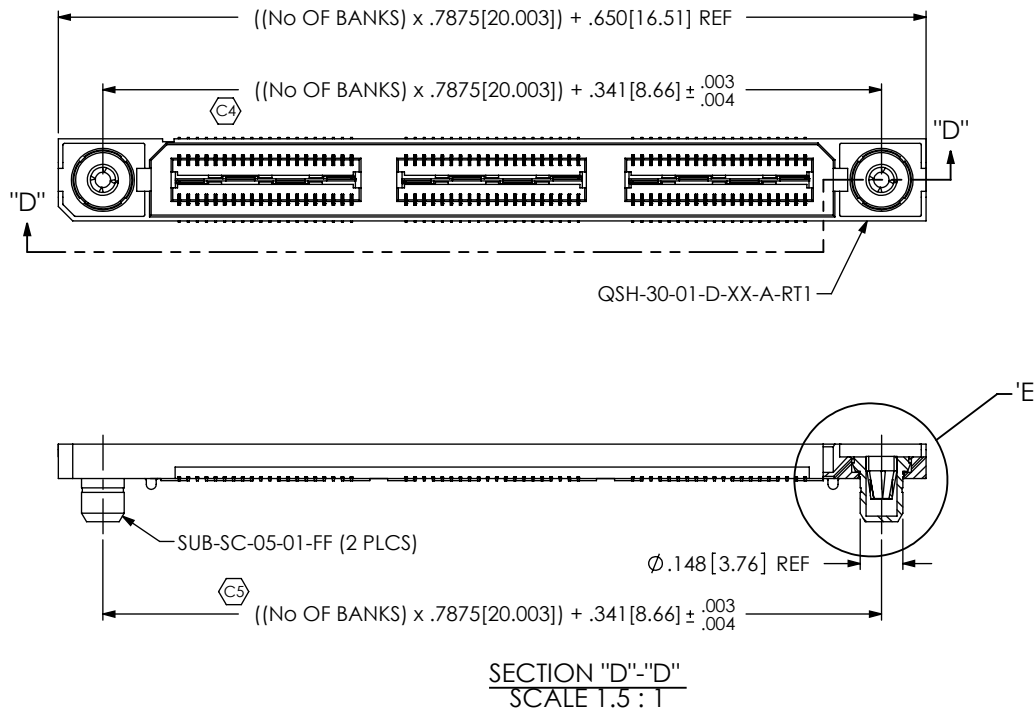

FIG. 6

-RT1: RETENTION OPTION
(MUST USE -A OPTION)
(NOT AVAILABLE WITH -LC, -GP, OR -FL OPTIONS)
(NOT AVAILABLE WITH -120 & -150 POS)
(SAME AS FIG. 1, UNLESS OTHERWISE STATED)



PROPRIETARY NOTE

THIS DOCUMENT CONTAINS INFORMATION CONFIDENTIAL AND PROPRIETARY TO SAMTEC, INC. AND SHALL NOT BE REPRODUCED OR TRANSFERRED TO OTHER DOCUMENTS OR DISCLOSED TO OTHERS OR USED FOR ANY PURPOSE OTHER THAN THAT WHICH IT WAS OBTAINED WITHOUT THE EXPRESSED WRITTEN CONSENT OF SAMTEC, INC.

DO NOT SCALE DRAWING

SHEET SCALE: 1.5:1

samtec

520 PARK EAST BLVD, NEW ALBANY, IN 47150
PHONE: 812-944-6733 FAX: 812-948-5047
e-Mail: info@SAMTEC.com code: 55322

DESCRIPTION:
.5mm DOUBLE ROW HS SOCKET ASSEMBLY

DWG. NO.
QSH-XXX-01-X-D-XXX

BY: DEAN P 05/21/1999 SHEET 3 OF 3