

# Customer Information Sheet

DRAWING No.: S8211-46R

SHEET 2 OF 2

IF IN DOUBT - ASK

©

NOT TO SCALE

THIRD ANGLE PROJECTION

ALL DIMENSIONS IN mm

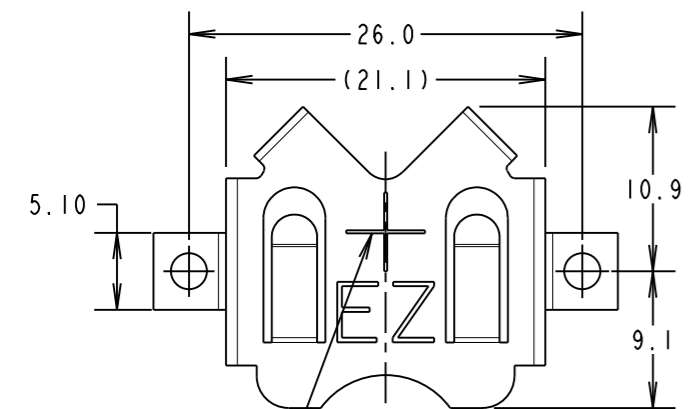
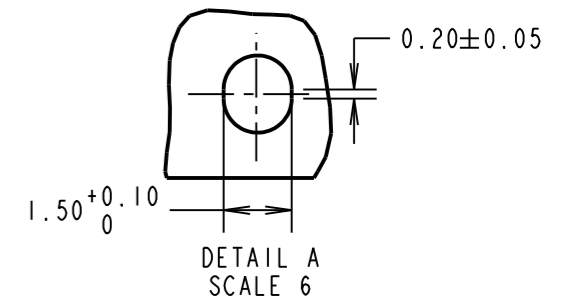
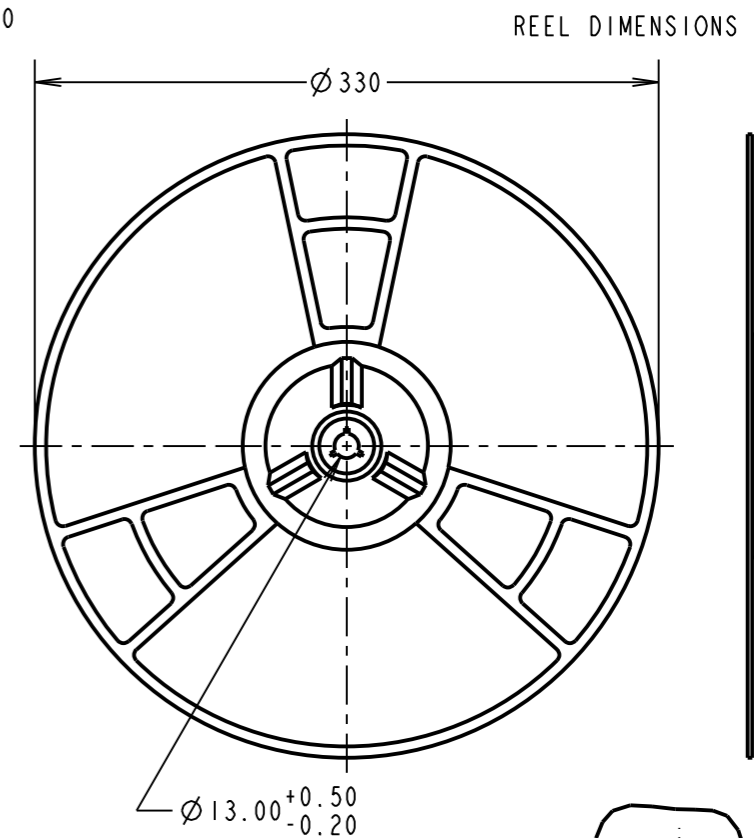
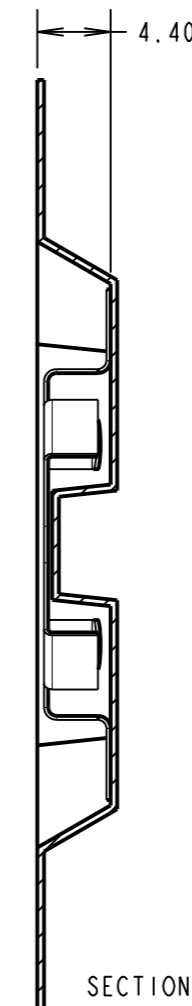
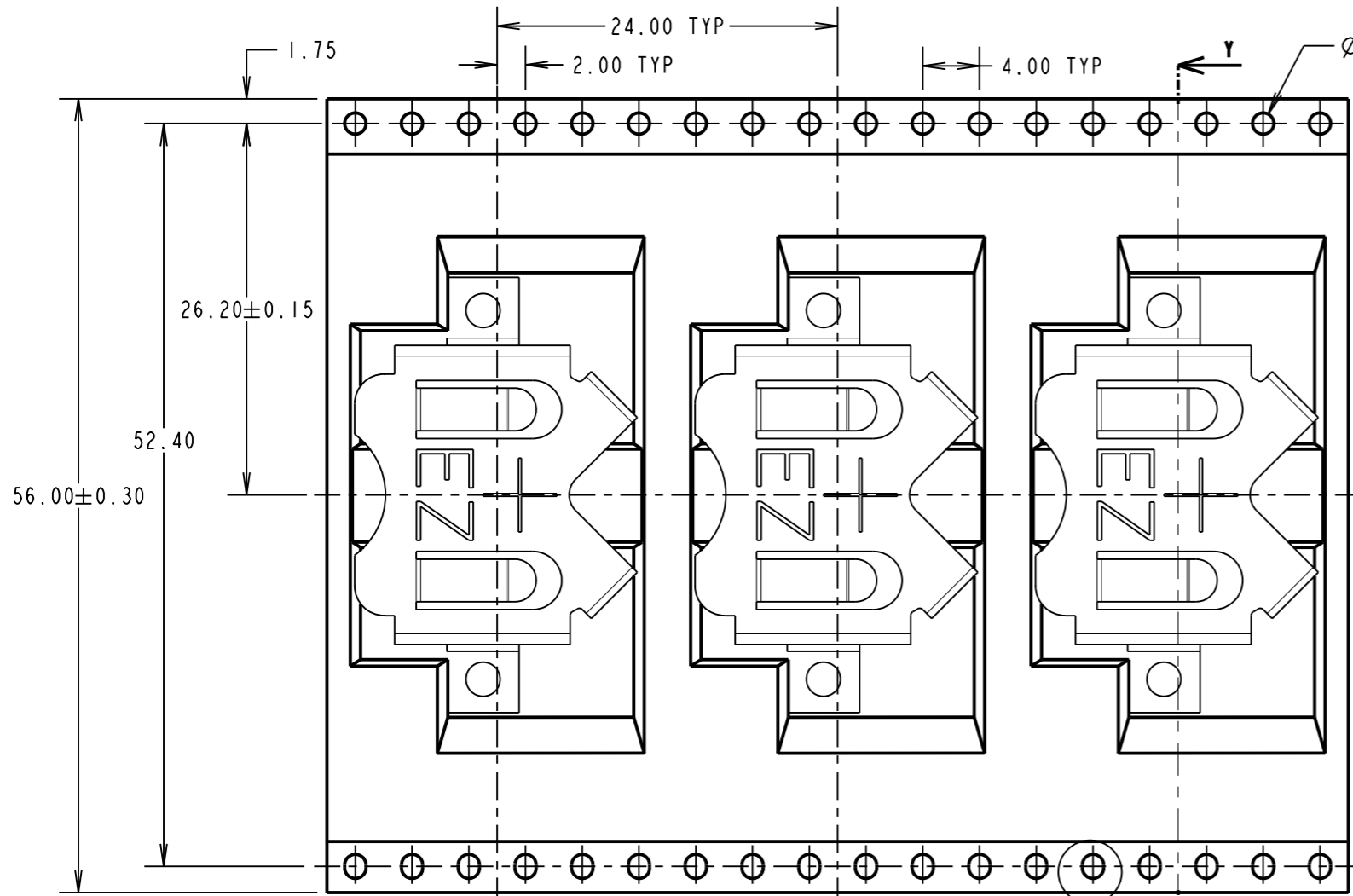

SEE DETAIL A  
RECOMMENDED PAD LAYOUT

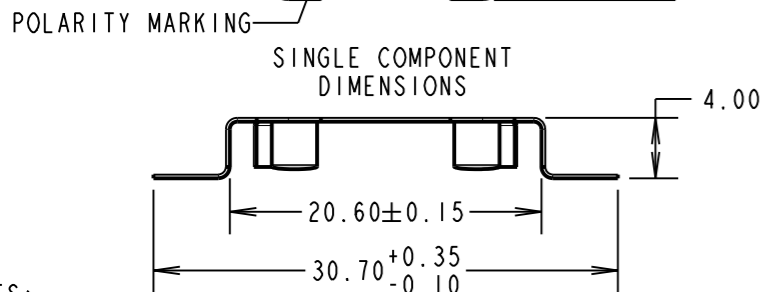
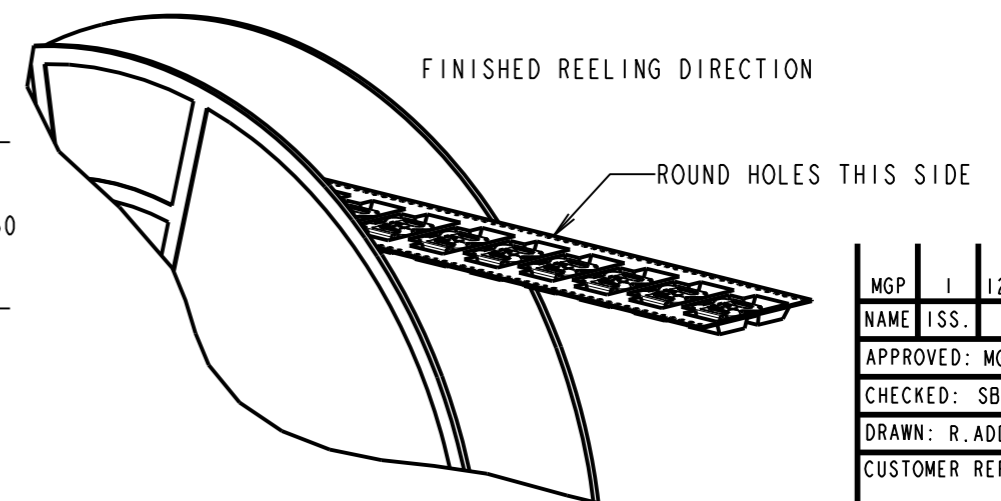
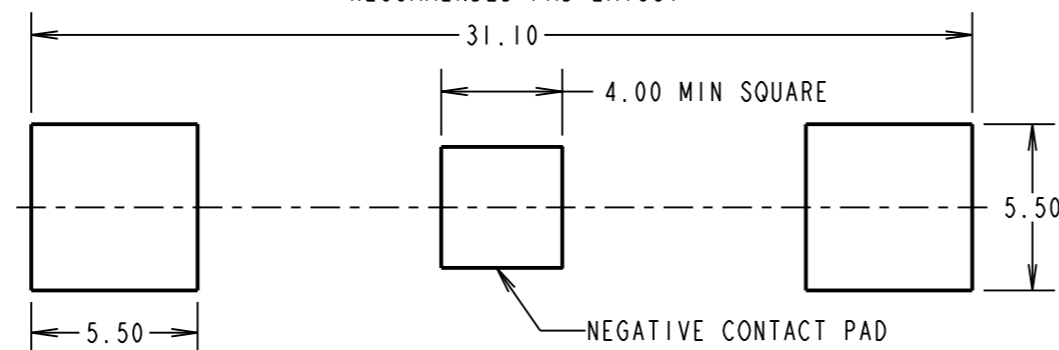

SPECIFICATION:  
MATERIAL = PHOSPHOR BRONZE  
FINISH:  
46 = 3µ 100% TIN, OVER NICKEL  
FOR COMPONENT SPECIFICATION SEE C043XX,  
(LATEST ISSUE)

MGP	1	12.03.12	11680
NAME	ISS.	DATE	C/NOTE
APPROVED: MGP			
CHECKED: SB			
DRAWN: R.ADDE			
CUSTOMER REF.:			
ASSEMBLY DRG:			

- NOTES:
1. QUANTITY PER REEL = 550.
  2. THIS PRODUCT IS TAPED AND REELED IN ACCORDANCE WITH EIA-481-2-A (ELECTRONIC INDUSTRIES ASSOCIATION).
  3. THIS PRODUCT IS SUITABLE FOR THE FOLLOWING BATTERIES: CR2016, CR2025, CR2032 & BR2016, BR2020, BR2025 & OTHERS PLEASE CHECK MANUFACTURERS SPECIFICATIONS FOR SUITABILITY.

**HARWIN**

www.harwin.com  
technical@harwin.com

THIS DRAWING AND ANY INFORMATION OR DESCRIPTIVE MATTER SET OUT HEREON ARE CONFIDENTIAL AND COPYRIGHT PROPERTY OF THE HARWIN GROUP AND MUST NOT BE DISCLOSED, LOANED, COPIED OR USED FOR MANUFACTURING, TENDERING OR FOR ANY OTHER PURPOSE WITHOUT THEIR WRITTEN PERMISSION.

TOLERANCES  
X. = ±1mm  
X.X = ±0.25mm  
X.XX = ±0.10mm  
X.XXX = ±0.01mm  
ANGLES = ±5°  
UNLESS STATED

MATERIAL: SEE ABOVE  
FINISH: SEE ABOVE  
S/AREA: mm<sup>2</sup>

TITLE:  
COIN CELL RETAINER (20mm)  
(TAPE & REELED)

DRAWING NUMBER:  
**S8211-46R**

SHT  
2 OF 2