

# LCD Module Technical Specification

First Edition  
May. 02, 2007

Final Revision  
Apr. 10, 2012

Type No. **T-51750GD065J-FW-ADN**

Customer : **STANDARD**

Customer's Product No : -----

## KYOCERA Display Corporation

Approved: *Toshiyuki Okamoto*  
QUALITY ASSURANCE DIVISION

Checked: *Masayuki Kato*  
Design Div.

Prepared: *Hironori Miyano*  
Design Div.

## Table of Contents

1. General Specifications.....	3
2. Electrical specifications .....	4
3. Optical Specifications .....	12
4. I/O Terminal.....	17
5. Test .....	19
6. Appearance Standards.....	20
7. Code System of Production Lot .....	23
8. Type Number.....	23
9. Applying Precautions.....	23
10. Precautions Relating Product Handling.....	24
11. Warranty.....	26

## Revision History

Rev.	Date	Page	Comment
1	May. 09, 2008	24~26	Revise of Precautions Relating Product Handling and Warranty.
2	Apr. 10. 2012	-	Changing company's name

## 1. General Specifications

Operating Temperature	: min. -25 deg. to max. 75 deg. (*Note)
Storage Temperature	: min. -25 deg. to max. 85 deg.
Resolution	: 640 x 3 [R.G.B] (W) x 480 (H) dots
Dot pitch	: 0.069 x 3 [R.G.B] (W) x 0.207 (V) mm
Pixel arrangement	: RGB-Stripe
Color depth	: 262,144 colors
Active Viewing Area	: 132.5 (W) x 99.4 (H) mm
Outline dimensions *	: 158.0 (W) x 120.36 (H) x 10.75 (D) mm * Excluding backlight cables.
Weight	: 190 g typ.
LCD type	: Normally white-mode / Transmissive
Viewing angle	: 6:00
Interface	: 18-bit parallel data transfer (6-bit / color)
Backlight *	: CCFL, Edge lighting type 2-tubes, replaceable <u>* Backlight driving DC/AC inverter is not built in this module.</u>
Surface Treatment	: AG Coating
Appendix	: Method of replacing the lamp unit : UL LABEL
Drawings	: Dimensional Outline UE-313014C
RoHS regulation	: To our best knowledge, this product satisfies material requirement of RoHS regulation. Our company is doing the best efforts to obtain the equivalent certificate from our suppliers.

Note : Operation temperature range defines the operation only.  
Electrical and optical specification can be guaranteed at the condition that ambient temperature is 25°C.

## 2. Electrical specifications

### 2.1. Absolute Maximum Ratings

Parameter	Symbol	Conditions	Min.	Max.	Unit
Supply Voltage for LCD	VCC	-	0	5.5	V
Logic Input Voltage	VI	-	0	5.5	V

### 2.2. DC characteristics

#### (1) TFT-LCD

Ambient Temperature : Ta = 25°C

ITEM	SYMBOL	MIN.	TYP.	MAX.	UNIT	Remarks
Power Supply Voltages for LCD Note A)	VCC	3.0	3.3	3.6	V	for 3.3V system
		4.5	5.0	5.5	V	for 5V system
Power Supply Currents for LCD Note B)	ICC	--	240	--	mA	for 3.3V system
		--	180	--	mA	for 5V system
Permissive input ripple Voltage	VRP	--	--	100	mVp-p	VCC=+3.3V
		--	--	100	mVp-p	VCC=+5.0V
Logic Input Voltage	High	VIH	2.4	--	V	VCC=MAX
	Low	VIL	0	--	0.8	V

[Note]

#### A) VCC-dip conditions:

- 1) When  $2.4\text{ V} \leq VCC < 3.0\text{ V}$  or  $4.5\text{V}$ ,  $t_d \leq 10\text{ ms}$
- 2) When  $VCC < 2.4\text{ V}$

VCC-dip conditions should also follow the power and signals sequence.

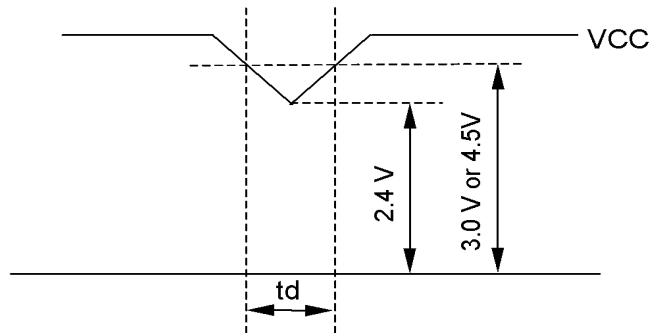

#### B) Typical current condition:

64- gray- bar-pattern

480 line mode

VCC = +3.3 V,  $f_H=31.5\text{kHz}$ ,  $f_V=60\text{Hz}$ ,  $f_{CLK}= 25\text{MHz}$

VCC = +5.0 V,  $f_H=31.5\text{kHz}$ ,  $f_V=60\text{Hz}$ ,  $f_{CLK}= 25\text{MHz}$

### 2.3. AC Characteristic

ITEM		SYMBOL	MIN.	TYP.	MAX.	UNIT
DCLK	Frequency	$f_{CLK}$	20	25	30	MHz
	Period	$t_{CLK}$	33.3	40	50	ns
	Low Width	$t_{WCL}$	10	--	--	ns
	High Width	$t_{WCH}$	10	--	--	ns
DATA (R,G,B,DENA, HD, VD)	Set up time	$t_{DS}$	5	--	--	ns
	Hold time	$t_{DH}$	5	--	--	ns
DENA	Horizontal Active Time	$t_{HA}$	640	640	640	$t_{CLK}$
	Horizontal Front Porch	$t_{HFP}$	0	--	--	$t_{CLK}$
	Horizontal Back Porch	$t_{HBP}$	7	--	--	$t_{CLK}$
	Vertical Active Time	$t_{VA}$	480	480	480	$t_H$
	Vertical Front Porch	$t_{VFP}$	1	20	--	$t_H$
	Vertical Back Porch	$t_{VBP}$	8	20	--	$t_H$
HD	Frequency	$f_H$	27	31.5	38	kHz
	Period	$t_H$	26.3	31.7	37.0	$\mu s$
	Low Width	$t_{WHL}$	5	--	--	$t_{CLK}$
VD	Frequency	$f_V$	55	60	70	Hz
	Period	$t_V$	14.3	16.7	18.2	ms
	Low Width	$t_{WVL}$	3	--	--	$t_H$

[Note]

- 1) DATA is latched at fall edge of DCLK in this timing specification.
- 2) Polarities of HD and VD are negative in this specification.
- 3) DENA (Data Enable) should always be positive polarity as shown in the timing specification.
- 4) DCLK should appear during all invalid period, and HD should appear during invalid period of frame cycle.
- 5) Accepted only 640 data and 480 lines.
- 6) REV should be stable during operation.

7) Please consider the influence of the filter circuit which is placed in the Signal Input, DCLK and Data Bus, when designing the circuit. AC Characteristic spec is based on ideal signal driving.

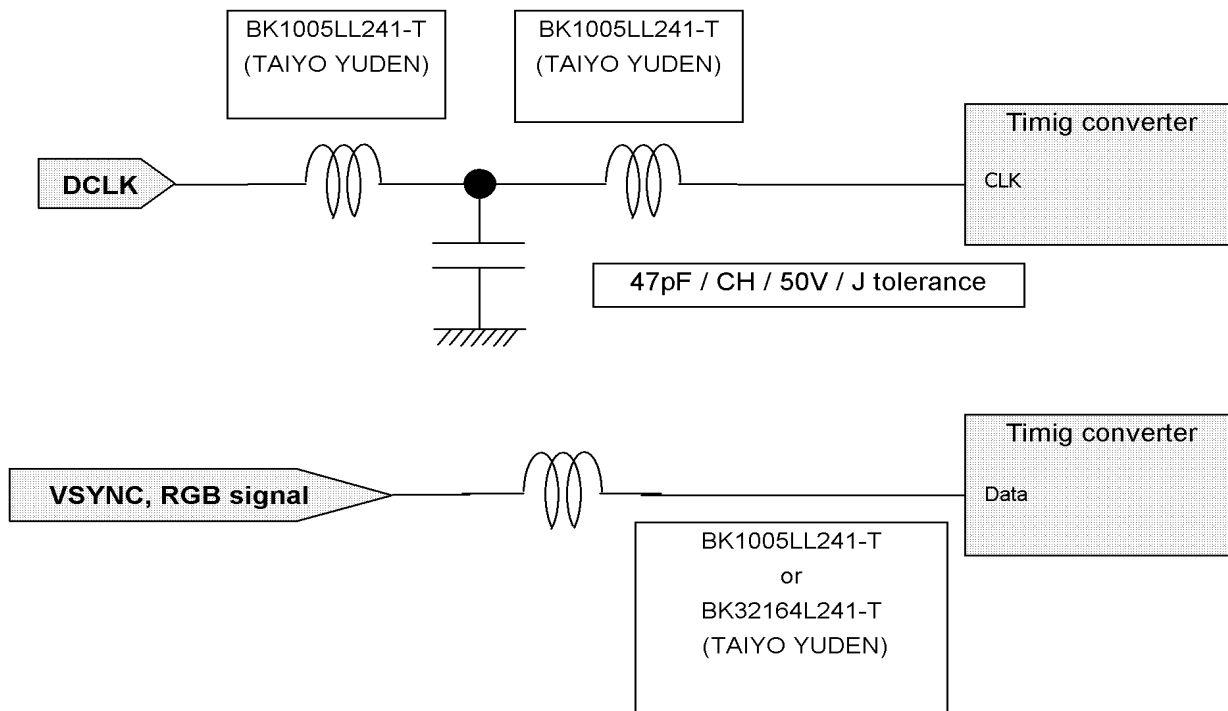

## 2.4. Timing Chart

### a. Pixel Timing Chart

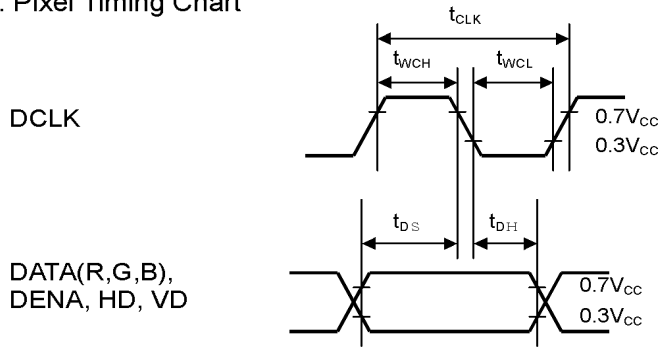

### b. Horizontal Timing Chart

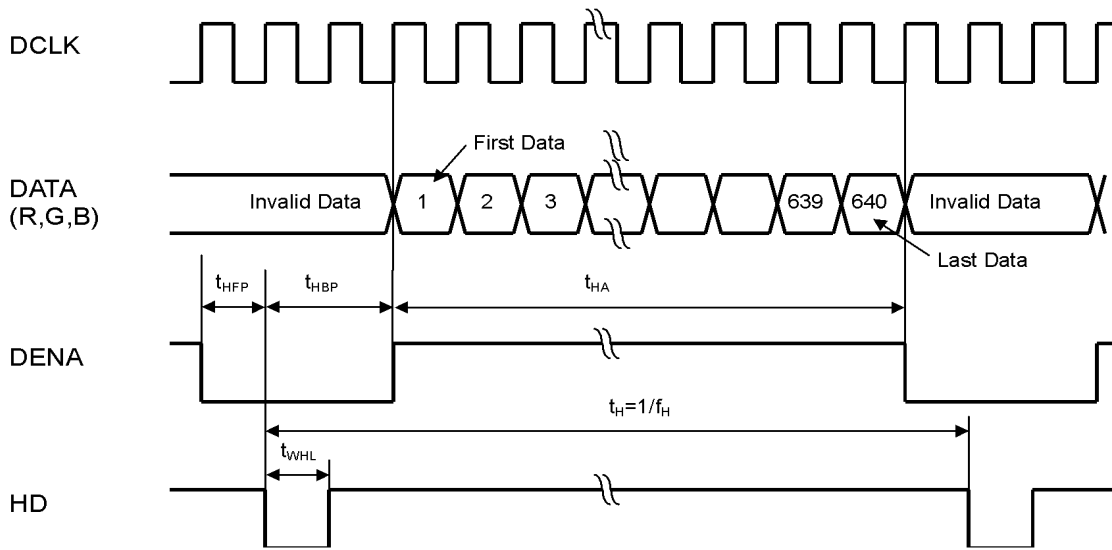

### c. Vertical Timing Chart

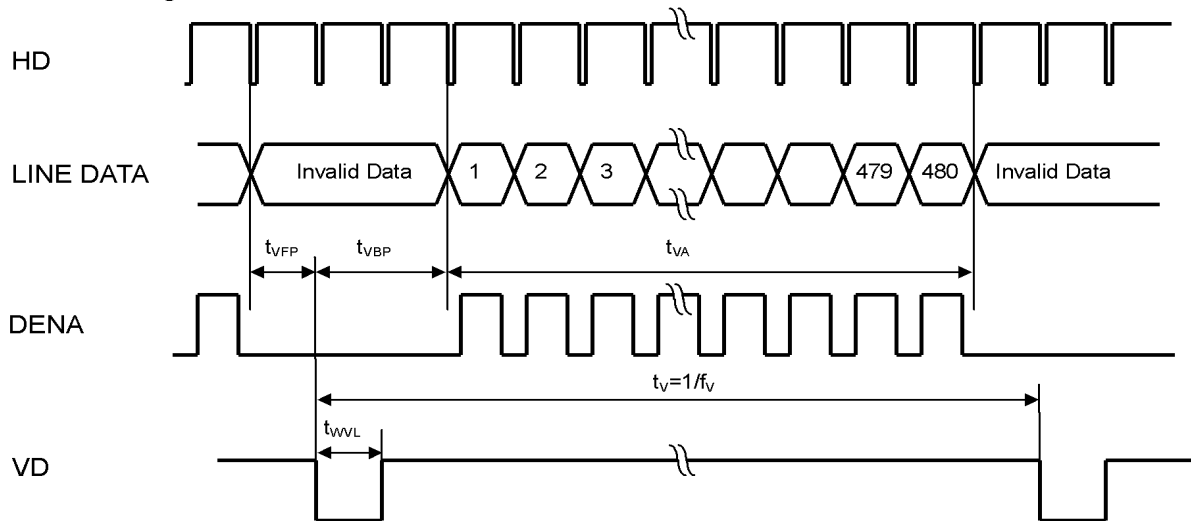

2.5. Power and signals sequence:

$$t1 \leq 10 \text{ ms} \quad 200 \text{ ms} < t6$$

$$0 < t2 \leq 50 \text{ ms} \quad 0 \leq t7$$

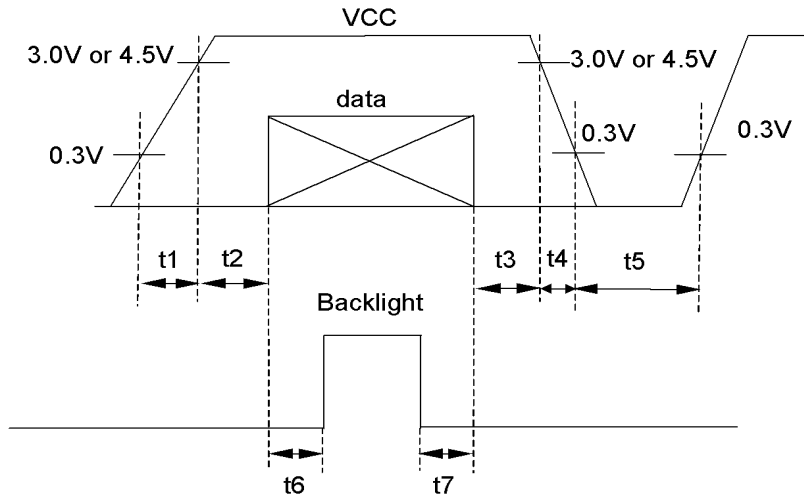

data: RGB DATA, DCLK, HD, VD, DENA

$$0 < t3 \leq 50 \text{ ms}$$

$$0 < t4 \leq 50 \text{ ms}$$

$$500 \text{ ms} < t5$$

2.6. Pixel Alignment

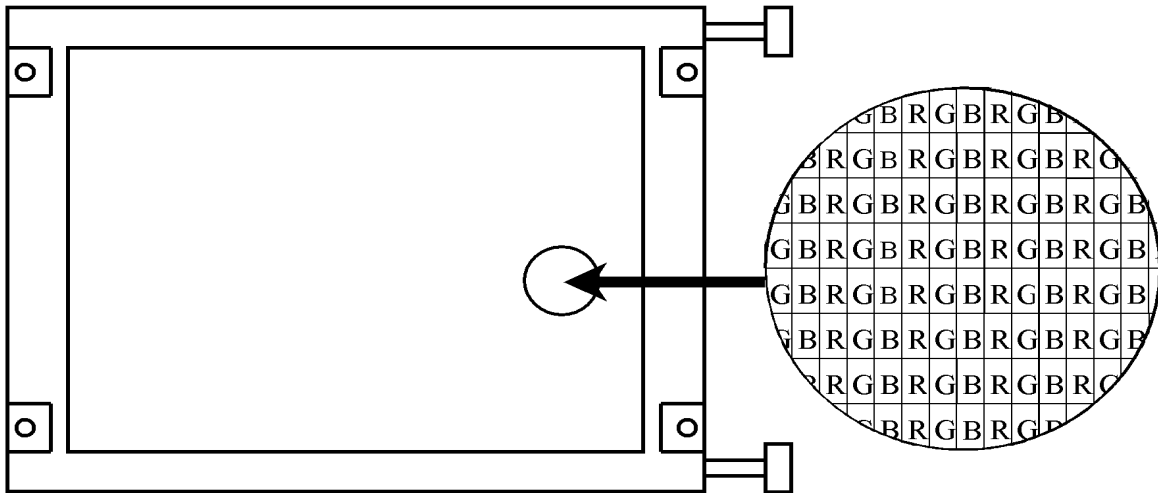



## 2.7. Color Data Assignment

COLOR	INPUT DATA	R DATA						G DATA						B DATA					
		MSB			LSB			MSB			LSB			MSB			LSB		
		R5	R4	R3	R2	R1	R0	G5	G4	G3	G2	G1	G0	B5	B4	B3	B2	B1	B0
BASIC COLOR	BLACK	0	0	0	0	0	0	0	0	0	0	0	0	0	0	0	0	0	0
	RED (63)	1	1	1	1	1	1	0	0	0	0	0	0	0	0	0	0	0	0
	GREEN (63)	0	0	0	0	0	0	1	1	1	1	1	1	0	0	0	0	0	0
	BLUE (63)	0	0	0	0	0	0	0	0	0	0	0	0	1	1	1	1	1	1
	CYAN	0	0	0	0	0	0	1	1	1	1	1	1	1	1	1	1	1	1
	MAGENTA	1	1	1	1	1	1	0	0	0	0	0	0	1	1	1	1	1	1
	YELLOW	1	1	1	1	1	1	1	1	1	1	1	1	0	0	0	0	0	0
	WHITE	1	1	1	1	1	1	1	1	1	1	1	1	1	1	1	1	1	1
RED	RED (0)	0	0	0	0	0	0	0	0	0	0	0	0	0	0	0	0	0	0
	RED (1)	0	0	0	0	0	1	0	0	0	0	0	0	0	0	0	0	0	0
	RED (2)	0	0	0	0	1	0	0	0	0	0	0	0	0	0	0	0	0	0
	RED (62)	1	1	1	1	1	0	0	0	0	0	0	0	0	0	0	0	0	0
	RED (63)	1	1	1	1	1	1	0	0	0	0	0	0	0	0	0	0	0	0
GREEN	GREEN (0)	0	0	0	0	0	0	0	0	0	0	0	0	0	0	0	0	0	0
	GREEN (1)	0	0	0	0	0	0	0	0	0	0	0	1	0	0	0	0	0	0
	GREEN (2)	0	0	0	0	0	0	0	0	0	0	1	0	0	0	0	0	0	0
	GREEN (62)	0	0	0	0	0	0	1	1	1	1	1	0	0	0	0	0	0	0
	GREEN (63)	0	0	0	0	0	0	1	1	1	1	1	1	0	0	0	0	0	0
BLUE	BLUE (0)	0	0	0	0	0	0	0	0	0	0	0	0	0	0	0	0	0	0
	BLUE (1)	0	0	0	0	0	0	0	0	0	0	0	0	0	0	0	0	0	1
	BLUE (2)	0	0	0	0	0	0	0	0	0	0	0	0	0	0	0	0	1	0
	BLUE (62)	0	0	0	0	0	0	0	0	0	0	0	0	1	1	1	1	1	0
	BLUE (63)	0	0	0	0	0	0	0	0	0	0	0	0	1	1	1	1	1	1

[Note]

1) Definition of gray scale

Color (n) --- n indicates gray scale level.

Higher n means brighter level.

2) Data 1:High, 0: Low

## 2.8. Inverted Scan Capability

This module has the capability of inverting scan direction by signaling from controller.

Note that scan direction cannot be changed during operation.

The following figure shows the relation between the display position and the scan direction.

### DISPLAY POSITION

Normal scan: REV = "L"

D( 1, 1)	D( 2, 1)	---	D( X, 1)	---	D(639, 1)	D(640, 1)
D( 1, 2)	D( 2, 2)	---	D( X, 2)	---	D(639, 2)	D(640, 2)
		+	+	+		
D( 1, Y)	D( 2, Y)	---	D( X, Y)	---	D(639, Y)	D(640, Y)
		+	+	+		
D( 1,479)	D( 2,479)	---	D( X,479)	---	D(639,479)	D(640,479)
D( 1,480)	D( 2,480)	---	D( X,480)	---	D(639,480)	D(640,480)

Reverse scan: REV = "H"

D(640,480)	D(639,480)	---	D( X,480)	---	D( 2,480)	D( 1,480)
D(640,479)	D(639,479)	---	D( X,479)	---	D( 2,479)	D( 1,479)
		+	+	+		
D(640, Y)	D(639, Y)	---	D( X, Y)	---	D( 2, Y)	D( 1, Y)
		+	+	+		
D(640, 2)	D(639, 2)	---	D( X, 2)	---	D( 2, 2)	D( 1, 2)
D(640, 1)	D(639, 1)	---	D( X, 1)	---	D( 2, 1)	D( 1, 1)

The following drawing shows the relationship between the viewing direction and the scan direction.

Normal scan

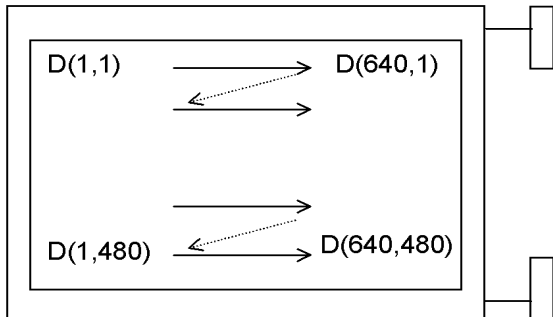

Reverse scan

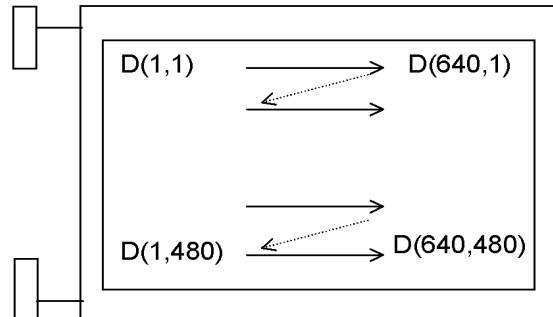

## 2.9. Lighting Specifications

Ta=25°C

Parameter	Symbol	Conditions	Min.	Typ.	Max.	Units	Notes
Lamp Voltage	V <sub>L</sub>	-	-	320	-	Vrms	1
Lamp Current	I <sub>L</sub>	-	-	6.0	7.0	mArms	2
Starting Voltage	V <sub>s</sub>	-	-	-	520	Vrms	3
Surface Luminance	L	I <sub>L</sub> =6mA	-	4500	-	cd/m <sup>2</sup>	4
Average Life	T <sub>AL</sub>	I <sub>L</sub> =6mA	50,000	-	-	hrs	5

Note 1 : The voltage ( r.m.s. ) to maintain the electric discharge of the lamp. It is measured after lighting for 3 minutes .

Note 2 : The current ( r.m.s. ) to flow through the lamp with the electric discharge. It is measured after lighting for 3 minutes.

Note 3 : The voltage at starting the electric discharge when the voltage is increased gradually from 0V.

Note 4 : Surface Luminance is specified by the average of 9 luminance values measured at each point shown above after 20 minutes power on with the all ON pattern adjusted to maximum contrast and the dimming control of 100%. ( maximum brightness )

Note 5 : CFL Life is defined as time period that the actual luminance becomes 50% or lower of its initial value.

The Average life time of CFL is defined as the time when half or more of the testing CFLs have become less bright than 50% of the initial brightness at continuous operation.

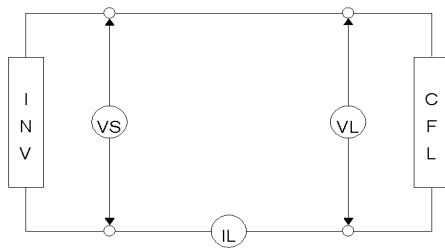

CFL Testing Circuit

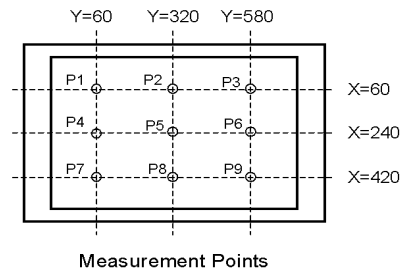

Measurement Points

Recommended Inverter : S-12645 ( Produced by ELEVAM )

### 3. Optical Specifications

Item	Symbol	Conditions			Standard Value			Unit	Method of Measure	Remark
		$\theta$	$\phi$	C	Min.	Typ.	Max.			
Brightness	B	0°	0°	/	-	400	-	cd/m <sup>2</sup>	(Fig.3-1)	Note3-1
Contrast	CR	Best Viewing			150	300	-	-		
Color Coordinates	Red	Rx	0°	0°	/	-	0.56	-		
		Ry	0°	0°	/	-	0.33	-		
	Green	Gx	0°	0°	/	-	0.34	-		
		Gy	0°	0°	/	-	0.53	-		
	Blue	Bx	0°	0°	/	-	0.15	-		
		By	0°	0°	/	-	0.14	-		
White	Wx	0°	0°	/	-	0.32	-			
	Wy	0°	0°	/	-	0.32	-			
Brightness Uniformity	-	0°	0°	/	0.7	-	-	-	(Fig.3-2)	
Vertical Viewing Angle	Up	$\theta_U$	-	0°	$\geq 10$	-	30	-	Degree	(Fig.3-3)
	Down	$\theta_D$	-	0°	$\geq 10$	-	60	-	Degree	
Horizontal Viewing Angle	Left	$\phi_L$	0°	-	$\geq 10$	-	55	-	Degree	
	Right	$\phi_R$	0°	-	$\geq 10$	-	55	-	Degree	
Response Time	Rise	$\tau_r$	0°	0°	/	-	15	-	ms	(Fig.3-4)
	Decay	$\tau_d$	0°	0°	/	-	16	-	ms	
Haze	H	/			-	9	-	%		

Note3-1: Under the condition of maximum brightness.

- ◆ Conditions for Measuring
  - ◇ Environment: Dark room with no light or close to no light.
  - ◇ Temperature: 25±5°C
  - ◇ Humidity: 40~70%RH
  - ◇ After backlight has been lit more than 30 minutes, driving voltage is set for optimal contrast to measure center of display.
  - ◇ Measure by the specified inverter or similar product.  
Condition: IL=6.0 mA, FL=58 kHz
- ◆ Optimal viewing angle (The angle with best contrast)

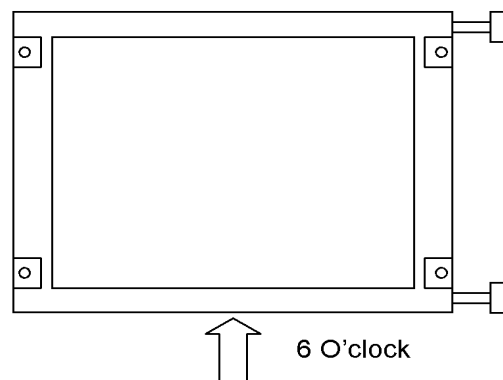

(Fig.3-1)

◆ Method of Brightness Measurement

(1) Measuring Device

TOPCON BM-7, Measuring Field: 1°

(2) Measuring Point

Center of Display  $\theta=0^\circ, \phi=0^\circ$

On condition  $\theta$ : A vertical angle from measuring direction to perpendicular.

$\phi$ : A horizontal angle from measuring direction to perpendicular.

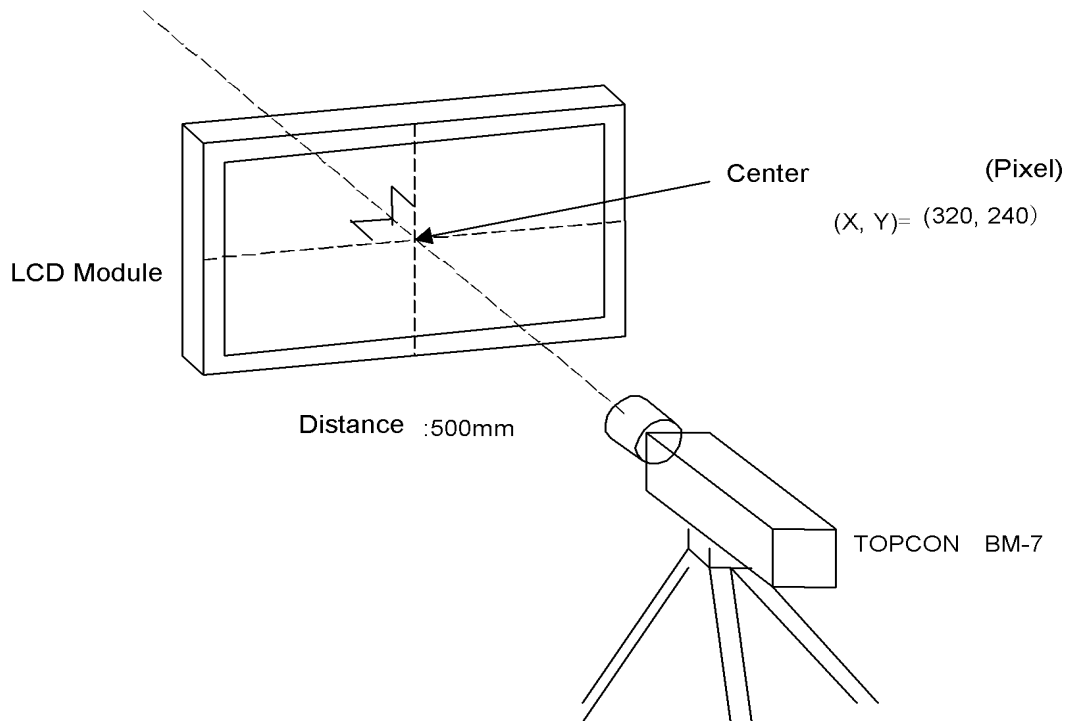

(3) Method of Measuring

Apply signal voltage (displayed in white) to maximize brightness and measure brightness B ( $\text{cd}/\text{m}^2$ ).

The distance between BM-7's front lens to surface panel is 500mm.

Measured after backlight has been lit for more than 30 minutes.

◆ Method of Contrast Measurement

(1) Measuring Device

TOPCON BM-7, Measuring Field: 1°

(2) Measuring Point

Center of display: same as Method of Brightness Measurement

(3) Method of Measuring

• Set LCD module to  $\theta=0^\circ, \phi=0^\circ$ .

• Change signal voltage to measure maximum brightness Y1 and minimum brightness Y2.

• Contrast is derived from  $\text{CR}=\text{Y1}/\text{Y2}$ .

(Fig.3-2)

◆ Definition of Brightness Uniformity

Definition is calculated from the 5 points (S0-S4) on the diagram below.

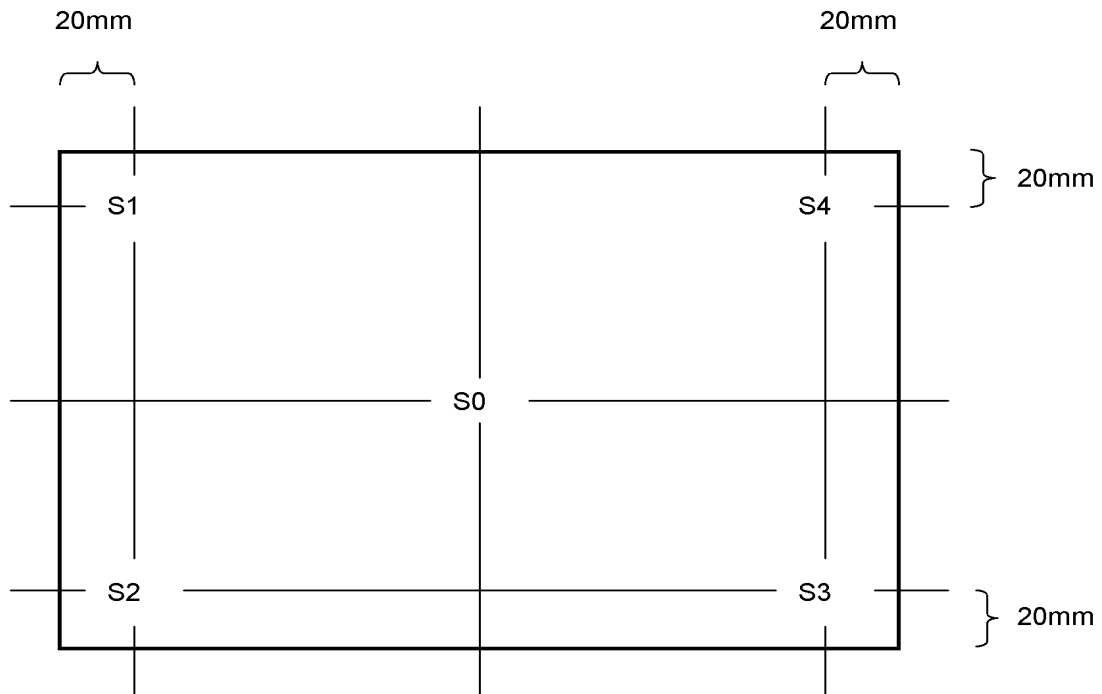

$$\text{Standard Value of Brightness Uniformity} = \frac{\text{Minimum Value of S1-S4}}{S0}$$

(Fig.3-3)

◆ Method of Viewing Angle Measurement

(1) Measuring Device

TOPCON BM-7, Measuring Field:  $1^\circ$

(2) Measuring Point

Center of display : Same as Method of Brightness Measurement

(3) Angle of Measuring

$\theta$ : An angle vertical to perpendicular line from the viewing direction.

$\phi$ : An angle horizontal to perpendicular from the viewing direction.

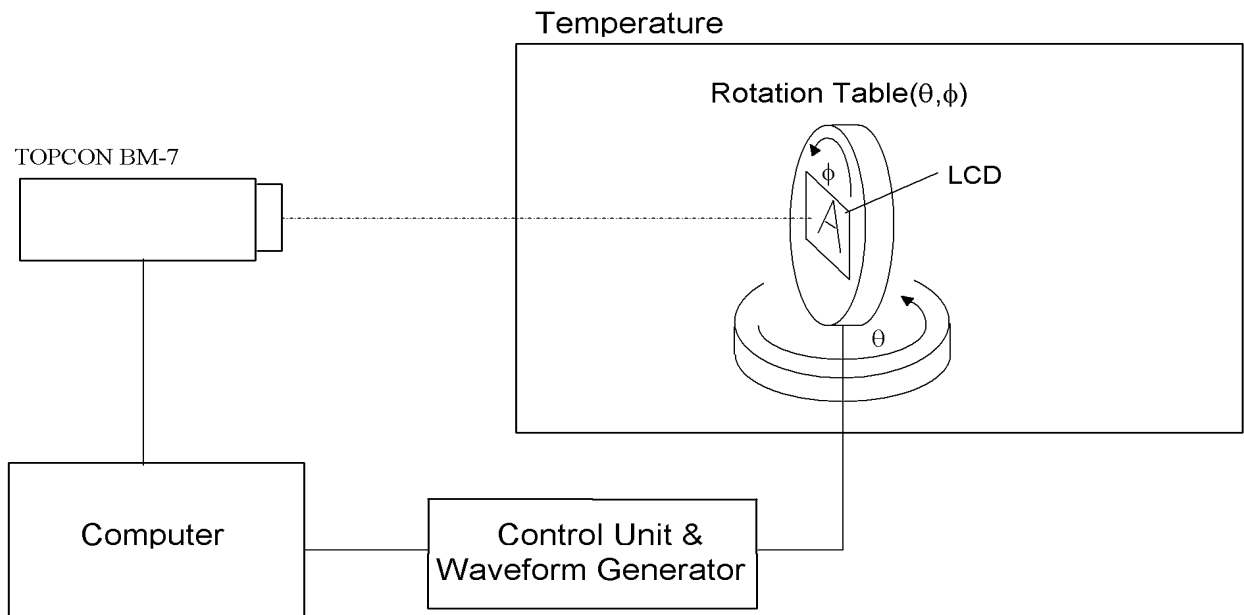

(4) Method of Measuring

Set rotation table to  $\phi=0^\circ$  and set BM-7 to contrast 10 to measure angle  $\pm\theta$  for left and right direction of horizontal viewing angle  $\phi$ . Also set rotation table to  $\phi=90^\circ$  and set BM-7 to contrast 10 to measure angle  $\pm\theta$  for up and down direction of vertical viewing angle  $\theta$ .

(Fig.3-4)

◆ Measuring Response Time

- (1) Measuring Device  
TOPCON BM-7, Measuring Field: 1°  
Tektronix Digital Oscilloscope
- (2) Measuring Point  
Center of display, same as Method of Brightness Measurement
- (3) Method of Measuring
  - Set LCD panel to  $\theta=0^\circ$ , and  $\phi=0^\circ$ .
  - Input white  $\rightarrow$  black  $\rightarrow$  white to display by switching signal voltage.
  - If the luminance is 0% and 100% immediately before the change of signal voltage, then  $\tau_r$  is optical response time during the change from 90% to 10% immediately after rise of signal voltage, and  $\tau_d$  is optical response time during the change from 10% to 90% immediately after decay of signal voltage.

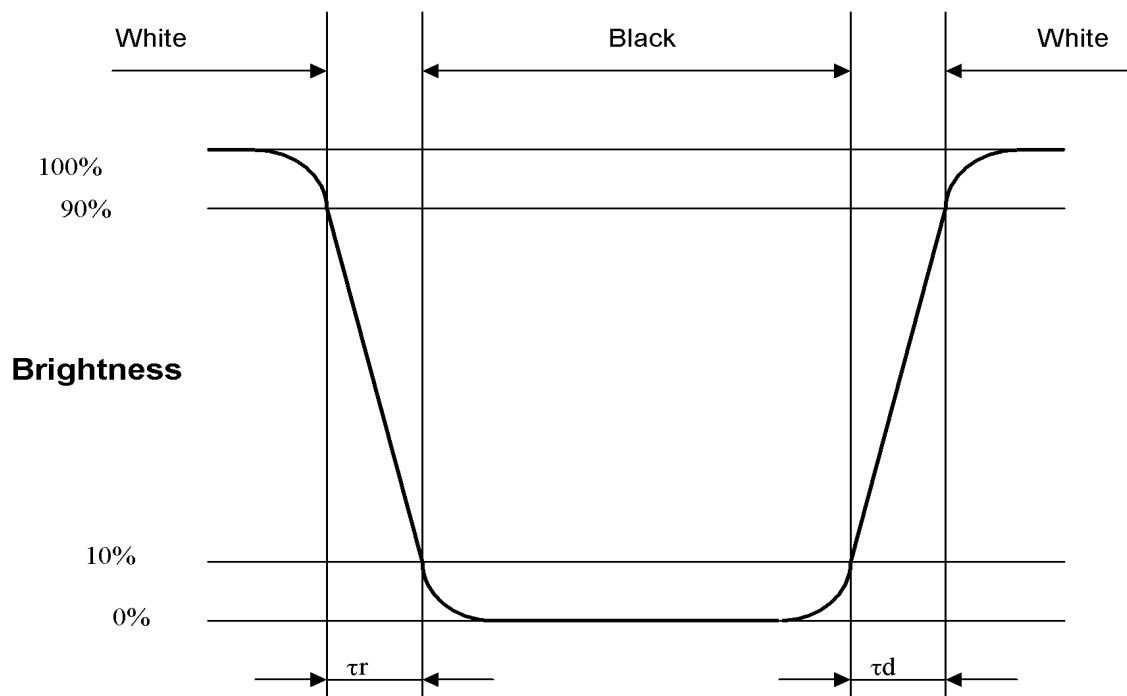



## 4. I/O Terminal

### 4.1 Pin assignment

#### CN 1(INTERFACE SIGNAL)

Used connector: DF9B-31P-1V (Hirose)

Corresponding connector: DF9B-31S-1V (Hirose)

Pin No.	Symbol	Function
1	GND	
2	DCLK	Clock signal for sampling catch data signal
3	HD	Horizontal sync signal
4	VD	Vertical sync signal
5	GND	
6	R0	Red data signal(LSB)
7	R1	Red data signal
8	R2	Red data signal
9	R3	Red data signal
10	R4	Red data signal
11	R5	Red data signal(MSB)
12	GND	
13	G0	Green data signal(LSB)
14	G1	Green data signal
15	G2	Green data signal
16	G3	Green data signal
17	G4	Green data signal
18	G5	Green data signal(MSB)
19	GND	
20	B0	Blue data signal(LSB)
21	B1	Blue data signal
22	B2	Blue data signal
23	B3	Blue data signal
24	B4	Blue data signal
25	B5	Blue data signal(MSB)
26	GND	
27	DENA	Data enable signal(to settle the viewing area)
28	VCC	Power Supply (DC 3.3V or 5V)
29	VCC	Power Supply (DC 3.3V or 5V)
30	TEST	This pin should be open. Test signal output for only internal test use.
31	REV	Reverse scan control. L = Normal, H = Reverse

\*) The shielding case is connected with GND

#### CN 2, CN 3 (BACKLIGHT)

Backlight-side connector: BHR-02(8.0)VS-1N(JST)

Inverter-side connector: SM02(8.0)B-BHS(JST)

Pin No.	Symbol	Function
1	CTH	VBLH(High Voltage)
3	CTL	VBLL(Low Voltage)

[Note] VBLH-VBLL = VL

## 4.2. Block Diagram

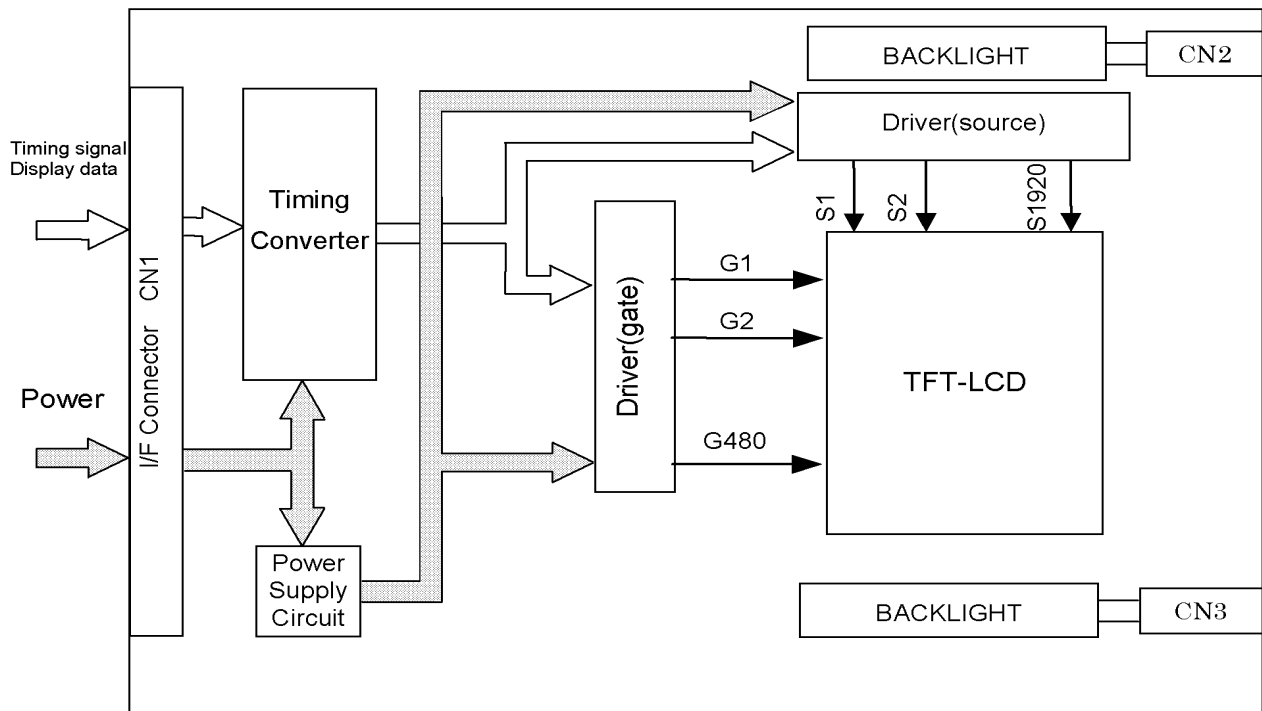

### BACKLIGHT

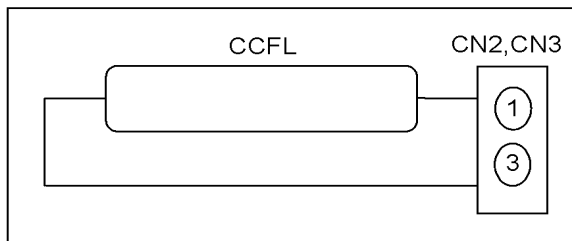

## 5. Test

No abnormal function and appearance are found after the following tests.

Conditions: Unless otherwise specified, tests will be conducted under the following condition.

Temperature:  $20\pm 5^{\circ}\text{C}$

Humidity :  $65\pm 5\% \text{RH}$

tests will be not conducted under functioning state.

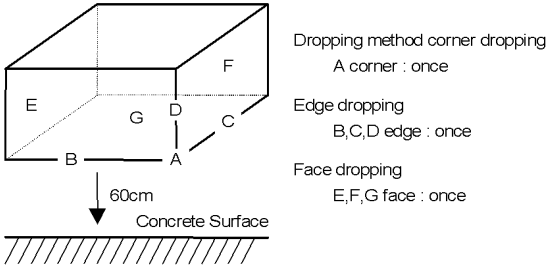
No.	Parameter	Conditions	Notes
1	High Temperature Operating	$60^{\circ}\text{C}$ , 96hrs (operation state)	
2	High Temperature Storage	$85^{\circ}\text{C}$ , 96hrs	2
3	Low Temperature Storage	$-25^{\circ}\text{C}$ , 96hrs	1,2
4	Damp Proof Test	$40^{\circ}\text{C}$ , 90~95%RH, 96hrs	1,2
5	Vibration Test	Frequency:10-57Hz/Vibration width(one side):0.75mm :58-500Hz/Gravity: $9.8\text{m/s}^2$ Sweep time:11minutes Test period:3hrs for each direction of X,Y,Z	3
6	Shock	Shock level: $490\text{m/s}^2$ Waveform:half sinusoidal wave, 11ms Number of shocks : One shock input in each direction of three mutually perpendicular axis for a total of six shock inputs	
7	Shock Test	To be measured after dropping from 60cm high on the concrete surface in packing state. 	

Note 1: No dew condensation to be observed.

Note 2: The function test shall be conducted after 4 hours storage at the normal Temperature and humidity after removed from the test chamber.

Note 3: Vibration test will be conducted to the product itself without putting it in a container.

## 6. Appearance Standards

### 6.1. Inspection conditions

The LCD shall be inspected under 40W white fluorescent light.

The distance between the eyes and the sample shall be more than 30cm.

All directions for inspecting the sample should be within 45° against perpendicular line.

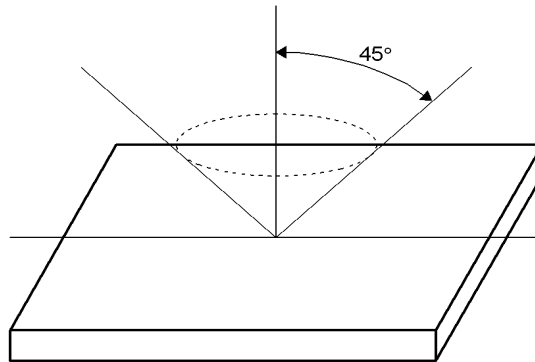

### 6.2. Definition of applicable Zones

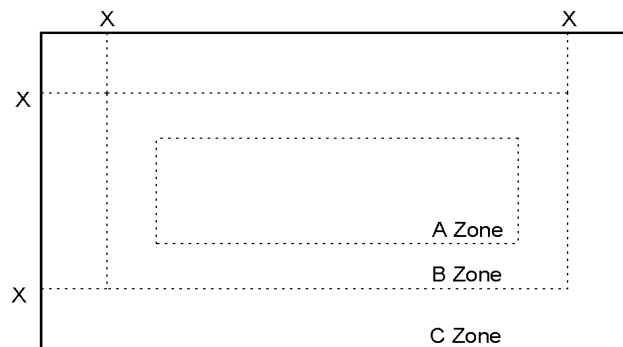

X : Maximum Seal Line

A Zone : Active display area

B Zone : Out of active display area up to viewing area

C Zone : Rest parts

A Zone + B Zone = Viewing area

### 6.3 Standards

No.	Parameter	Criteria																									
1	Polarizer Scratches	<table border="1"> <thead> <tr> <th colspan="2">Zone</th> <th colspan="3">Acceptable Number</th> </tr> <tr> <th>X(mm)</th> <th>Y(mm)</th> <th>A</th> <th>B</th> <th>C</th> </tr> </thead> <tbody> <tr> <td><math>L \leq 15</math></td> <td><math>0.01 &lt; W \leq 0.05</math></td> <td colspan="2">4</td> <td>*</td> </tr> <tr> <td><math>L &gt; 15</math></td> <td><math>W &gt; 0.01</math></td> <td colspan="2">0</td> <td>*</td> </tr> <tr> <td>-</td> <td><math>W &gt; 0.05</math></td> <td colspan="2">0</td> <td>*</td> </tr> </tbody> </table> <p>X : Length, Y : Width * : Disregard</p>	Zone		Acceptable Number			X(mm)	Y(mm)	A	B	C	$L \leq 15$	$0.01 < W \leq 0.05$	4		*	$L > 15$	$W > 0.01$	0		*	-	$W > 0.05$	0		*
Zone		Acceptable Number																									
X(mm)	Y(mm)	A	B	C																							
$L \leq 15$	$0.01 < W \leq 0.05$	4		*																							
$L > 15$	$W > 0.01$	0		*																							
-	$W > 0.05$	0		*																							
2	DENT	<table border="1"> <thead> <tr> <th colspan="2">Zone</th> <th colspan="3">Acceptable Number</th> </tr> <tr> <th colspan="2">Dimension (mm)</th> <th>A</th> <th>B</th> <th>C</th> </tr> </thead> <tbody> <tr> <td colspan="2"><math>0.30 &lt; D \leq 0.50</math></td> <td colspan="2">4</td> <td>*</td> </tr> <tr> <td colspan="2"><math>0.50 &lt; D</math></td> <td colspan="2">0</td> <td>*</td> </tr> </tbody> </table> <p>D : Average Diameter = (long+short)/2 * : Disregard</p>	Zone		Acceptable Number			Dimension (mm)		A	B	C	$0.30 < D \leq 0.50$		4		*	$0.50 < D$		0		*					
Zone		Acceptable Number																									
Dimension (mm)		A	B	C																							
$0.30 < D \leq 0.50$		4		*																							
$0.50 < D$		0		*																							
3	BLACK and WHITE SPOT BUBBLE	<table border="1"> <thead> <tr> <th colspan="2">Zone</th> <th colspan="3">Acceptable Number</th> </tr> <tr> <th colspan="2">Dimension (mm)</th> <th>A</th> <th>B</th> <th>C</th> </tr> </thead> <tbody> <tr> <td colspan="2"><math>0.30 &lt; D \leq 0.50</math></td> <td colspan="2">5</td> <td>*</td> </tr> <tr> <td colspan="2"><math>0.50 &lt; D</math></td> <td colspan="2">0</td> <td>*</td> </tr> </tbody> </table>	Zone		Acceptable Number			Dimension (mm)		A	B	C	$0.30 < D \leq 0.50$		5		*	$0.50 < D$		0		*					
Zone		Acceptable Number																									
Dimension (mm)		A	B	C																							
$0.30 < D \leq 0.50$		5		*																							
$0.50 < D$		0		*																							
4	LINT	<table border="1"> <thead> <tr> <th colspan="2">Zone</th> <th colspan="3">Acceptable Number</th> </tr> <tr> <th>X(mm)</th> <th>Y(mm)</th> <th>A</th> <th>B</th> <th>C</th> </tr> </thead> <tbody> <tr> <td><math>L \leq 3.0</math></td> <td><math>W \leq 0.15</math></td> <td colspan="2">4</td> <td>*</td> </tr> <tr> <td><math>L &gt; 3.0</math></td> <td><math>W \leq 0.15</math></td> <td colspan="2">0</td> <td>*</td> </tr> <tr> <td>-</td> <td><math>W &gt; 0.15</math></td> <td colspan="2">According to BLACK SPOT</td> <td>*</td> </tr> </tbody> </table> <p>X : Length, Y : Width * : Disregard</p>	Zone		Acceptable Number			X(mm)	Y(mm)	A	B	C	$L \leq 3.0$	$W \leq 0.15$	4		*	$L > 3.0$	$W \leq 0.15$	0		*	-	$W > 0.15$	According to BLACK SPOT		*
Zone		Acceptable Number																									
X(mm)	Y(mm)	A	B	C																							
$L \leq 3.0$	$W \leq 0.15$	4		*																							
$L > 3.0$	$W \leq 0.15$	0		*																							
-	$W > 0.15$	According to BLACK SPOT		*																							

No.	Parameter	Criteria																			
5	(a) Bright Dot (b) Dark Dot	<table border="1"> <thead> <tr> <th rowspan="2">Zone Dimension (mm)</th> <th colspan="3">Acceptable Number</th> </tr> <tr> <th>A</th> <th>B</th> <th>C</th> </tr> </thead> <tbody> <tr> <td>Bright Dot</td> <td colspan="2">7 (<math>G \leq 3</math>)</td> <td>*</td> </tr> <tr> <td>Dark Dot</td> <td colspan="2">7</td> <td>*</td> </tr> <tr> <td>TOTAL</td> <td colspan="3">10</td> </tr> </tbody> </table>	Zone Dimension (mm)	Acceptable Number			A	B	C	Bright Dot	7 ( $G \leq 3$ )		*	Dark Dot	7		*	TOTAL	10		
		Zone Dimension (mm)		Acceptable Number																	
			A	B	C																
		Bright Dot	7 ( $G \leq 3$ )		*																
Dark Dot	7		*																		
TOTAL	10																				
6	TWO Adjacent Dot	<table border="1"> <thead> <tr> <th rowspan="2">Zone Dimension (mm)</th> <th colspan="3">Acceptable Number</th> </tr> <tr> <th>A</th> <th>B</th> <th>C</th> </tr> </thead> <tbody> <tr> <td>Bright Dot</td> <td colspan="2">3 PAIRS</td> <td>*</td> </tr> <tr> <td>Dark Dot</td> <td colspan="2">3 PAIRS</td> <td>*</td> </tr> </tbody> </table>	Zone Dimension (mm)	Acceptable Number			A	B	C	Bright Dot	3 PAIRS		*	Dark Dot	3 PAIRS		*				
		Zone Dimension (mm)		Acceptable Number																	
			A	B	C																
Bright Dot	3 PAIRS		*																		
Dark Dot	3 PAIRS		*																		
7	Three or More Adjacent Dot	NOT ALLOWED																			
8		<table border="1"> <thead> <tr> <th rowspan="2">Zone Dimension (mm)</th> <th colspan="3">Acceptable Number</th> </tr> <tr> <th>A</th> <th>B</th> <th>C</th> </tr> </thead> <tbody> <tr> <td>Bright Dot</td> <td colspan="2">5 mm</td> <td>*</td> </tr> <tr> <td>Dark Dot</td> <td colspan="2">5 mm</td> <td>*</td> </tr> </tbody> </table>	Zone Dimension (mm)	Acceptable Number			A	B	C	Bright Dot	5 mm		*	Dark Dot	5 mm		*				
		Zone Dimension (mm)		Acceptable Number																	
			A	B	C																
Bright Dot	5 mm		*																		
Dark Dot	5 mm		*																		
9	Line Defect	NOT ALLOWED																			

Note 1: Bright Dot is defined as follows:

Visible through 5% transmission ND filter under the condition that black image (color 0) is on the display.

Note 2: Dark Dot is defined as follows:

Recognizable darker than around under the condition that each R(63), G(63), B(63) image is on the display.

Note 3: Definition of adjacent

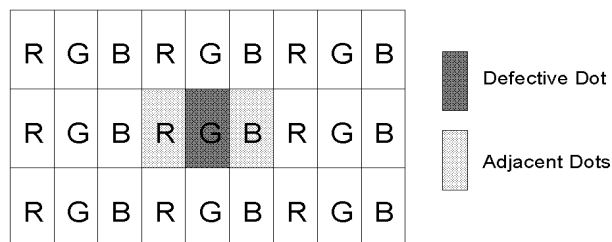

The defects that are not defined above and considered to be problem shall be reviewed and discussed by both parties.

## 7. Code System of Production Lot

The production lot of module is specified as follows.

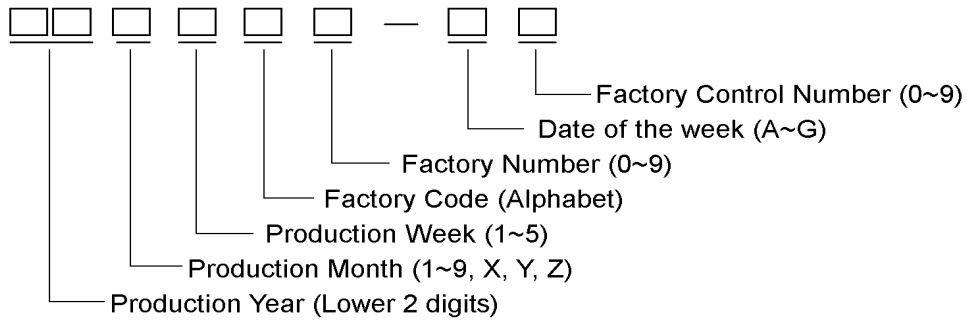

## 8. Type Number

The type number of module is specified as follows.

T-51750GD065J-FW-ADN

## 9. Applying Precautions

Please contact us when questions and/or new problems not specified in this Specifications arise.

## 10. Precautions Relating Product Handling

The Following precautions will guide you in handling our product correctly.

### 1) Liquid crystal display devices

1. The liquid crystal display panel used in the liquid crystal display module is made of plate glass. Avoid any strong mechanical shock. Should the glass break handle it with care. The polarizer adhering to the surface of the LCD is made of a soft material. Guard against scratching it.



### 2) Care of the liquid crystal display module against static electricity discharge.

1. When working with the module, be sure to ground your body and any electrical equipment you may be using. We strongly recommend the use of anti static mats (made of rubber), to protect worktables against the hazards of electrical shock.
2. Avoid the use of work clothing made of synthetic fibers. We recommend cotton clothing or other conductivity-treated fibers.
3. Slowly and carefully remove the protective film from the LCD module, since this operation can generate static electricity.

### 3) When the LCD module must be stored for long periods of time:

1. Protect the modules from high temperature and humidity.

Conditions:            Temperature: 0°C~40°C  
                                 Humidity : Less than 60%RH  
                                 No dew condensation to be observed.

2. Keep the modules out of direct sunlight or direct exposure to ultraviolet rays.
3. Protect the modules from excessive external forces.

### 4) Use the module with a power supply that is equipped with an overcurrent protector circuit, since the module is not provided with this protective feature.

### 5) Do not ingest the LCD fluid itself should it leak out of a damaged LCD module. Should hands or clothing come in contact with LCD fluid, wash immediately with soap.

### 6) Conductivity is not guaranteed for models that use metal holders where solder connections between the metal holder and the PCB are not used. Please contact us to discuss appropriate ways to assure conductivity.

### 7) For models which use CFL:

1. High voltage of 1000V or greater is applied to the CFL cable connector area. Care should be taken not to touch connection areas to avoid burns.
2. Protect CFL cables from rubbing against the unit and thus causing the wire jacket to become worn.
3. The use of CFLs for extended periods of time at low temperatures will significantly shorten their service life.
4. After storing the product (or LCD) under low temperature and/or in dark atmosphere for a long period of time, CCFL may take longer time to reach its specified brightness.

### 8) For models which use touch panels:

1. Do not stack up modules since they can be damaged by components on neighboring modules.
2. Do not place heavy objects on top of the product. This could cause glass breakage.



9) For models which use COG, TAB, or COF:

1. The mechanical strength of the product is low since the IC chip faces out unprotected from the rear. Be sure to protect the rear of the IC chip from external forces.
2. Given the fact that the rear of the IC chip is left exposed, in order to protect the unit from electrical damage, avoid installation configurations in which the rear of the IC chip runs the risk of making any electrical contact.

10) Models which use flexible cable, heat seal, or TAB:

1. In order to maintain reliability, do not touch or hold by the connector area.
2. Avoid any bending, pulling, or other excessive force, which can result in broken connections.

11) In case of buffer material such as cushion / gasket is assembled into LCD module, it may have an adverse effect on connecting parts (LCD panel-TCP / HEAT SEAL / FPC / etc., PCB-TCP / HEAT SEAL / FPC etc., TCP-HEAT SEAL, TCP-FPC, HEAT SEAL-FPC, etc.) depending on its materials. Please check and evaluate these materials carefully before use.

12) In case of acrylic plate is attached to front side of LCD panel, cloudiness (very small cracks) can occur on acrylic plate, being influenced by some components generated from polarizer film. Please check and evaluate those acrylic materials carefully before use.

## 11. Warranty

This product has been manufactured to your company's specifications as a part for use in your company's general electronic products. It is guaranteed to perform according to delivery specifications. For any other use apart from general electronic equipment, we cannot take responsibility if the product is used in medical devices, nuclear power control equipment, aerospace equipment, fire and security systems, or any other applications in which there is a direct risk to human life and where extremely high levels of reliability are required. If the product is to be used in any of the above applications, we will need to enter into a separate product liability agreement.

1. We cannot accept responsibility for any defect, which may arise from additional manufacturing of the product (including disassembly and reassembly), after product delivery.
2. We cannot accept responsibility for any defect, which may arise after the application of strong external force to the product.
3. We cannot accept responsibility for any defect, which may arise due to the application of static electricity after the product has passed your company's acceptance inspection procedures.
4. When the product is in CFL models, CFL service life and brightness will vary according to the performance of the inverter used, leaks, etc. We cannot accept responsibility for product performance, reliability, or defect, which may arise.
5. We cannot accept responsibility for intellectual property of a third party, which may arise through the application of our product to your assembly with exception to those issues relating directly to the structure or method of manufacturing of our product.
6. We will not be held responsible for any quality issue(s) after two years and beyond from its production date indicated on the lot number (please refer to "Code System of Production Lot" indicated earlier in this specification).