

FM1233D 3-Pin μ C Supervisor Circuit

General Description

The FM1233D is a supervisor circuit that monitors a microprocessor power supply or other system voltage and issues a reset pulse when a fault condition exists. Several different threshold voltages are offered to accommodate 5V systems with different tolerances.

The device features a precision temperature-compensated voltage reference and comparator. When V_{CC} falls to the threshold voltage, a RESET pulse is issued, holding the output in the active state. When power rises above V_{TH} , the reset remains for approximately 250 ms to allow the system clock and other circuits to stabilize. The reset output of FM1233D is of open-drain active low type.

Features

- Precision monitoring of 5V and lower voltage microprocessor systems
- V_{TH} values of 4.62V, 4.38V and 4.12V
- Automatic restart of microprocessor after power failure
- 140ms (min) power-on $\overline{\text{RESET}}$ delay
- Internal 5k Ω pull-up resistor
- Other reset choices available: 32 to 256ms
- Operating Temperature -40°C to +105°C
- SOT23-3 package

Typical Operating Circuit

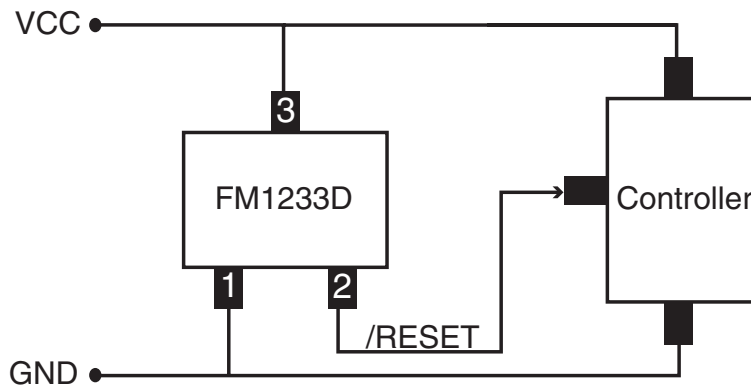

Connection Diagram

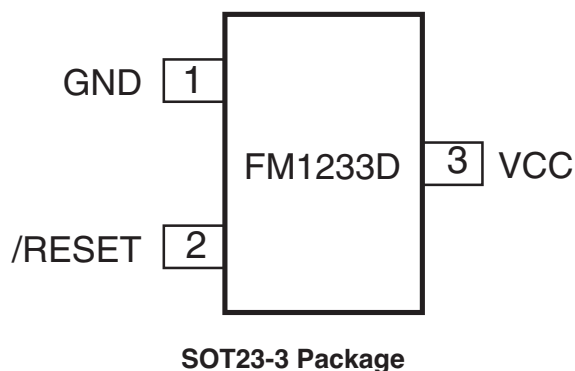

Absolute Maximum Ratings

Voltage on any pin relative to GND		Continuous Power Dissipation ($T_A = 70^\circ\text{C}$)	
V_{CC}	-0.3V to +6.0V	SOT23 (derate 4mW above 70°C)	300mW
RESET, $\overline{\text{RESET}}$	-0.3V to ($V_{CC} + 0.3\text{V}$)	Operating Temperature Range	-40°C to +105°C
Input Current	20mA	Storage Temperature Range	-65°C to +150°C
Output Current (RESET, $\overline{\text{RESET}}$)	20mA	Lead Temperature (soldering, 10s)	+300°C

These are stress ratings only, and functional operation is not implied for these levels or beyond. Exposure to Absolute Maximum Rating conditions for extended periods may affect device reliability.

Electrical Characteristics ($V_{CC} = 5\text{V}$; $T_A = -40^\circ\text{C}$ to $+105^\circ\text{C}$ unless otherwise noted) (Note 1)

Parameter	Symbol	Conditions	Min	Typ	Max	Units
Operating Voltage	V_{CC}		4.5	5	5.5	V
Supply Current	I_{CC}	$V_{CC} < 5\text{V}$		3	6	μA
Reset Threshold	V_{TH}	FM1233DD	4.40	4.63	4.86	V
Reset Threshold	V_{TH}	FM1233DE	4.16	4.38	4.55	V
Reset Threshold	V_{TH}	FM1233DF	3.91	4.12	4.32	V
Reset Output Voltage	V_{OH}	FM1233D $I_{SOURCE} = 150 \mu\text{A}$ $V_{CC} = V_{TH(max)}$	$0.8V_{CC}$			V
Reset Output Voltage	V_{OL}	FM1233D $I_{SINK} = 5\text{mA}$ $V_{CC} = V_{TH(min)}$			0.4	V
Reset Timeout Period	t_{RST}	FM1233D	140	256	560	ms

Note 1: Testing at production is done at 25°C only. Limits over temperature are guaranteed by design.

Note 2: $C = 100\text{pF}$, $V_{CC} = 3.3\text{V}$. It is recommended to connect 100pF capacitor between the Reset pin and Ground pin if pushbutton reset is implemented.

Typical Operating Characteristics

Supply Current Vs. Temperature

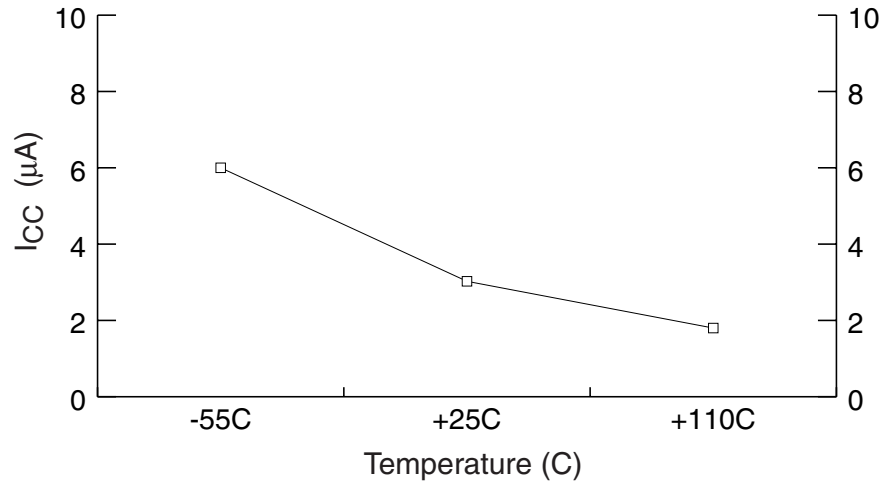

Power up Reset Timeout Vs. Temperature

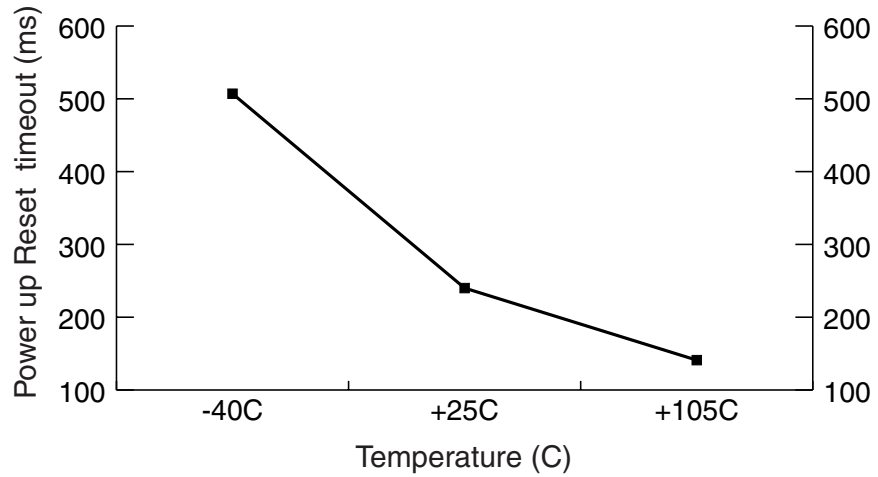

Pin Descriptions

Pin Number	Name	Function
1	GND	GROUND
2	/RESET	/RESET remains LOW while V_{CC} is below V_{TH} , and for at least 140ms after V_{CC} rises above V_{TH} .
3	V_{CC}	

Circuit Timing (Ex: FM1233D)

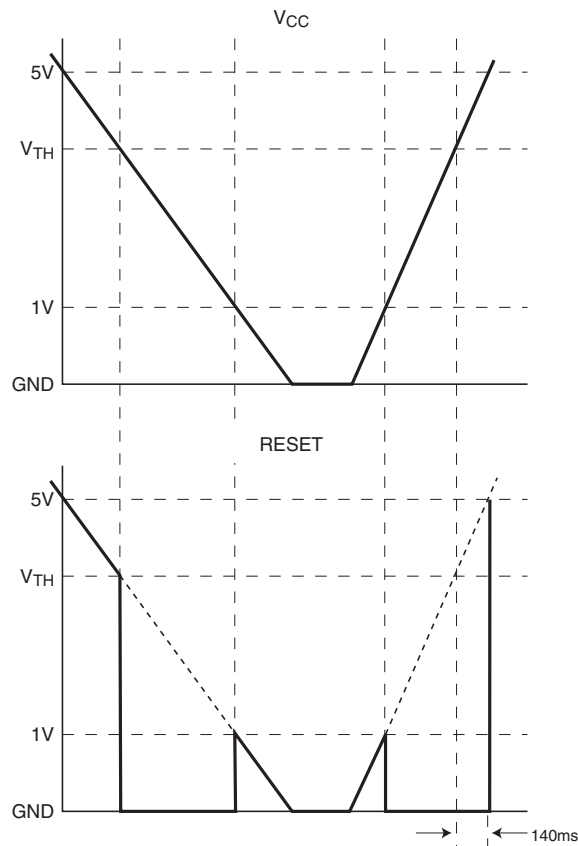

When operating properly with 5V V_{CC} (for example), /RESET will also be about 5V. When V_{CC} starts to fall, /RESET will follow it down as shown. When V_{CC} drops below V_{TH} , /RESET drops to ground ("issues a RESET") and stays there unless V_{CC} also falls below its minimum operating voltage, approx. 1V. At this point, the supervisor loses control, and its output may rise, only to again follow V_{CC} down to the ground.

When V_{CC} begins to rise, /RESET follows it until 1.0V or so is reached, whereupon the device regains control, /RESET is pulled to ground, etc. When V_{CC} rises above V_{TH} , /RESET comes out of RESET 140 ms later.

If it is required that a lower value than GND + 1.0V is needed on RESET signal during $V_{CC} \leq 1V$, a 100K resistor may be used on the device output to GND.

General Description

The FM1233D features a highly accurate voltage reference to which V_{CC} is compared. Once V_{CC} is below the specified threshold, it will drive the /RESET line and continue to hold it low until V_{CC} returns above the threshold and the time for the RESET pulse duration has expired. The FM1233D is immune to short negative going transients on the V_{CC} line. The placement of a 0.1 μ F bypass capacitor as close as possible to the V_{CC} pin provides additional transient immunity.

For a V_{CC} value below 1.0V, the FM1233D does not sink very much current on the /RESET pin. This is not a problem in most systems since common devices are not functional in this range. If it is desired for the FM1233D reset to be functional below this range, use a 100K Ω pull-down resistor between /RESET and V_{SS} .

Ordering Information

Part Number	Top Marking	RESET Threshold (V)	RESET Pulse Width (ms)	Output Type	Package Type
FM1233DDS3	3DD	4.62	256ms	Open-Drain, active LOW	3-Pin, SOT23
FM1233DES3	3DE	4.38	256ms	Open-Drain, active LOW	3-Pin, SOT23
FM1233DFS3	3DF	4.12	256ms	Open-Drain, active LOW	3-Pin, SOT23
FM1233DDES3 (Note 3)	3DDE	4.62	32ms	Open-Drain, active LOW	3-Pin, SOT23
FM1233DEES3 (Note 3)	3DEE	4.38	32ms	Open-Drain, active LOW	3-Pin, SOT23
FM1233DFES3 (Note 3)	3DFE	4.12	32ms	Open-Drain, active LOW	3-Pin, SOT23
FM1233DDFS3 (Note 3)	3DDF	4.62	64ms	Open-Drain, active LOW	3-Pin, SOT23
FM1233DEFS3 (Note 3)	3DEF	4.38	64ms	Open-Drain, active LOW	3-Pin, SOT23
FM1233DFFS3 (Note 3)	3DFF	4.12	64ms	Open-Drain, active LOW	3-Pin, SOT23
FM1233DDHS3 (Note 3)	3DDH	4.62	128ms	Open-Drain, active LOW	3-Pin, SOT23
FM1233DEHA3 (Note 3)	3DEH	4.38	128ms	Open-Drain, active LOW	3-Pin, SOT23

Note3: These devices are available upon special request only. Please contact Fairchild sales for availability and minimum ordering requirements.

Physical Dimensions inches (millimeters) unless otherwise noted

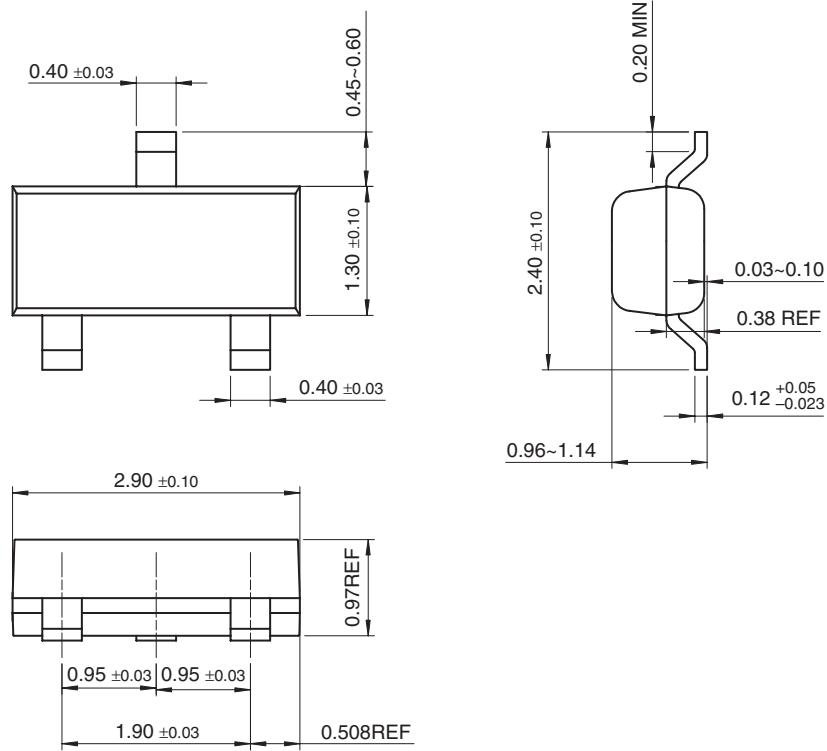

**SOT-23 Package Dimensions
FS Pkg Code AU**

Life Support Policy

Fairchild's products are not authorized for use as critical components in life support devices or systems without the express written approval of the President of Fairchild Semiconductor Corporation. As used herein:

1. Life support devices or systems are devices or systems which, (a) are intended for surgical implant into the body, or (b) support or sustain life, and whose failure to perform, when properly used in accordance with instructions for use provided in the labeling, can be reasonably expected to result in a significant injury to the user.
2. A critical component is any component of a life support device or system whose failure to perform can be reasonably expected to cause the failure of the life support device or system, or to affect its safety or effectiveness.

**Fairchild Semiconductor
Americas
Customer Response Center**
Tel: 1-888-522-5372

**Fairchild Semiconductor
Europe**
Fax: +44 (0) 1793-856858
Deutsch Tel: +49 (0) 8141-6102-0
English Tel: +44 (0) 1793-856856
Français Tel: +33 (0) 1-6930-3696
Italiano Tel: +39 (0) 2-249111-1

**Fairchild Semiconductor
Hong Kong**
8/F, Room 808, Empire Centre
68 Mody Road, Tsimshatsui East
Kowloon, Hong Kong
Tel: +852-2722-8338
Fax: +852-2722-8383

**Fairchild Semiconductor
Japan Ltd.**
4F, Natsume Bldg.
2-18-6, Yushima, Bunkyo-ku
Tokyo, 113-0034 Japan
Tel: 81-3-3818-8840
Fax: 81-3-3818-8841

Fairchild does not assume any responsibility for use of any circuitry described, no circuit patent licenses are implied and Fairchild reserves the right at any time without notice to change said circuitry and specifications.