

SPECIFICATION

Model No. : **SGP.25D**

Part No. : **SGP.1575.25.4.D.02**

Product Name : **GPS SMT Patch Antenna**

Features : 25mm*25mm*4mm
1575MHz Centre Frequency
Patent Pending

RoHS ✓ Halogen Free Compliant

Photo :



1. Introduction

This ceramic GPS patch antenna is based on smart **XtremeGain™** technology. It is mounted via SMT process and has been tuned as the optimal solution for the ublox C16-G25Q GSM/GPS Integrated reference Design.

The C16-G25Q GSM/GPS reference design is a complete and integrated solution for telematics applications such as fleet management, asset tracking, road pricing, and security/surveillance. It demonstrates the integration of u-blox' NEO-5Q GPS receiver with a LEON-G200 GPRS/GSM module. This 100% SMD solution uses SMT passive GPS (Taoglas SGP.25D) and GSM antenna (Taoglas PA.25A) and an on-board SIM Chip with activated phone number (SIM holder optional for mechanical (SIM)).

On the test fixture of 63.2 x 50.03 mm (GND Plane) the antenna has a centre frequency of 1567MHz ± 3MHz

2. Specification

| No | Parameter | Specification |
|----|-----------------------------------|-------------------------------------|
| 1 | Range of Receiving Frequency | 1575MHz +/- 1.023MHz |
| 2 | Bandwidth | 22 MHz min with Return Loss <-10dB |
| 3 | VSWR | 1.5 max |
| 4 | Gain at Zenith | +1.0 dBic typ. |
| 5 | Axial ratio | 4.0 dB Max. |
| 6 | Impedance | 50 Ω |
| 7 | Polarization | Right Hand Circular Polarization |
| 8 | Frequency Temperature Coefficient | 0 ± 20 ppm/ °C max @ -40°C to +85°C |
| 9 | Operating Temperature | -40°C to +85°C |

3. Electrical Specifications

3.1 Return Loss, SWR, Impedance (For Ublox C16-G25Q Reference Design)

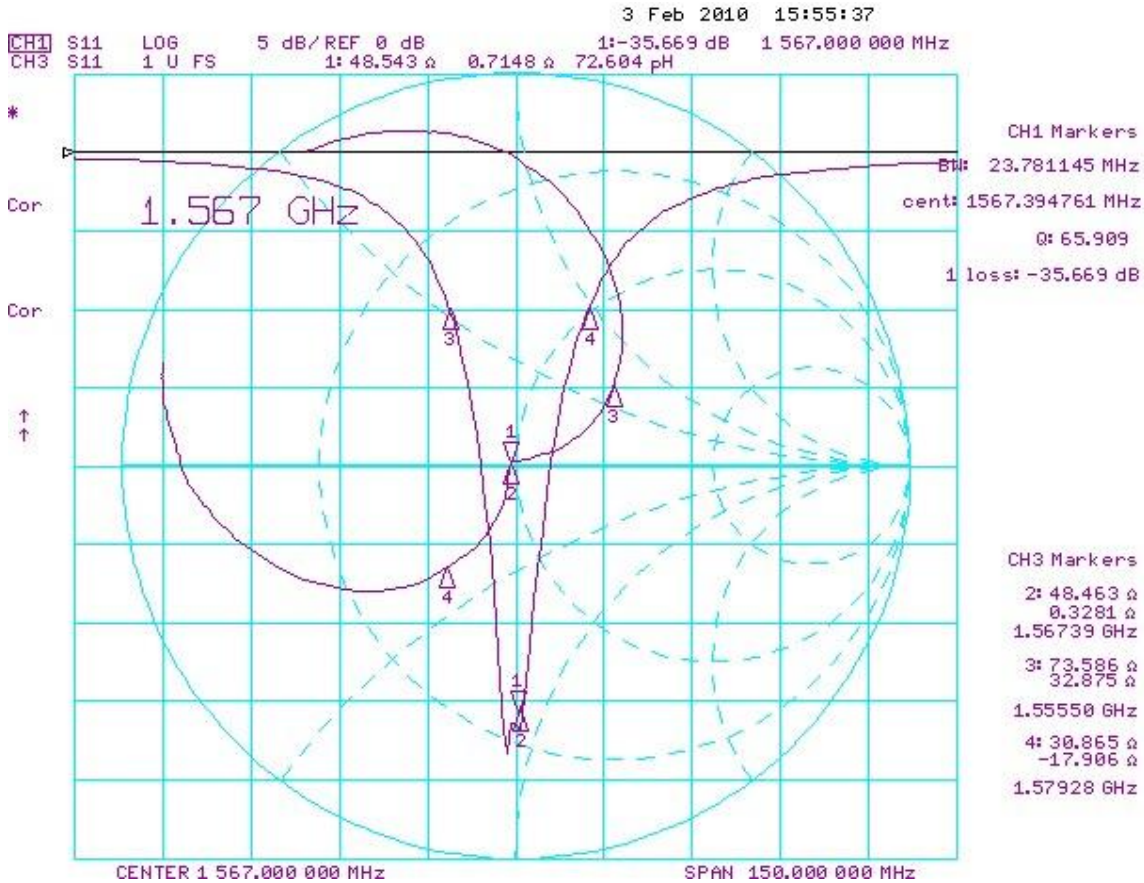

3.2 Matching Circuit

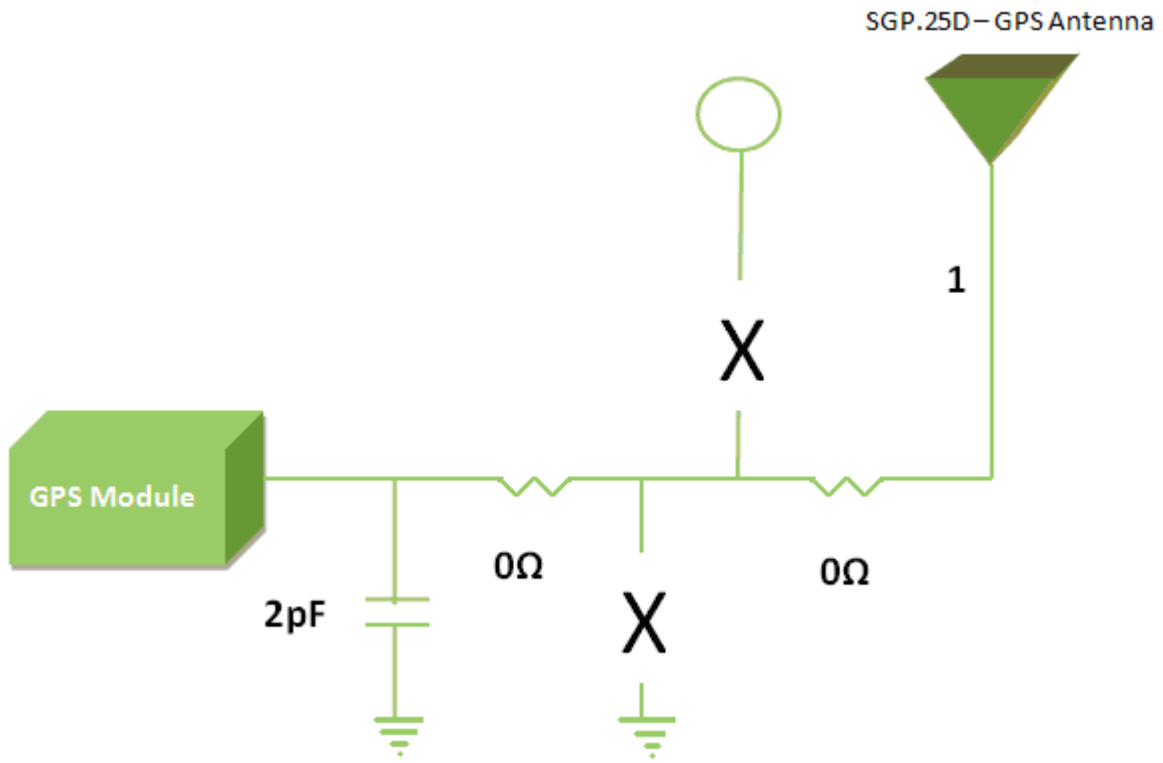

3.3 Axial Ratio

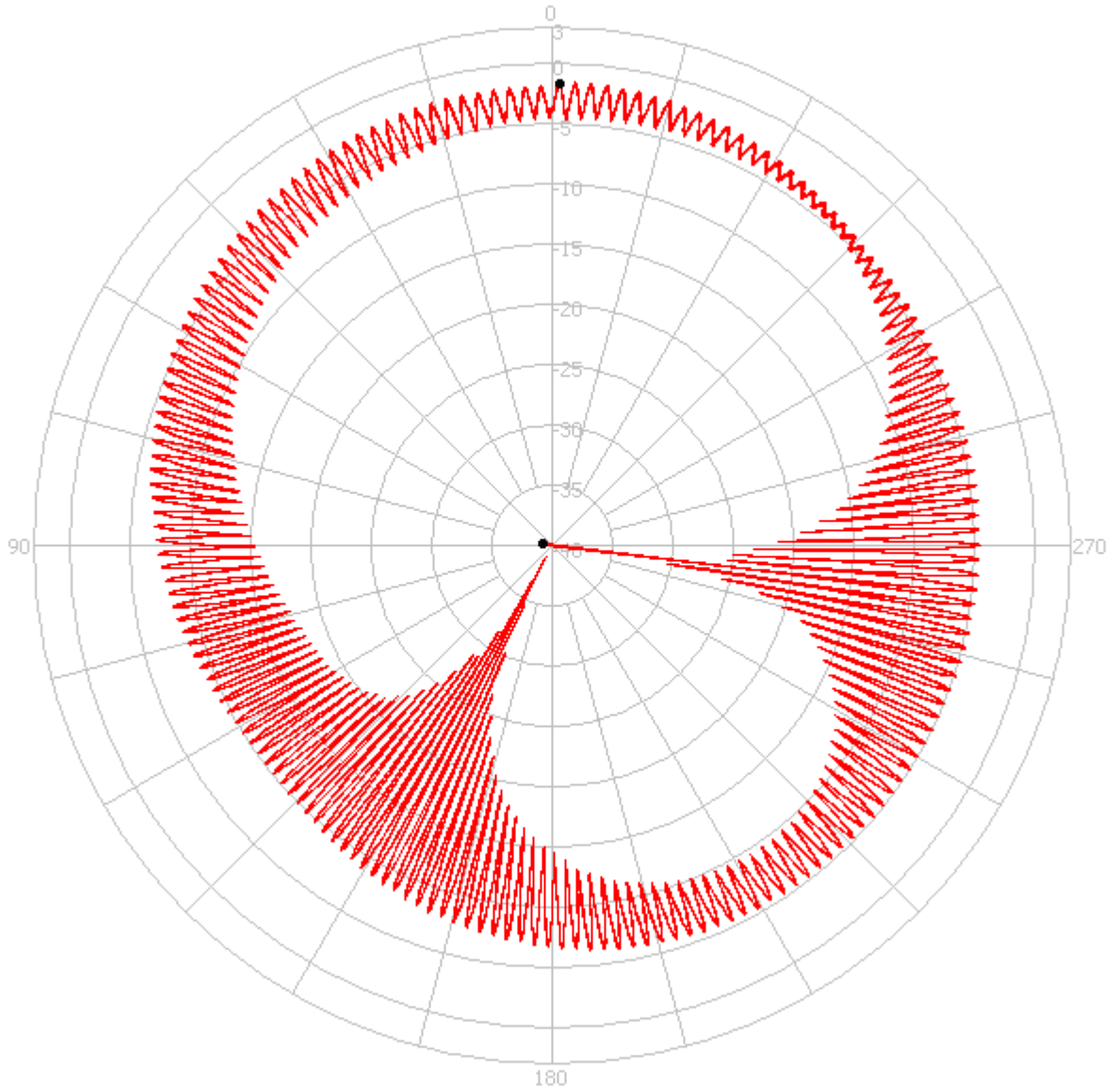

| Test Mode | Freq (MHz) | Max Gain (dBi) | Min Gain (dBi) | Avg Gain (dBi) | Source Polar. |
|-------------|------------|----------------|-----------------|----------------|---------------|
| Axial Ratio | 1575.42 | -1.67 / 359.10 | -40.80 / 263.03 | -6.46 | CP |

3.4 Cut plane patterns

X - Z Plane

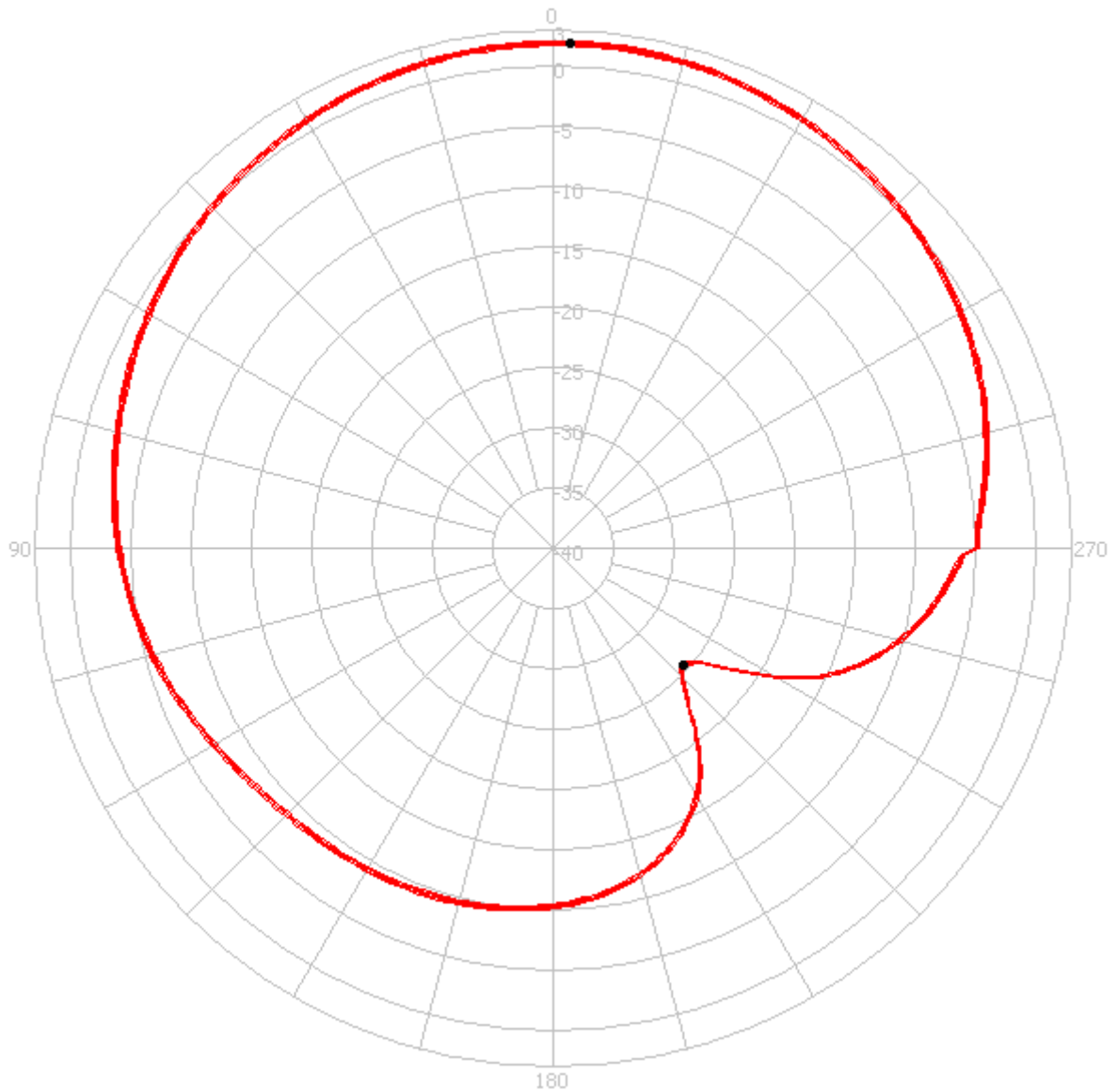

| Test Mode | Freq (MHz) | Max Gain (dBi) | Min Gain (dBi) | Avg Gain (dBi) | Source Polar. |
|-----------|------------|----------------|----------------|----------------|---------------|
| XZ | 1575.42 | -1.92 / 35.8 | -25.43 / 228 | -2.49 | RHCP |

Y - Z Plane

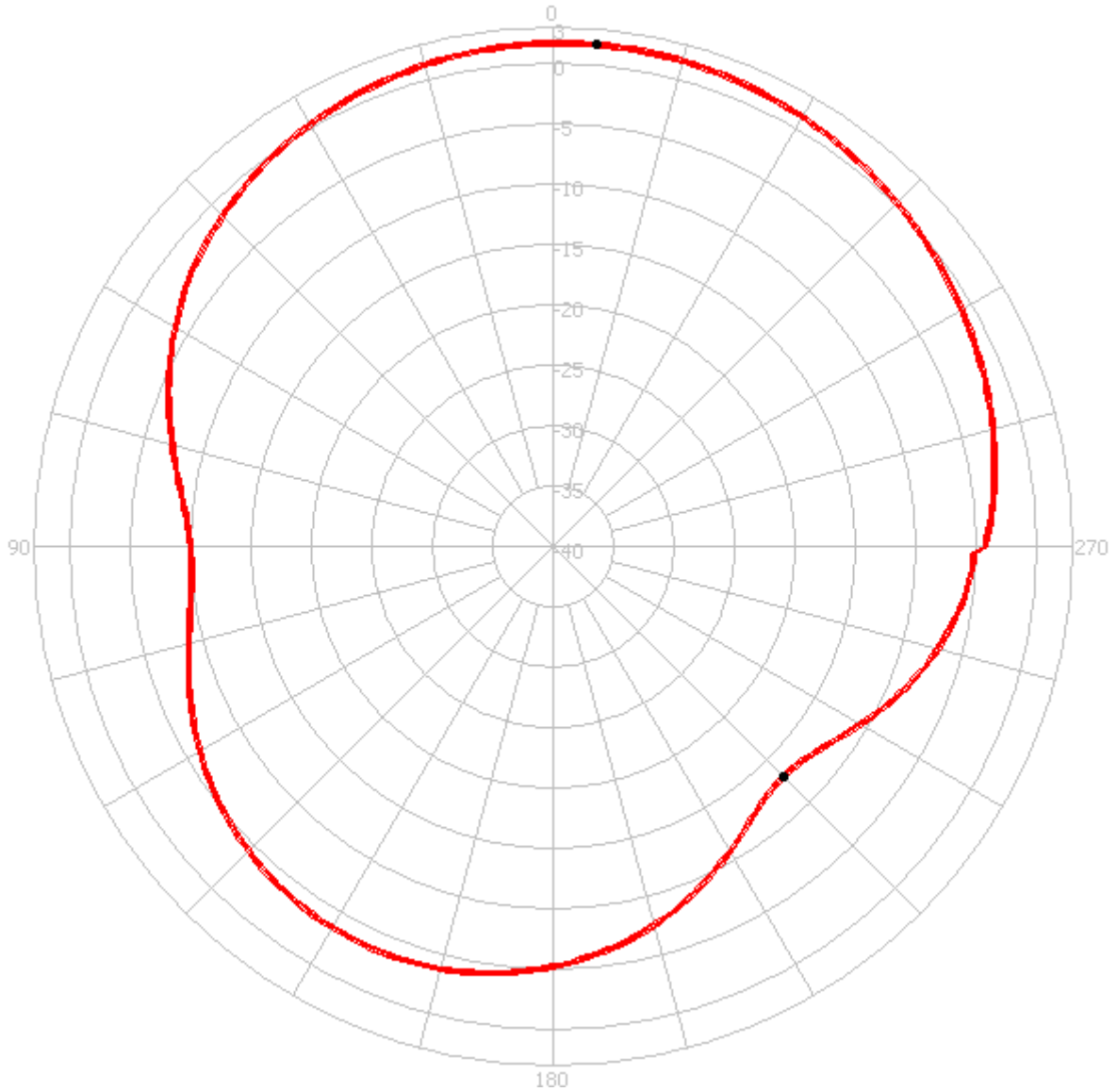

| Test Mode | Freq (MHz) | Max Gain (dBi) | Min Gain (dBi) | Avg Gain (dBi) | Source Polar. |
|-----------|------------|----------------|----------------|----------------|---------------|
| YZ | 1575.42 | -1.71 / 355 | -13.07 / 225 | -2.53 | RHCP |

4. Mechanical Specifications

4.1 Dimensions and Drawing

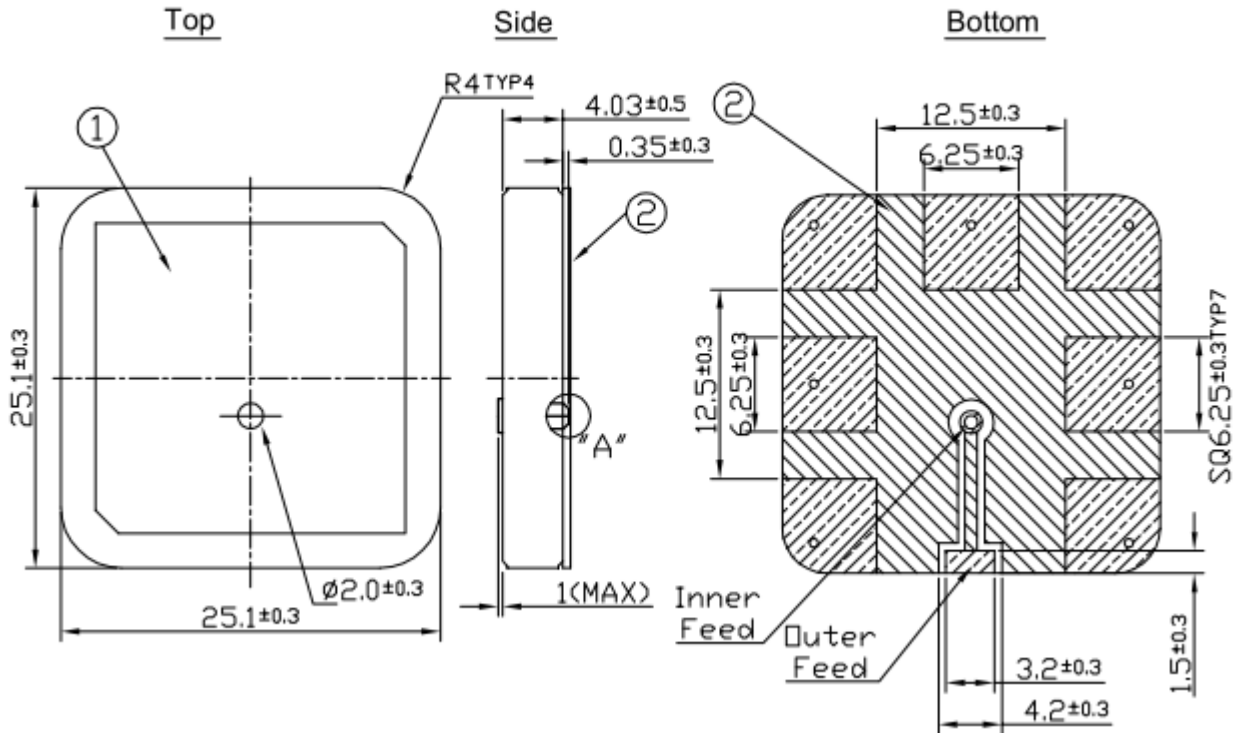

NOTE:

1. Solder mask
2. Area to be soldered
3. Dimension of 50 Ohm CPW dependent on individual board.
4. Matching circuit-capacitor and inductor values dependent on individual environment.
5. Must be soldered to complete antenna feed connection.

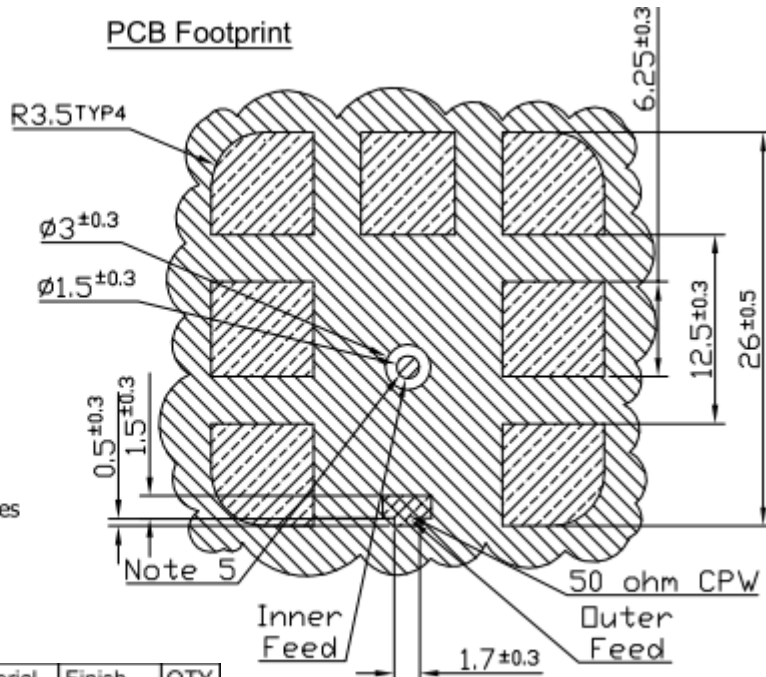

| | Name | Part no. | Material | Finish | QTY |
|---|----------------------|----------|----------|--------|-----|
| 1 | SGP.25 Patch 25x25x4 | SGP.25D | Ceramic | Clear | 1 |
| 2 | SGP.25 PCB | | FR 0.5t | Green | 1 |

4.2 Test Fixture and Measurements

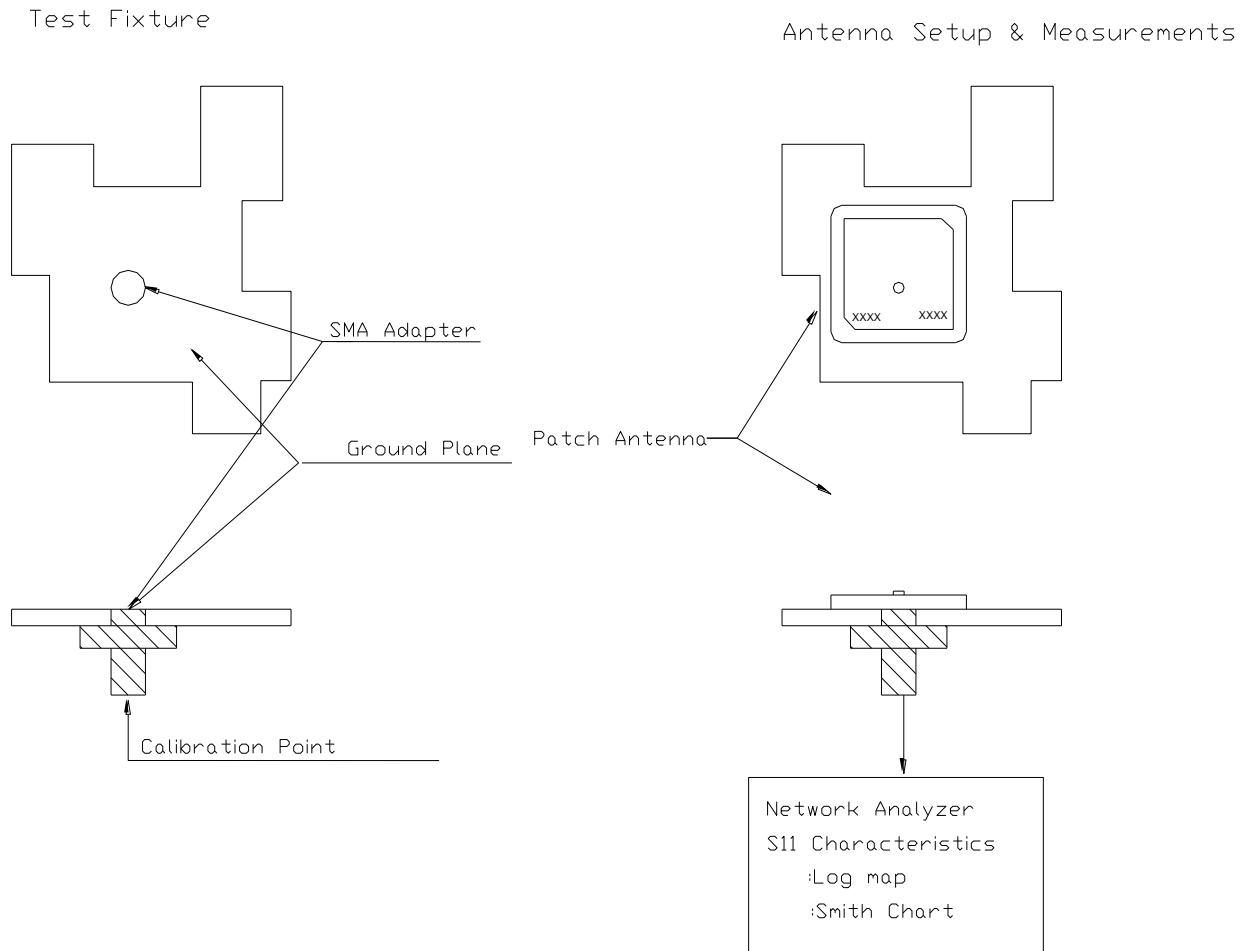

5. Antenna Recommended Soldering Conditions

5.1 Flux, Solder

- Use rosin-based flux. Don't use highly acidic flux with halide content exceeding 0.2wt%(chlorine conversion value).
- Use Sn solder.

5.2 Reflow soldering conditions

- Pre-heating should be in such a way that the temperature difference between solder and product surface is limited to 150°C max. Cooling into solvent after soldering also should be in such a way that temperature difference is limited to 100°C max. Unwrought pre-heating may cause cracks on the product, resulting in the deterioration of products quality.

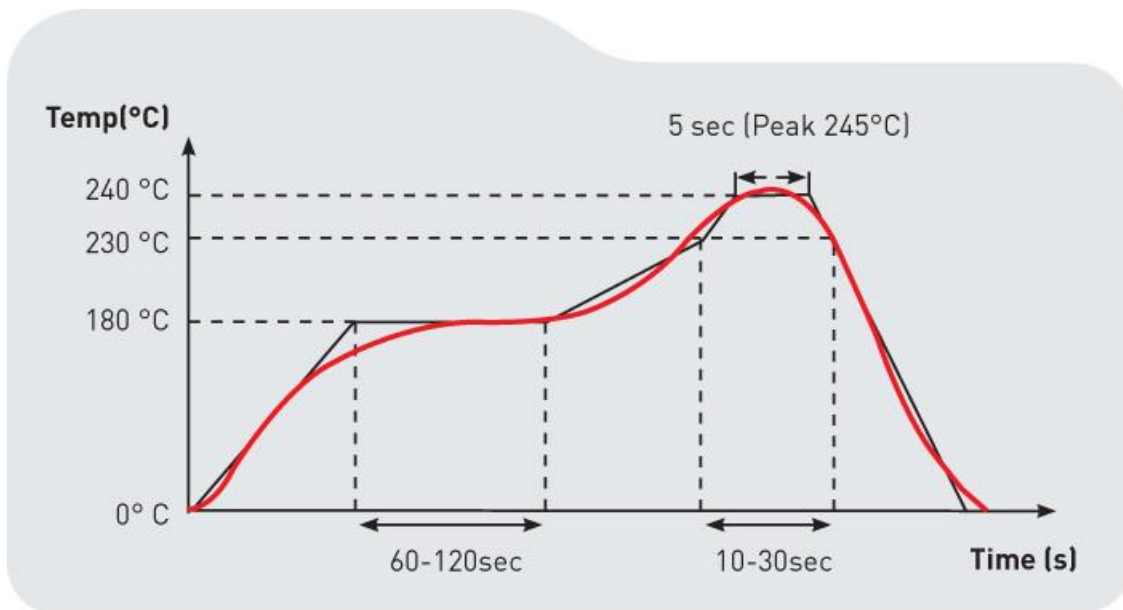

5.3 Reworking with soldering iron

- The following conditions must be strictly followed when using a soldering iron.

| | |
|-----------------------|--------------|
| Pre-heating | 150°, 1 min |
| Tip temperature | 290° max |
| Soldering iron output | 30w max |
| Soldering time | 3 second max |

6. Packaging

200 pieces/Reel/Inner carton,
4 reels in outer carton - (800)

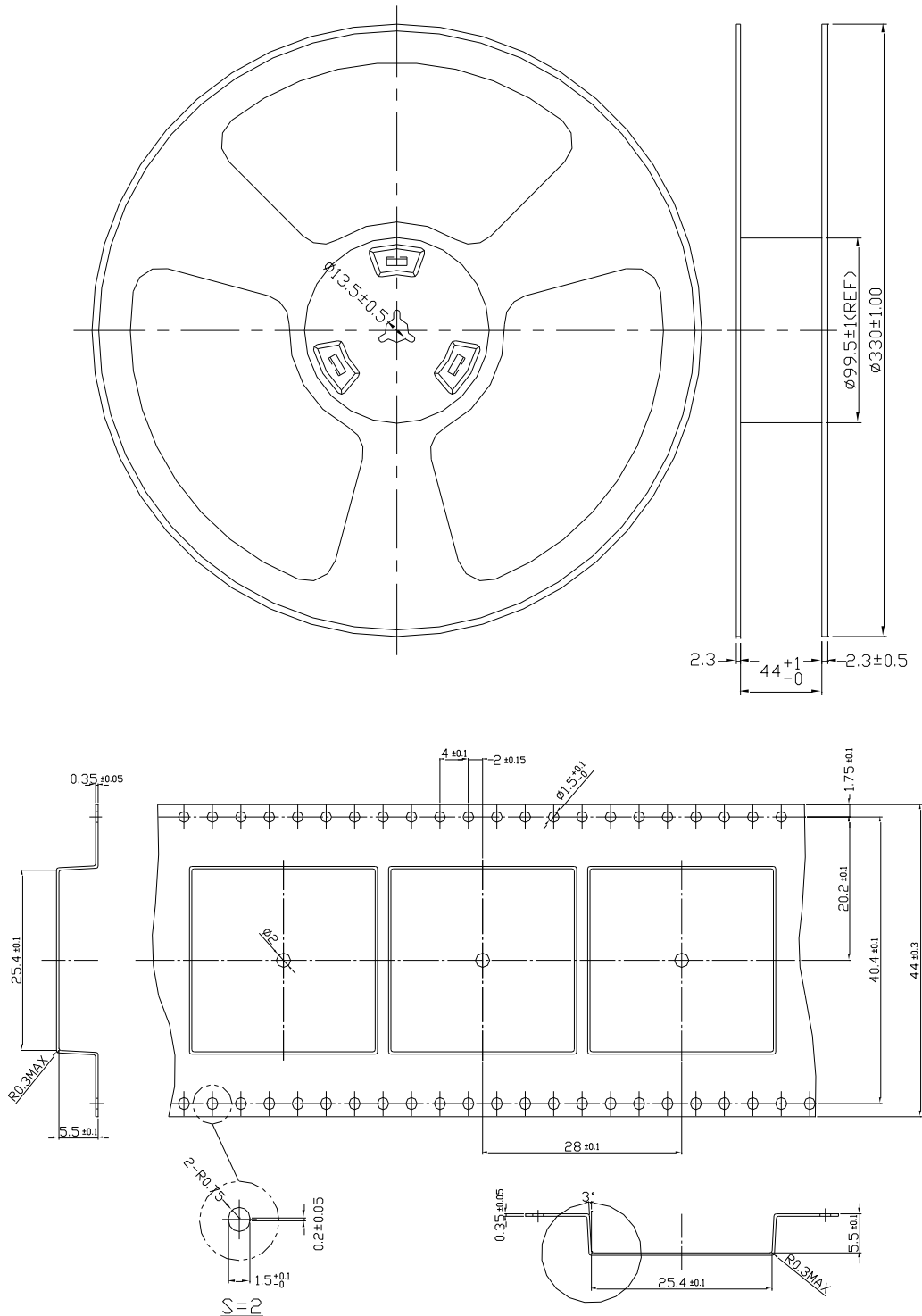

Unit: mm