

Silicon NPN Power Transistors

BU2508AF

DESCRIPTION

- With TO-3PFa package
- High voltage
- High speed switching

APPLICATIONS

- For use in horizontal deflection circuit of colour TV receivers

PINNING

PIN	DESCRIPTION
1	Base
2	Collector
3	Emitter

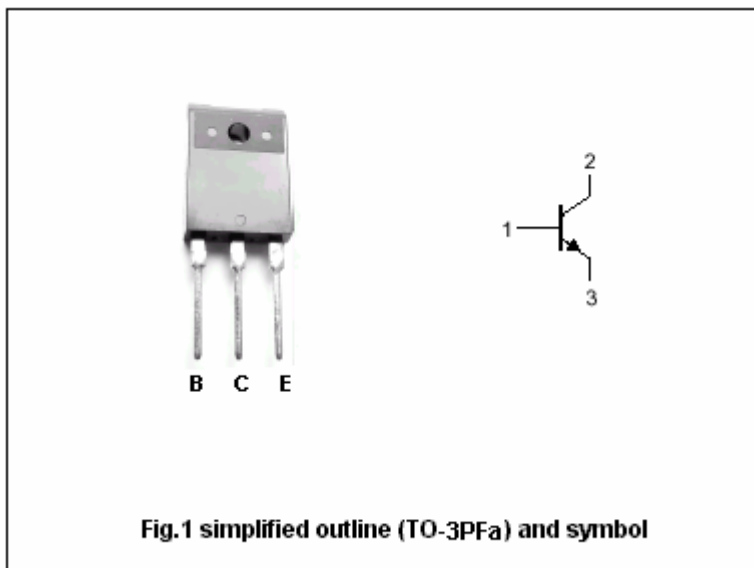
Absolute maximum ratings($T_a=25^\circ\text{C}$)

SYMBOL	PARAMETER	CONDITIONS	VALUE	UNIT
V_{CBO}	Collector-base voltage	Open emitter	1500	V
V_{CEO}	Collector-emitter voltage	Open base	700	V
I_C	Collector current (DC)		8	A
I_{CM}	Collector current (Pulse)		15	A
I_B	Base Collector current (DC)		4	A
I_{BM}	Base current (Pulse)		6	A
P_{tot}	Total power dissipation	$T_C=25^\circ\text{C}$	45	W
T_j	Junction temperature		150	$^\circ\text{C}$
T_{stg}	Storage temperature		-65~150	$^\circ\text{C}$

Silicon NPN Power Transistors

BU2508AF

CHARACTERISTICS

T_j=25°C unless otherwise specified

SYMBOL	PARAMETER	CONDITIONS	MIN	TYP.	MAX	UNIT
V _{CEQ(SUS)}	Collector-emitter sustaining voltage	I _C =100mA ; I _B =0, L=25mH	700			V
V _{(BR)EBO}	Emitter-base breakdown voltage	I _E =1mA ; I _C =0	7.5	13.5		V
V _{CEsat}	Collector-emitter saturation voltage	I _C =4.5A ; I _B =1.1A			1.0	V
V _{BEsat}	Base-emitter saturation voltage	I _C =4.5A ; I _B =1.7 A			1.1	V
I _{CES}	Collector cut-off current	V _{CE} =BV _{CES} ; V _{BE} =0 T _C =125°C			1.0 2.0	mA
I _{EBO}	Emitter cut-off current	V _{EB} =7.5V; I _C =0			1.0	mA
h _{FE-1}	DC current gain	I _C =0.1A ; V _{CE} =5V		13		
h _{FE-2}	DC current gain	I _C =4.5A ; V _{CE} =1V	4	5.5	7	
C _C	Collector capacitance	I _E =0; f=1MHz; V _{CB} =10V		80		pF

Silicon NPN Power Transistors

BU2508AF

PACKAGE OUTLINE

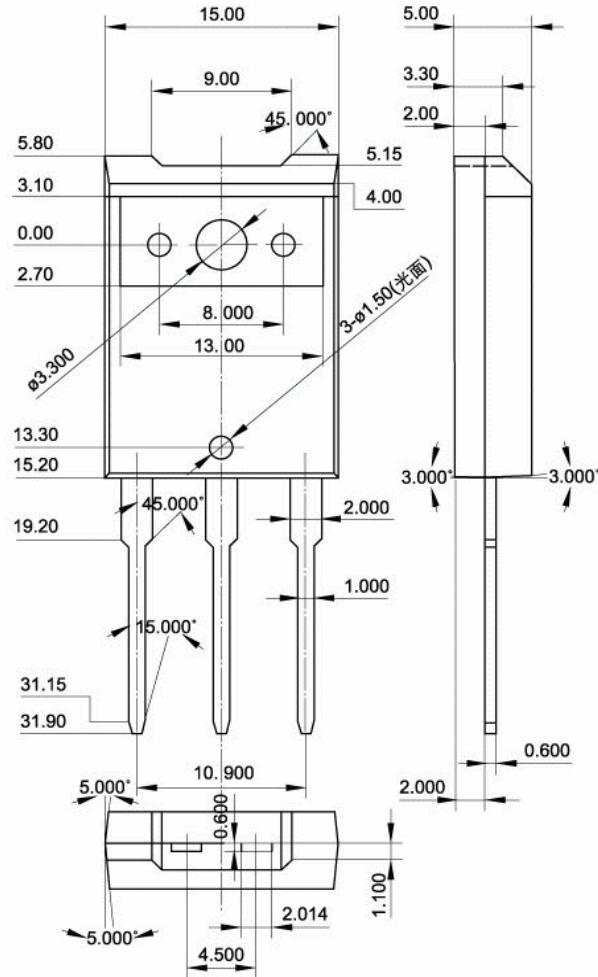

Fig.2 Outline dimensions (unindicated tolerance:±0.30mm)