

# KDB2552(FDB2552)

■ Features

- $r_{DS(ON)} = 32m\Omega$  (Typ.),  $V_{GS} = 10V$ ,  $I_D = 16A$
- $Q_{g(tot)} = 39nC$  (Typ.),  $V_{GS} = 10V$
- Low Miller Charge
- Low QRR Body Diode
- UIS Capability (Single Pulse and Repetitive Pulse)

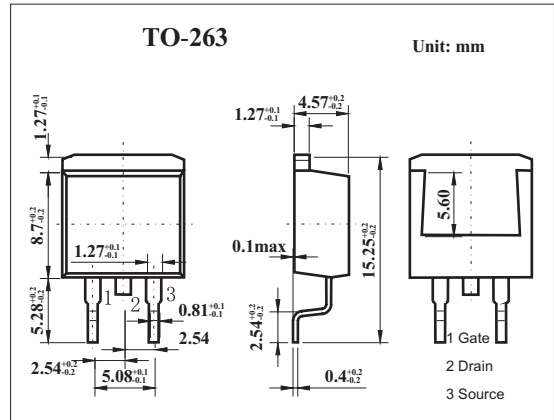
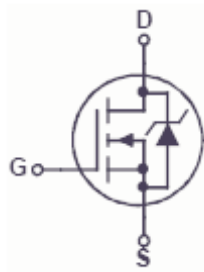

■ Absolute Maximum Ratings  $T_a = 25^\circ C$

Parameter	Symbol	Rating	Unit
Drain to source voltage	$V_{DSS}$	150	V
Gate to source voltage	$V_{GSS}$	$\pm 20$	V
Drain current-Continuous	$I_D$	$T_c=25^\circ C$	37
		$T_A=25^\circ C$	5
Power dissipation	$P_D$	150	W
		Derate above $25^\circ C$	1.0
Thermal Resistance Junction to Ambient	$R_{\theta JA}$	43	$^\circ C/W$
Channel temperature	$T_{ch}$	175	$^\circ C$
Storage temperature	$T_{stg}$	-55 to +175	$^\circ C$

# KDB2552(FDB2552)

■ Electrical Characteristics Ta = 25°C

Parameter	Symbol	Testconditions	Min	Typ	Max	Unit
Drain to source breakdown voltage	V <sub>DSS</sub>	I <sub>D</sub> =250μA, V <sub>GS</sub> =0V	150			V
Drain cut-off current	I <sub>DSS</sub>	V <sub>DS</sub> =120V, V <sub>GS</sub> =0			1	μ A
		V <sub>DS</sub> =120V, V <sub>GS</sub> =0, T <sub>C</sub> =150°C			250	
Gate leakage current	I <sub>GSS</sub>	V <sub>GS</sub> =±20V			±100	nA
Gate threshold voltage	V <sub>GS(th)</sub>	V <sub>DS</sub> = V <sub>GS</sub> , I <sub>D</sub> = 250μA	2.0		4.0	V
Drain to source on-state resistance	R <sub>DS(on)</sub>	V <sub>GS</sub> =10V, I <sub>D</sub> =16A		0.032	0.036	Ω
		V <sub>GS</sub> =6V, I <sub>D</sub> =8A		0.036	0.054	
		V <sub>GS</sub> =10V, I <sub>D</sub> =16A, T <sub>C</sub> =175°C		0.084	0.097	
Input capacitance	C <sub>iss</sub>			2800		pF
Output capacitance	C <sub>oss</sub>	V <sub>DS</sub> =25V, V <sub>GS</sub> =0, f=1MHZ		285		pF
Reverse transfer capacitance	C <sub>rss</sub>			55		pF
Total Gate Charge at 10V	Q <sub>g(TOT)</sub>	V <sub>GS</sub> = 0V to 10V		39	51	nC
Threshold Gate Charge	Q <sub>g(TH)</sub>	V <sub>GS</sub> = 0V to 2V		5.2	6.8	nC
Gate to Source Gate Charge	Q <sub>gs</sub>	V <sub>DS</sub> = 75V,		13.5		nC
Gate Charge Threshold to Plateau	Q <sub>gs2</sub>	I <sub>g</sub> =1.0mA		8.4		nC
Gate to Drain "Miller" Charge	Q <sub>gd</sub>	I <sub>D</sub> = 16A		8.3		nC
Turn-On Time	t <sub>ON</sub>				62	ns
Turn-On Delay Time	t <sub>d(ON)</sub>			12		ns
Rise Time	t <sub>r</sub>	V <sub>DD</sub> = 75V, I <sub>D</sub> = 16A		29		ns
Turn-Off Delay Time	t <sub>d(OFF)</sub>	V <sub>GS</sub> = 10V, R <sub>GS</sub> = 8.2 Ω		36		ns
Fall Time	t <sub>f</sub>			29		ns
Turn-Off Time	t <sub>OFF</sub>				97	ns
Reverse Recovery Time	t <sub>rr</sub>	I <sub>SD</sub> = 16A, di <sub>SD</sub> /dt = 100A/μs			90	ns
Reverse Recovered Charge	Q <sub>Rr</sub>	I <sub>SD</sub> = 16A, di <sub>SD</sub> /dt = 100A/μs			242	nC
Source to Drain Diode Voltage	V <sub>SD</sub>	I <sub>SD</sub> = 16A			1.25	V
		I <sub>SD</sub> = 8A			1.0	V