

REVISIONS			
LTR	DESCRIPTION	DATE	APPROVED
H	REVISED PER ECN AD95009		

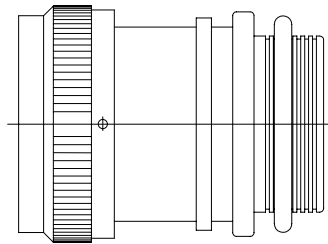

CODE 40 TINEL-LOCK ADAPTER

NOTES:

1. THIS PRODUCT IS DESIGNED TO TERMINATE A BRAIDED CABLE SHIELD AND A HEAT SHRINKABLE LIPPED BOOT TO A CONNECTOR.
2. SEE CH00-0250-008 FOR ORDERING INFORMATION, MODIFICATIONS AND ADDITIONAL DIMENSIONS.
- ③ SEE DRAWING "TR" FOR DETAILS ON TINEL-LOCK RING. RINGS ARE DESIGNED TO BE HEATED ELECTRICALLY. ALL RINGS ARE MARKED WITH THERMOCHROMIC PAINT WHICH CHANGES COLOR WHEN INSTALLATION TEMPERATURE IS REACHED.
4. ADAPTER TO BE PERMANENTLY MARKED WITH CODE IDENT. NO. AND PART NO. LESS RING DESIGNATOR (E.G.: 06090-TXR40AB00-1206). RINGS SHALL BEAR NO MARKING.
- ⑤ FOR LARGER ENTRY SIZES, A 2 PIECE ADAPTER (TYPE II) IS SUPPLIED.
- ⑥ ADAPTER MATES TO MIL-C-38999, SERIES III AND IV, CLASS C, F, K, AND W, D38999/20, /24, /26, /40, /46, /47 CONNECTORS, AND WHEN SO MATED SHALL PROVIDE A WATER-TIGHT SEAL MEETING THE REQUIREMENTS OF MIL-C-85049, PAR. 3.5.7.
- ⑦ THESE DIMENSIONS APPLY IF A SELF-LOCKING COUPLING NUT IS USED. (MOD. CODE "S").
- ⑧ COUPLING NUT SHALL HAVE 3 LOCK WIRE HOLES, 120° APART.

If this document is printed it becomes uncontrolled.  
Check for the latest revision.

SPECIFICATION CONTROL DRAWING

UNLESS OTHERWISE SPECIFIED DIMENSIONS ARE IN INCHES. METRIC DIMENSIONS ARE IN BRACKETS.  DECIMALS .XXX ± — [ mm] .XX ± — [ mm] .X ± — [ mm]  ANGLES .X ± —	DRAW R. RAMIREZ	DATE 03-18-93		Tyco Electronics Corporation 300 Constitution Drive Menlo Park, CA. 94025 U.S.A.		
	CHECKED	DATE				
	APPROVED W. C. GAY	DATE 05-19-93	TITLE TINEL-LOCK™ ADAPTER			
	APPROVED	DATE	CAD NAME \ACAD12\TXR40			
THIRD ANGLE PROJECTION			SIZE A	CODE IDENT. NO. 06090	DWG. NO. TXR40	REV H
			DO NOT SCALE THIS DWG		SHEET 1 OF 3	

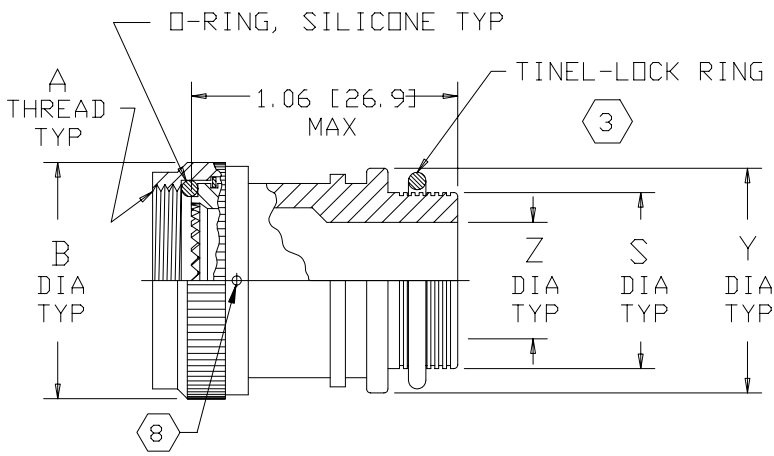

STRAIGHT ADAPTER-TYPE I

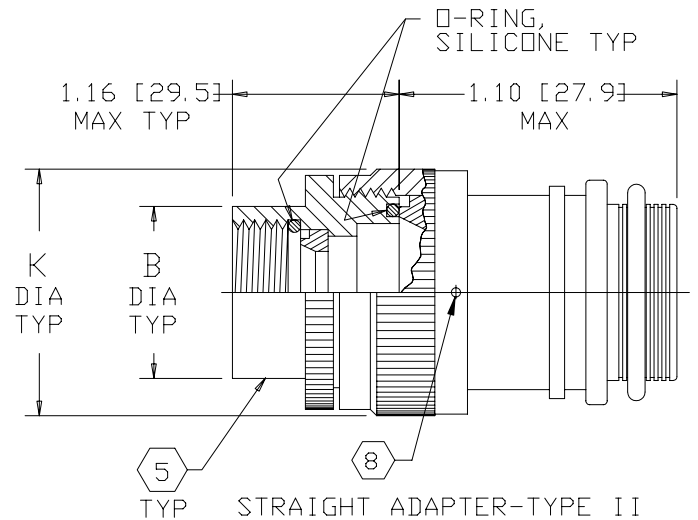

TYP STRAIGHT ADAPTER-TYPE II

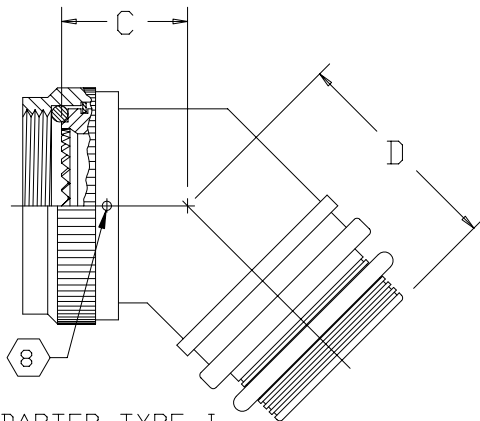

45° ADAPTER-TYPE I

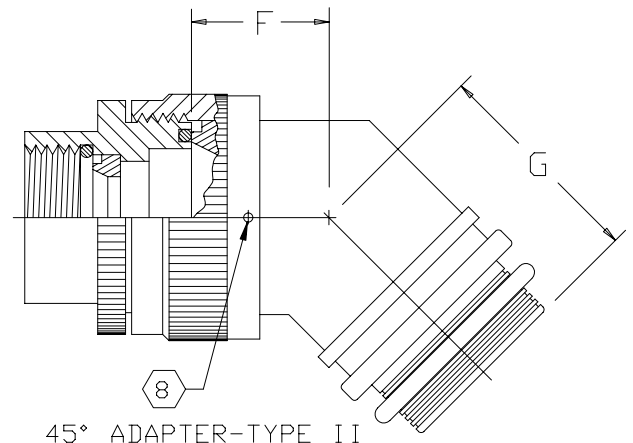

45° ADAPTER-TYPE II

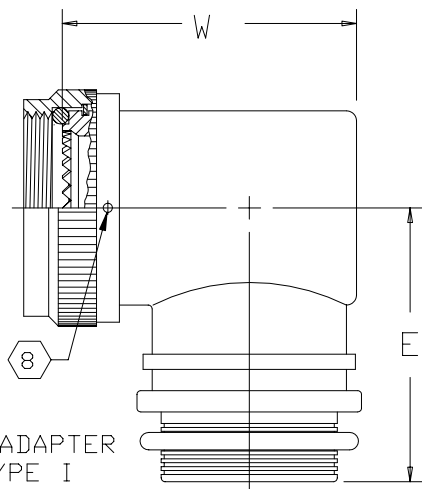

90° ADAPTER TYPE I

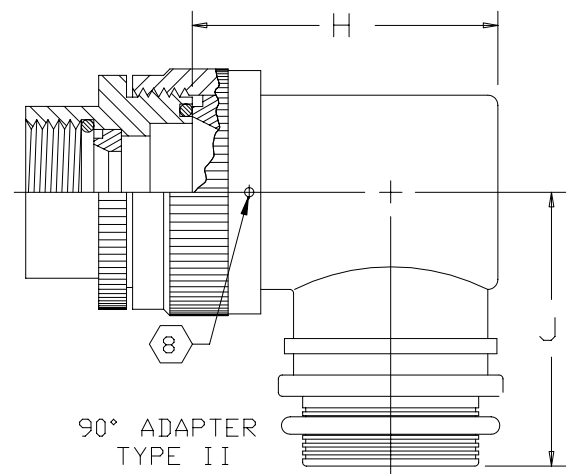

90° ADAPTER TYPE II

If this document is printed it becomes uncontrolled.  
Check for the latest revision.

SIZE	CODE	IDENT. NO.	DWG. NO.	REV
A	06090		TXR40	H
DO NOT SCALE THIS DWG			CAD NAME \ACAD12\TXR40-2	SHEET 2 OF 3

TABLE I



ORDER NO.	SHELL SIZE 		MAX ENTRY SIZE  TYPE I	A METRIC THD CLASS 6H	B DIA MAX	B DIA MAX 	C MAX	D MAX	E MAX
	COM'L	MIL							
08	9	A	04	M12 X 1.0	.750 [19.1]	.969 [24.6]	.82 [20.8]	.89 [22.6]	1.10 [27.9]
10	11	B	07	M15 X 1.0	.850 [21.6]	1.063 [27.0]	.84 [21.3]	.92 [23.4]	1.20 [30.5]
12	13	C	08	M18 X 1.0	1.000 [25.4]	1.219 [31.0]	.87 [22.1]	.95 [24.1]	1.26 [32.0]
14	15	D	10	M22 X 1.0	1.150 [29.2]	1.406 [35.7]	.89 [22.6]	.95 [24.1]	1.34 [34.0]
16	17	E	12	M25 X 1.0	1.250 [31.8]	1.469 [37.3]	.92 [23.4]	.98 [24.9]	1.40 [35.6]
18	19	F	14	M28 X 1.0	1.400 [35.6]	1.594 [40.5]	.95 [24.1]	1.01 [25.7]	1.45 [36.8]
20	21	G	16	M31 X 1.0	1.500 [38.1]	1.750 [44.5]	.97 [24.6]	1.04 [26.4]	1.51 [38.4]
22	23	H	18	M34 X 1.0	1.650 [41.9]	1.844 [46.8]	1.00 [25.4]	1.07 [27.2]	1.57 [39.9]
24	25	J	20	M37 X 1.0	1.750 [44.5]	2.031 [51.6]	1.02 [25.9]	1.07 [27.2]	1.67 [42.4]

TABLE II

ENTRY SIZE	Z +.010 -.020	S DIA	Y ±.015 [±0.38]	W MAX	F MAX	G MAX	H MAX	J MAX	K MAX
04	.250 [6.35]	.376 [9.56] .370 [9.39]	.550 [13.97]	1.23 [31.2]	N/A	N/A	N/A	N/A	N/A
05	.312 [7.92]	.438 [11.13] .432 [10.97]	.612 [15.54]	1.29 [32.8]	.77 [19.6]	.93 [23.6]	1.19 [30.2]	1.16 [29.5]	.80 [20.3]
06	.375 [9.52]	.501 [12.73] .495 [12.57]	.675 [17.14]	1.35 [34.3]	.77 [19.6]	.93 [23.6]	1.19 [30.2]	1.16 [29.5]	.80 [20.3]
07	.437 [11.09]	.563 [14.31] .556 [14.12]	.737 [18.71]	1.42 [36.1]	.80 [20.3]	.95 [24.1]	1.38 [35.1]	1.22 [31.0]	.92 [23.4]
08	.500 [12.70]	.626 [15.91] .619 [15.72]	.800 [20.32]	1.48 [37.6]	.80 [20.3]	.95 [24.1]	1.38 [35.1]	1.22 [31.0]	.92 [23.4]
10	.625 [15.87]	.752 [19.11] .742 [18.84]	.925 [23.49]	1.60 [40.6]	.84 [21.3]	1.00 [25.4]	1.51 [38.4]	1.35 [34.3]	1.18 [30.0]
12	.750 [19.05]	.877 [22.28] .867 [22.02]	1.050 [26.67]	1.73 [43.9]	.86 [21.8]	1.01 [25.7]	1.63 [41.4]	1.40 [35.6]	1.35 [34.3]
14	.875 [22.23]	1.002 [25.46] .991 [25.17]	1.175 [29.84]	1.85 [47.0]	.88 [22.4]	1.04 [26.4]	1.78 [45.2]	1.46 [37.1]	1.41 [35.8]
16	1.000 [25.40]	1.127 [28.63] 1.116 [28.34]	1.300 [33.02]	2.00 [50.8]	.91 [23.1]	1.06 [26.9]	1.88 [47.8]	1.53 [38.9]	1.60 [40.6]
18	1.125 [28.57]	1.252 [31.81] 1.241 [31.52]	1.425 [36.19]	2.13 [54.1]	.93 [23.6]	1.09 [27.7]	2.01 [51.1]	1.59 [40.4]	1.66 [42.2]
20	1.250 [31.75]	1.377 [34.98] 1.366 [34.69]	1.550 [39.37]	2.25 [57.2]	.98 [24.9]	1.13 [28.7]	2.13 [54.1]	1.78 [45.2]	2.04 [51.8]
22	1.375 [34.93]	1.502 [38.15] 1.488 [37.79]	1.675 [42.55]	N/A	1.03 [26.2]	1.38 [35.1]	2.29 [58.2]	1.85 [47.0]	2.23 [56.6]
24	1.500 [38.10]	1.627 [41.33] 1.613 [40.97]	1.800 [45.72]	N/A	1.08 [27.4]	1.44 [36.6]	2.42 [61.5]	1.92 [48.8]	2.23 [56.6]

If this document is printed it becomes uncontrolled.  
Check for the latest revision.

SIZE A	CODE IDENT. NO. 06090	DWG. NO. TXR40	REV H
DO NOT SCALE THIS DWG		CAD NAME \\ACAD\TXR40-3	SHEET 3 OF 3