

DIESEL GENERATOR SET

DP40D6S

40 kWe / 60 Hz / Prime
208 - 600V

(Reference DS40D6S for Standby Rating Technical Data)



SYSTEM RATINGS

Prime	DP40D6SGT	DP40D6SPT	DP40D6SJT	DP40D6SVT	DP40D6SRT	DP40D6SNT
Voltage (L-L)	240V**	208**	240V**	380V**	480V**	600V**
Phase	1	3	3	3	3	3
PF	1.0	0.8	0.8	0.8	0.8	0.8
Hz	60	60	60	60	60	60
kW	40	40	40	40	40	40
kVA	40	50	50	50	50	50
Amps	167	139	120	76	60	48
skVA@30%						
Voltage Dip	63	128	128	128	172	92
Generator Model	361CSL1601	361CSL1601	361CSL1601	361CSL1601	361CSL1601	361PSL1632
Temp Rise	105 °C/40 °C	105 °C/40 °C	105 °C/40 °C	105 °C/40 °C	105 °C/40 °C	105 °C/40 °C
Connection	12 LEAD DOUBLE DELTA	12 LEAD LOW WYE	12 LEAD HI DELTA	12 LEAD HI WYE	12 LEAD HI WYE	4 LEAD WYE

** UL 2200 Offered

CERTIFICATIONS AND STANDARDS

// Emissions – EPA Tier 3 Certified

// Generator set is designed and manufactured in facilities certified to standards ISO 9001:2008 and ISO 14001:2004

// UL 2200 / CSA – Optional
- UL 2200 Listed
- CSA Certified

// Performance Assurance Certification (PAC)

- Generator Set Tested to ISO 8528-5 for Transient Response
- Verified product design, quality and performance integrity
- All engine systems are prototype and factory tested

// Power Rating

- Accepts Rated Load in One Step Per NFPA 110

STANDARD FEATURES*

- // MTU Onsite Energy is a single source supplier
 - // Global Product Support
 - // 2 Year Standard Warranty
 - // 4045TF280 Diesel Engine
 - 4.5 Liter Displacement
 - Mechanical Injection Pump
 - 4-Cycle
 - // Engine-generator resilient mounted
 - // Complete Range of Accessories
- // Generator
 - Brushless, Rotating Field Generator
 - 2/3 Pitch Windings
 - 300% Short Circuit Capability with Optional PMG
 - // Digital Control Panel(s)
 - UL Recognized, CSA Certified, NFPA 110
 - Complete System Metering
 - LCD Display
 - // Cooling System
 - Integral Set-Mounted
 - Engine Driven Fan

STANDARD EQUIPMENT*

// Engine

Air Cleaner
 Oil Pump
 Oil Drain Extension & S/O Valve
 Full Flow Oil Filter
 Fuel Filter with Water Separator
 Jacket Water Pump
 Thermostat
 Blower Fan & Fan Drive
 Radiator - Unit Mounted
 Electric Starting Motor - 12V
 Governor - Mechanical Droop
 Base - Formed Steel
 SAE Flywheel & Bell Housing
 Charging Alternator - 12V
 Battery Box & Cables
 Flexible Fuel Connectors
 Flexible Exhaust Connection
 EPA Certified Engine

// Generator

NEMA MG1, IEEE and ANSI standards compliance for temperature rise and motor starting
 Self-Ventilated and Drip-Proof
 Superior Voltage Waveform
 Solid State, Volts-per-Hertz Regulator
 $\pm 1\%$ Voltage Regulation No Load to Full Load
 Brushless Alternator with Brushless Pilot Exciter
 4 Pole, Rotating Field

105 °C Maximum Prime Temperature Rise
 1 Bearing, Sealed
 Flexible Coupling
 Full Amortisseur Windings
 125% Rotor Balancing
 3-Phase Voltage Sensing
 100% of Rated Load - One Step
 5% Maximum Total Harmonic Distortion

// Digital Control Panel(s)

Digital Metering
 Engine Parameters
 Generator Protection Functions
 Engine Protection
 SAE J1939 Engine ECU Communications
 Windows®-Based Software
 Multilingual Capability
 Remote Communications to RDP-110 Remote Annunciator
 Programmable Contact Inputs
 Programmable Contact Outputs
 UL Recognized, CSA Certified, CE Approved
 Event Recording
 IP 54 Front Panel Rating with Integrated Gasket
 NFPA 110 Compatible

* Represents standard product only. Consult Factory/MTU Onsite Energy Distributor for additional configurations.

APPLICATION DATA

// Engine

Manufacturer	John Deere
Model	4045TF280
Type	4-Cycle
Arrangement	4-Inline
Displacement: L (in ³)	4.5 (275)
Bore: cm (in)	10.6 (4.19)
Stroke: cm (in)	12.7 (5.0)
Compression Ratio	19.0:1
Rated RPM	1,800
Engine Governor	Mechanical Droop
Maximum Power: kWm (bhp)	57 (76)
Speed Regulation	±0.50%
Air Cleaner	Dry

// Liquid Capacity (Lubrication)

Total Oil System: L (gal)	13 (3.4)
Engine Jacket Water Capacity: L (gal)	8.5 (2.3)
System Coolant Capacity: L (gal)	18.9 (5)

// Electrical

Electric Volts DC	12
Cold Cranking Amps Under -17.8 °C (0 °F)	925

// Fuel System

Fuel Supply Connection Size	3/8" NPT
Fuel Return Connection Size	3/8" NPT
Maximum Fuel Lift: m (ft)	1.8 (6)
Recommended Fuel	Diesel #2
Total Fuel Flow: L/hr (gal/hr)	56.4 (14.9)

// Fuel Consumption

	PRIME
At 100% of Power Rating: L/hr (gal/hr)	15.9 (4.2)
At 75% of Power Rating: L/hr (gal/hr)	12.5 (3.3)
At 50% of Power Rating: L/hr (gal/hr)	9.1 (2.4)

// Cooling - Radiator System

	PRIME
Ambient Capacity of Radiator: °C (°F)	50 (122)
Maximum Allowable Static	
Pressure on Rad. Exhaust: kPa (in. H ₂ O)	0.12 (0.5)
Water Pump Capacity: L/min (gpm)	144 (38)
Heat Rejection to Coolant: kW (BTUM)	33 (1,878)
Heat Radiated to Ambient: kW (BTUM)	5.8 (327)
Fan Power: kW (hp)	1.6 (2.2)

// Air Requirements

	PRIME
Aspirating: *m ³ /min (SCFM)	5.1 (180)
Air Flow Required for Rad.	
Cooled Unit: *m ³ /min (SCFM)	117 (4,088)
Remote Cooled Applications;	
Air Flow Required for Dissipation	
of Radiated Gen-set Heat for a	
Max of 25 °F Rise: *m ³ /min (SCFM)	21 (738)

* Air density = 1.184 kg/m³ (0.0739 lbm/ft³)

// Exhaust System

	PRIME
Gas Temp. (Stack): °C (°F)	551 (1,024)
Gas Volume at Stack	
Temp: m ³ /min (CFM)	18.3 (645)
Maximum Allowable	
Back Pressure: kPa (in. H ₂ O)	7.5 (30)
Minimum Allowable	
Back Pressure: kPa (in. H ₂ O)	N/A

WEIGHTS AND DIMENSIONS

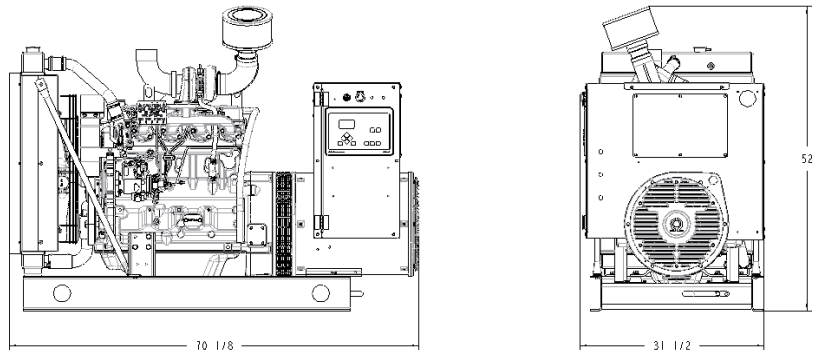

Drawing above for illustration purposes only, based on standard open power 480 volt generator set. Lengths may vary with other voltages. Do not use for installation design. See website for unit specific template drawings.

System	Dimensions (L x W x H)	Weight (dry/less tank)
Open Power Unit (OPU)	1,781 x 800 x 1,321 mm (70.13 x 31.50 x 52 in)	872 kg (1,920 lb)

Weights and dimensions are based on open power units and are estimates only. Consult the factory for accurate weights and dimensions for your specific generator set.

SOUND DATA

Unit Type	Prime Full Load
Level 0: Open Power Unit dB(A)	80.2

Sound data is provided at 7 m (23 ft). Generator set tested in accordance with ISO 8528-10 and with infinite exhaust.

EMISSIONS DATA

NO_x	HC	CO	PM
3.1	0.22	0.8	0.18

All units are in g/hp-hr and are EPA D2 cycle values.

Emission levels of the engine may vary as a function of ambient temperature, barometric pressure, humidity, fuel type and quality, installation parameters, measuring instrumentation, etc. The data provided are laboratory results from one engine representing this rating. The data was obtained under controlled environmental conditions with calibrated instrumentation traceable to the United States National Bureau of Standards and in compliance with US EPA regulations found within 40 CFR Part 89. The weighted cycle value from each engine is guaranteed to be below the US EPA Standards at the US EPA defined conditions.

RATING DEFINITIONS AND CONDITIONS

- // Prime power ratings apply to installations where utility power is unavailable or unreliable. At varying load, the number of generator set operating hours is unlimited. A 10% overload capacity is available for one hour in twelve. Ratings are in accordance with ISO 8528-1, overload power in accordance with ISO 3046-1, BS 5514, AS 2789, and DIN 6271.
- // Deration Factor:
 - Altitude:** Consult your local MTU Onsite Energy Power Generation Distributor for altitude derations.
 - Temperature:** Consult your local MTU Onsite Energy Power Generation Distributor for temperature derations.

Materials and specifications subject to change without notice.

C/F = Consult Factory/MTU Onsite Energy Distributor